

Electronics & Communication Engineering

ELECTRONIC DEVICES

Text Book:

Theory with worked out Examples and Practice Questions

Chapter

1

Basics of Semiconductors

(Solutions for Text Book Practice Questions)

01. Ans: (a)

$$\text{Sol: } N_D = 5 \times 10^{22} \times \frac{1}{10^9} \text{ cm}^{-3}$$

$$= 5 \times 10^{13} \text{ cm}^{-3}$$

According to mass action law

$$np = n_i^2$$

$$n_n p_n = n_i^2$$

$$N_D p_n = n_i^2 \quad (\because n_n \approx N_D)$$

$$p_n = \frac{n_i^2}{N_D}$$

$$p_n = \frac{(1.5 \times 10^{10})^2}{5 \times 10^{13}}$$

$$= 4.5 \times 10^6 \text{ cm}^{-3}$$

02. Ans: (b)

Sol: According to law of mass action $n.p = n_i^2$

Where n_i = intrinsic carrier concentration.

N_D = doping concentration for a n-type material.

Majority carrier concentration

$$n \approx N_D$$

$$p = \frac{n_i^2}{N_D}$$

$$p \propto \frac{1}{N_D}$$

03. Ans: (b)

Sol: $V = 5V$

$L = 100 \text{ mm}$

$\mu_n = 3800 \text{ cm}^2/\text{V-sec}$

$\mu_p = 1800 \text{ cm}^2/\text{V-sec}$

$V_{dn} = \mu_n E$

$$= 3800 \times \frac{V}{L}$$

$$= 3800 \times \frac{5}{100 \times 10^{-1}}$$

$$= 1900 \text{ cm/sec}$$

04. Ans: (d)

Sol: For the n-type semiconductor with

$n = N_D$ and $p = n_i^2 / N_D$, the hole

concentration will fall below the intrinsic value because some of the holes recombine with electrons.

05. Ans: (c)

Sol: $N_A = \frac{10^{15}}{1.6} \text{ acceptor/cm}^3$

$\mu_n = 4000 \text{ cm}^2/\text{V-sec}$

$\mu_p = 2000 \text{ cm}^2/\text{V-sec}$

$\sigma_p = p q \mu_p$

$= N_A q \mu_p$ (\because 100% doping efficiency)

$$= \frac{10^{15}}{1.6} \times 1.6 \times 10^{-19} \times 2000$$

$$= 0.2 \text{ mho/cm}$$

06. Ans: (d)

Sol: According to mass action law.

$$np = n_i^2$$

$$n_n p_n = n_i^2$$

$$n_p p_p = n_i^2$$

$$n_p N_A \approx n_i^2$$

$$N_D p_n \approx n_i^2$$

07. Ans: (a)

Sol: $R_H = 3.6 \times 10^{-4} \text{ m}^3/\text{c}$

$$\rho = 9 \times 10^{-3} \Omega\text{-m}$$

Let us consider n-type semiconductor

$$R_H = \frac{1}{nq}$$

$$n = \frac{1}{qR_H} = \frac{1}{1.6 \times 10^{-19} \times 3.6 \times 10^{-4}}$$

$$= 1.736 \times 10^{22} \text{ m}^{-3}$$

08. Ans: (b)

Sol: At equilibrium

No. of e^- density = No. of hole density

\therefore given e^- density is $n(x_1) = 10 n(x_2)$

$\Rightarrow n(x_1)$ is majority

$\Rightarrow n(x_2)$ is minority

$\therefore p(x_2) = 10p(x_1)$

09. Ans: (b)

Sol: $\rho_p = 3 \times 10^3 \Omega - m$

$$\mu_p = 0.12 \text{ m}^2/\text{V-sec}$$

$$V_H = 60 \text{ mV}$$

$$\rho_p = \frac{1}{\sigma_p}$$

$$3 \times 10^3 = \frac{1}{pq\mu_p}$$

$$p = \frac{1}{3 \times 10^3 \times 1.6 \times 10^{-19} \times 0.12}$$

$$p = 1.736 \times 10^{16} \text{ m}^{-3}$$

$$R_H = \frac{1}{pq} = \frac{1}{1.736 \times 10^{16} \times 1.6 \times 10^{-19}}$$

$$= 360 \text{ m}^3/\text{C}$$

10. Ans: (b)

Sol: $J_{\text{drift}} = n\mu_n qE + p\mu_p qE$

$$J_{\text{drift}} = [(n \cdot q)\mu_n + (p \cdot q)\mu_p]E$$

$$J_{\text{drift}} = [\rho_n \mu_n + \rho_p \mu_p]$$

$$J \propto 'p'$$



Charge concentration

11. Ans: (c)

Sol: $D_n = 20 \text{ cm}^2/\text{s}$

$$\mu_n = 1600 \text{ cm}^2/\text{V-s}$$

$$\frac{D}{\mu} = \frac{kT}{q} = V_T$$

$$\Rightarrow V_T = \frac{20}{1600} = 12.5 \text{ mV}$$

12. Ans: (d)

Sol: Conductivity of a semiconductor,

$$\sigma = (n\mu_n + p\mu_p)q$$

Where, $\mu_n \rightarrow$ mobility of electrons

$\mu_p \rightarrow$ mobility of holes

$n \rightarrow$ electron concentration

$p \rightarrow$ hole concentration

$q \rightarrow$ electron charge

13. Ans: (c)

Sol: $N_A = 2.29 \times 10^{16}$

$$E_{F_i} - E_{F_p} = kT \ln \left(\frac{N_A}{n_i} \right)$$

$$= 0.02586 \ln \left(\frac{2.29 \times 10^{16}}{1.5 \times 10^{10}} \right)$$

$$= 0.3682 \text{ eV}$$

$$\approx 0.37 \text{ eV}$$

14. Ans: (b)

Sol: Given,

2 wires $\therefore W_1$ & W_2

$d_2 = 2d_1$ where $d =$ diameter of wire

$L_2 = 4L_1$ where $L =$ length of wire

Relation between resistances of

W_1 & W_2

$$R = \frac{\rho L}{A} = \frac{\rho L}{\pi r^2} \quad r = \frac{d}{2}$$

$$R = \frac{\rho L}{\pi \frac{d^2}{4}} = \frac{4\rho L}{\pi d^2} \quad R \propto \frac{L}{d^2}$$

$$\frac{R_1}{R_2} = \frac{\frac{L_1}{d_1^2}}{\frac{L_2}{d_2^2}} = \frac{L_1}{d_1^2} \times \frac{d_2^2}{L_2} = \frac{L_1}{d_1^2} \times \frac{(2d_1)^2}{4L_2}$$

$$\Rightarrow \frac{R_1}{R_2} = 1 \quad \therefore R_1 = R_2$$

15. Ans: (c)

Sol: Hall voltage, V_H is inversely proportional to carrier concentration

$$\Rightarrow \frac{V_{H2}}{V_{H1}} = \frac{P_1}{P_2} = \frac{P_1}{2P_1}$$

$$\therefore V_{H2} = \frac{1}{2} V_{H1}$$

16. Ans: (b)

Sol: $\frac{D}{\mu} = \frac{kT}{q} = V_T$

$$\therefore D = \frac{0.36 \times 1.38 \times 10^{-23} \times 300}{1.6 \times 10^{-19}}$$

$$= 9.315 \times 10^{-3} \text{ m}^2/\text{sec}$$

Diffusion length, $L = \sqrt{D\tau}$

$$= \sqrt{9.315 \times 10^{-3} \times 340 \times 10^{-6}}$$

$$= 1.77 \times 10^{-3} \text{ m}$$

17. Ans: (a)

Sol: In intrinsic semiconductor,
Number of electron = Number of holes

18. Ans: (a, b, c & d)

Sol: (a) Continuity equation for holes is given by

$$\frac{\partial p}{\partial t} = -\frac{1}{q} \frac{\partial J_p}{\partial x} + G^1 - \frac{\delta p}{\tau}$$

Similarity continuity equation for electrons is

$$\frac{\partial n}{\partial t} = \frac{1}{q} \frac{\partial J_n}{\partial x} + G^1 - \frac{\delta n}{\tau}$$

These equations describe the rate of change of minority carries with time.

(b) Einstein's equation

$$\frac{D_n}{\mu_n} = V_T \text{ and } \frac{D_p}{\mu_p} = V_T \rightarrow \text{Diffusion}$$

constant and mobility are related

(c) Poisson's equation is given by

$$\frac{\partial^2 v}{\partial x^2} = \frac{-\rho}{\epsilon} \text{ and } E = \frac{-\partial v}{\partial x}$$

charge density and electric field are related

(d) Diffusion equation

$$J_{p_{Diff}} = -qD_p \frac{dp}{dx} \text{ and } J_{n_{Diff}} = qD_n \frac{dn}{dx}$$

Rate of change of carrier concentration in the space.

19. Ans: (a)

Sol: In P-type, as doping increases hole concentration p increases. According to mass action law $n_p = \frac{n_i^2}{P_p} \Rightarrow$ electron concentration decreases.

20. Ans: (b)

Sol: In intrinsic semiconductor, electron hole pairs are generated due to external energy \Rightarrow true. electron mobility is 2 to 3 times more than hole mobility \Rightarrow true. Both the statements are true but statement II is not a correct explanation of statement I.

21. Ans: (a)

Sol: Both Statement (I) and Statement (II) are true and Statement (II) is the correct explanation of Statement (I).

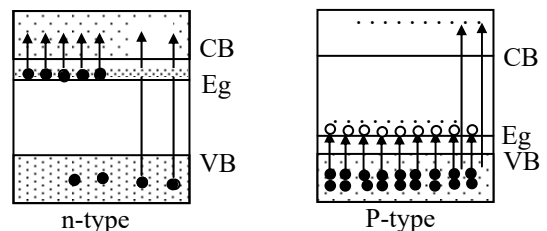

Chapter 2 PN Junction Diode

01. Ans: (c)

Sol:

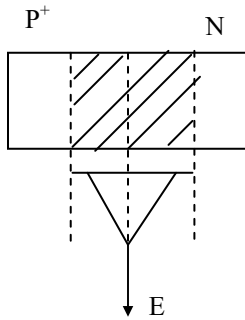

In P⁺, '+' indicates heavily region and 'N' indicates lightly doped region.

02. Ans: (a)

$$\text{Sol: } w = \sqrt{\frac{2\epsilon V_0}{q} \left[\frac{1}{N_D} + \frac{1}{N_A} \right]}$$

$$\frac{w_2}{w_1} = \sqrt{\frac{V_0 - V_{R2}}{V_0 - V_{R1}}}$$

$$\frac{w_2}{2\mu\text{m}} = \sqrt{\frac{0.8 - (-7.2)}{0.8 - (-1.2)}}$$

$$w_2 = 4 \mu\text{m}.$$

03. Ans: (a)

$$\text{Sol: } I = \left[\frac{AeD_p p_{n0}}{L_p} + \frac{AeD_n n_{p0}}{L_n} \right]$$

$$\Rightarrow I = \frac{AeD_p p_{n0}}{L_p}$$

$$\frac{I}{A} = \frac{eD_p p_{n0}}{L_p}$$

$$= \frac{1.602 \times 10^{-19} \times 12 \times 10^{12}}{1 \times 10^{-3}}$$

$$= 1.92 \text{ mA/cm}^2$$

04. Ans: (c)

$$\text{Sol: } 1 \text{ mA} = I_{GO} (e^{V_G/\eta V_T} - 1) = I_{SO} (e^{V_S/\eta V_T} - 1)$$

$$\frac{I_{GO}}{I_{SO}} = \frac{e^{0.718/(2 \times 0.026)}}{e^{0.1435/(1 \times 0.026)}} \cong 4000 = 4 \times 10^3$$

05. Ans: (c)

Sol: In a PN Junction diode the dynamic

$$\text{conductance } g_m = \frac{\Delta I}{\Delta V}, g_m = \frac{I_C}{V_T}$$

$$\text{i.e. } g_m \propto I_C$$

06. Ans: (d)

Sol: i - v characteristic of the diode

$$i = \frac{v - 0.7}{500} \text{ A, } v \geq 0.7 \text{ V} \quad \dots (1)$$

From the given circuit, Loop equation :

$$v = 10 - 1000 i, v \geq 0.7 \text{ V} \quad \dots (2)$$

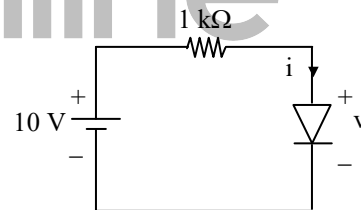

Eliminating 'v' from (1) and (2) :

$$i = \frac{10 - 1000 i - 0.7}{500} = \frac{9.3}{500} - 2i$$

$$3i = \frac{9.3}{500}, i = \frac{3.1}{500} \text{ A} = 6.2 \text{ mA}$$

07. Ans: (b)

Sol: Given,

$$V_\gamma = 0.498 \text{ V}$$

$$V_T = 2 \text{ mV}$$

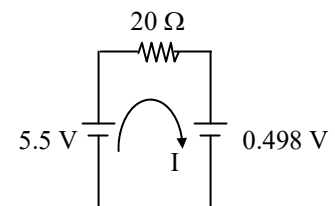

$$\begin{aligned} \therefore I &= \frac{5.5 - 0.498}{20} \\ &= 0.2501 \Rightarrow 250 \text{ mA} \end{aligned}$$

08. Ans: (a)

Sol: Given $I_2^1 = I_1 \times 32$

Given $T_1 = 40^\circ\text{C}$ $T_2 = ?$

$$I_2^1 = I_1 \left(2^{\frac{T_2 - T_1}{10}} \right)$$

$$I_1 \times 32 = I_1 \left(2^{\frac{T_2 - T_1}{10}} \right)$$

$$2^5 = 2^{\frac{T_2 - T_1}{10}}$$

$$\Rightarrow \frac{T_2 - T_1}{10} = 5$$

$$T_2 - T_1 = 50$$

$$T_2 = 90^\circ\text{C}$$

$$T_2 = 50 + T_1$$

09. Ans: (b)

Sol: For either Si (or) Ge

$$\frac{dV}{dT} \cong -2.5 \text{ mV}/^\circ\text{C}$$

To maintain constant current

$$\frac{(V_2 - 700\text{mV})}{(40 - 20)} \frac{V}{^\circ\text{C}} = -2.5 \times 10^{-3} \frac{V}{^\circ\text{C}}$$

$$\rightarrow V_2 = 650 \text{ mV}$$

10. Ans: (b)

$$\begin{aligned} \text{Sol: } C &= \frac{\epsilon_0 \epsilon_r A}{d} \Rightarrow \frac{C}{A} = \frac{\epsilon_0 \epsilon_r}{d} \\ &= \frac{11.7 \times 8.85 \times 10^{-12}}{10 \times 10^{-6}} \\ &= 10.36 \text{ } \mu\text{F}/\text{m}^2 \end{aligned}$$

11. Ans: (a, b & c)

Sol: $V_b = E_{Fn} - E_{Fi} + E_{Fi} - E_{FP}$

$$= \frac{KT}{q} \ln \left(\frac{N_D}{n_i} \right) + \frac{KT}{q} \ln \left(\frac{N_A}{n_i} \right)$$

$$V_b = \frac{KT}{q} \ln \left[\frac{N_A N_D}{n_i^2} \right]$$

$$N_A \text{ \& } N_D \uparrow \rightarrow \frac{KT}{q} \ln \left[\frac{N_A N_D}{n_i^2} \right] \uparrow \rightarrow V_b \uparrow$$

Since 1995

ACE

Chapter 3

Zener Diode

01. Ans: (d)

Sol:

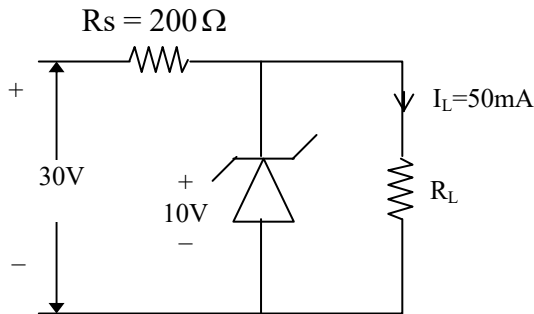

$$V_s = 30 - 10 = 20V$$

$$\begin{aligned} \text{Power dissipation} &= \frac{V_s^2}{R_s} \\ &= \frac{20^2}{200} \\ &= 2 \text{ W} \end{aligned}$$

02. Ans: (c)

Sol: Power rating of Zener diode = 5 mW

$$I_z V_z = 5 \times 10^{-3}$$

$$I_z = \frac{5 \times 10^{-3}}{5} = 1 \text{ mA}$$

: Current flows through the circuit is = 1 mA

$$R_z = \frac{10 - 5}{1 \text{ m}} = 5 \text{ k}\Omega$$

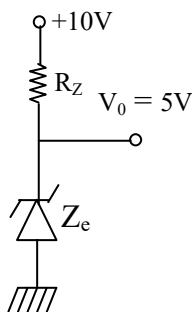

03. Ans: (b)

Sol:

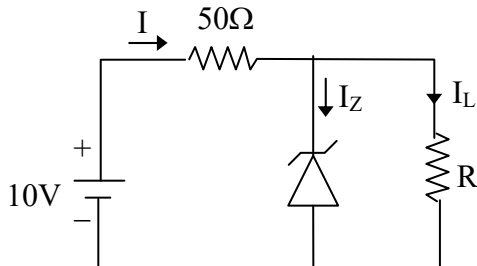

Given that, $V_z = 6V$

$$I_{z \min} = 5 \text{ mA}$$

$$R_{\min} \Rightarrow I_{L \max}$$

$$I = \frac{10 - 6}{50} = \frac{4}{50} = 80 \text{ mA}$$

$$I = I_{z \min} + I_{L \max}$$

$$I_{L \max} = 75 \text{ mA}$$

$$R_{L \min} = \frac{V_z}{I_{L \max}} = \frac{6}{75 \times 10^{-3}} = 80 \Omega$$

04. Ans: (b)

Sol: In -ve cycle of i/p diode forward biased, so replace by short circuit, so o/p = i/p with -12V in o/p only option 'b' exists, so using method of elimination answer is b.

05. Ans: (d)

Sol: Given circuit,

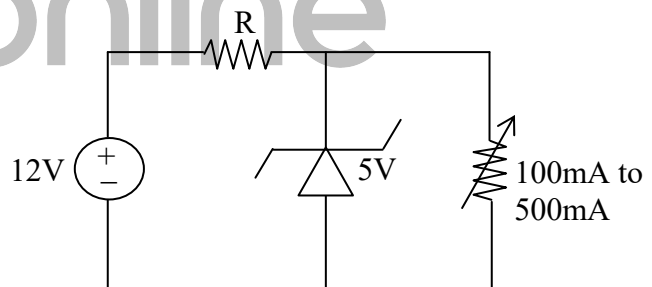

Given, source voltage

$$V_s = 12V$$

$$I_{L \min} = 100 \text{ mA}$$

$$I_{L \max} = 500 \text{ mA}$$

$$V_z = 5V$$

$$I_{z \min} = 0A$$

$$\therefore R = \frac{V_s - V_z}{I_{z \min} + I_{L \max}}$$

$$R = \frac{12 - 5}{500 \text{ mA}}$$

$$R = \frac{7 \times 10^3}{500}$$

$$R = \frac{70}{5} \Omega \quad R = 14 \Omega$$

06. Ans: (c)

Sol: Given circuit,

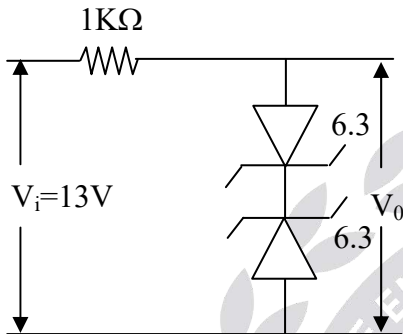

$$V_0 = 0.6 + 6.3 = 6.9 \text{ V}$$

07. Ans: (a)

Sol: The ideal characteristic of a stabilizer is constant output voltage with low internal resistance.

08. Ans: (a)

Sol:

- In PN junction diode break down depends on doping. As doping increases breakdown voltage decreases.
- In Zener diode breakdown is less than 6 V.
- It has Negative Temperature coefficient (operate in R. B)
- Avalanche diode breakdown greater than 6 V.

09. Ans: (b)

Sol: 'A' is correct and 'R' is correct but 'R' is **Not** the correct explanation of 'A' because DC voltage stabilizer circuit can be implemented by using other components like Op-Amp also. There is no need that only Zener diode to be used.

Since 1995

ACE

Chapter 4 Special Purpose Diodes

01. Ans: (a)

Sol: Tunnel diode

It is highly doped S.C ($1 : 10^3$)

It is an abrupt junction (step) with both sides heavily doped made up of Ge (or) GaAs .

It carries both majority and minority currents.

It can be used as oscillator

Operate in Negative Resistance region

Operate as fast switching device .

02. Ans: (c)

Sol: The values of voltage (V_D) across a tunnel-diode corresponding to peak and valley currents are V_P and V_V respectively. The range of tunnel-diode voltage V_D for which the slope of its $I-V_D$ characteristics is negative would be $V_P \leq V_D < V_V$.

03. Ans: (c)

Sol: Schottky diode is made of metal and semiconductor to decrease the switching times, hence it can be used for high frequency applications.

04. Ans: (a)

Sol:

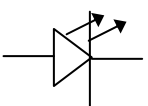
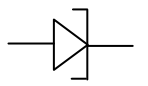
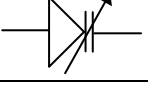
Symbol	Circuit name	Applications
	LED	Direct Band gap
	Tunnel diode	Fast Switching circuits
	Varactor diode	Electronic Tuning

05. Ans: (a)

Sol: The tunnel diode has a region in its voltage current characteristics where the current decreases with increased forward voltage known as its negative resistance region. This characteristic makes the tunnel diode useful in oscillators and as a microwave amplifier.

Chapter 5 Bipolar Junction Transistor

01. Ans: (b)

Sol: $\alpha = \beta/(1+\beta) = 0.9803$
 $\alpha = \beta^* \gamma^*$
 $\rightarrow \beta^* = 0.9803/0.995$
 $= 0.9852$

02. Ans: (d)

Sol: $I_C = 4\text{mA}$
 $r_0 > 20\text{k}\Omega$

$$r_0 = \frac{V_A}{I_C}$$

$$\frac{V_A}{I_C} > 20\text{k}\Omega$$

$$V_A > 20\text{k}\Omega \times I_C$$

$$V_A > 20 \times 10^3 \times 4 \times 10^{-3}$$

$$V_A > 80$$

03. Ans: (b)

Sol: $V_A = 100\text{V}$
 $I_C = 1\text{mA}$

$$V_{CE} = 10\text{V}$$

$$I_{CQ} \left(1 + \frac{V_{CE}}{V_A} \right) = I_C$$

$$\text{If } V_A \rightarrow \infty$$

$$\Rightarrow I_C = I_{CQ} = 1\text{mA}$$

04. Ans: (b)

Sol: The phenomenon is known as “Early Effect” in a bipolar transistor refers to a reduction of the effective base-width caused by the reverse biasing of the base-collector junction.

05. Ans: (a)

Sol: Given $\alpha = 0.995$, $I_E = 10\text{mA}$,

$$I_{CO} = 0.5\text{mA}$$

$$I_{CEO} = (1 + \beta) I_{CBO}$$

$$I_{CEO} = \left(1 + \frac{\alpha}{1 - \alpha} \right) I_{CBO}$$

$$I_{CEO} = (1 + 199) \times 0.5 \times 10^{-6}$$

$$I_{CEO} = 100\mu\text{A}$$

06. Ans: (a)

Sol: I_{CBO} is equal to I_{CO} . Reverse leakage current double for every Ten degrees rise in temperature.

07. Ans: (b)

Sol: Given base width $W_B = 50 \times 10^{-6}\text{cm}$

$$\text{Base doping } N_B = 2 \times 10^{16}\text{cm}^{-3}$$

$$\epsilon_r \epsilon_0 = \epsilon \quad \epsilon = 10^{-12}\text{F/cm}$$

$$V_{\text{punch}} = \frac{q N_B W_B^2}{2 \epsilon}$$

$$= \frac{1.6 \times 10^{-19} \times 2 \times 10^{16} \times (50 \times 10^{-6})^2}{2 \times 10^{-12}}$$

$$V_{\text{punch}} = \frac{1.6 \times 2 \times 2500}{2} \times 10^{-3} = 4\text{V}$$

08. Ans: (a)

Sol: $\alpha = 0.98$

$$I_B = 40\mu\text{A}$$

$$I_{CBO} = 1\mu\text{A}$$

$$\beta = \frac{\alpha}{1 - \alpha} = \frac{0.98}{1 - 0.98} = 49$$

For a CE active BJT

$$I_C = \beta I_B + (1 + \beta) I_{CBO}$$

$$= 49 \times 40 \times 10^{-6} + 50 \times 10^{-6}$$

$$= 2.01\text{mA}$$

09. Ans: (b)

Sol: $I_{CBO} = 0.4 \mu A$

$$I_{CEO} = 60 \mu A$$

$$I_{CEO} = (1 + \beta) I_{CBO}$$

$$1 + \beta = \frac{I_{CEO}}{I_{CBO}}$$

$$= \frac{60}{0.4} = 150$$

$$\beta = 150 - 1 = 149$$

$$\alpha = \frac{\beta}{1 + \beta} = \frac{149}{150} = 0.993$$

10. Ans: (c)

Sol: Variation of base width due to reverse biased voltage across collector - base junction is known as "Early Effect".

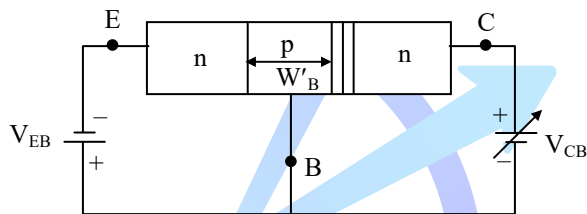

As V_{CB} increases, effective base width (W'_B) decreases.

11. Ans: (b, c & d)

Sol: Condition for saturation

$$\beta \left[\frac{V_{BB} - V_{BE}}{R_B} \right] \geq \frac{V_{CC} - V_{CE(\text{set})}}{R_C}$$

$$50 \left[\frac{5 - 0.7}{50 \times 10^3} \right] \geq \frac{10 - 0.2}{R_C}$$

$$4.3 \text{ mA} \geq \frac{9.8 \text{ V}}{R_C} \Rightarrow R_C \geq \frac{9.8 \text{ V}}{4.3 \text{ mA}}$$

$$\Rightarrow R_C \geq 2279.07 \Omega$$

12. Ans: (a)

Sol: Both Statement (I) and Statement (II) are true and Statement (II) is the correct explanation of Statement (I).

At very high temperature, extrinsic semiconductors will behave as intrinsic i.e., charge carriers will remain constant.

13. Ans: (b)

Sol:

Junction		Region of operation
E - B	C - B	
F. B	F. B	Saturation Region
F. B	R. B	Active Region
R. B	F. B	Inverse active Region
R. B	R. B	Cut-off Region

14. Ans: (c)

Sol: High power transistors are made of Si to withstand high temperature
: Silicon is an indirect band gap material.

Chapter 6 Junction Field Effect Transistor

01. Ans: (d)

Sol: $V_G \rightarrow 4.2 \text{ V to } 4.4 \text{ V}$

$I_D \rightarrow 2.2 \text{ mA to } 2.6 \text{ mA}$

$$g_m = \frac{\Delta I_D}{\Delta V_{GS}}$$

$$= \frac{(2.6 - 2.2) \times 10^{-3}}{4.4 - 4.2}$$

$$= 2 \text{ m}\Omega$$

02. Ans: (c)

Sol:

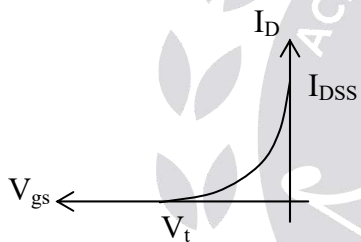

$$V_{gs} = V_t \quad I_D = 0$$

$$V_{gs} = 0 \quad I_D = I_{DSS}$$

03. Ans: (b)

Sol: $I_{Dmax} = I_{DSS} = 10 \text{ mA}$

$$V_P = -4 \text{ V}$$

$$V_{GS} = -1 \text{ V}$$

$$I_D = I_{DSS} \left(1 - \frac{V_{GS}}{V_P} \right)^2$$

$$= 10 \times 10^{-3} \left(1 - \frac{-1}{-4} \right)^2$$

$$= 10 \times 10^{-3} \times \left(\frac{3}{4} \right)^2$$

$$= 5.625 \text{ mA}$$

04. Ans: (d)

Sol:

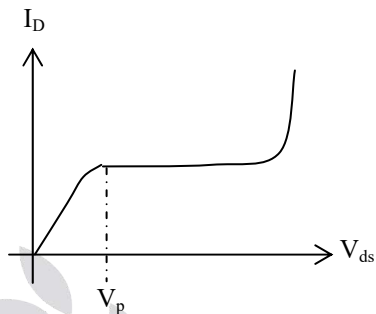

Drain current remains constant at pinch off region even if the drain voltage increases.

05. Ans: (c)

Sol: JFET acts as a voltage controlled current source.

06. Ans: (a)

Sol: Mobility of electron is higher than mobility of hole

Si

Electron mobility : $1350 \text{ cm}^2 / \text{v-s}$

Hole mobility : $450 \text{ cm}^2 / \text{v-s}$

Ge

Electron mobility : $3600 \text{ cm}^2 / \text{v-s}$

Hole mobility : $1800 \text{ cm}^2 / \text{v-s}$

: Low leakage current means high input impedance

: Reverse bias increases, channel width reduces (wedge shaped).

07. Ans: (c)

Sol: $V_P = -8 \text{ V}$

$$I_{DSS} = 12 \text{ mA}$$

From the given circuit,

$$V_G = -5 \text{ V}$$

$$V_S = 0 \text{ V}$$

$$V_{GS} = -5 \text{ V}$$

V_{DS} at which pinch-off region means

$$\begin{aligned} (V_{DS})_{\min} &= V_{GS} - V_P \\ &= -5 - (-8) \\ &= -5 + 8 \\ &= 3 \text{ V} \end{aligned}$$

08. Ans: (d)

Sol: P. Voltage controlled device –FET (3)

Q. Current controlled device –BJT (1)

R. Conductivity modulation device--
IMPATT diode (4)

S. Negative conductance device -UJT (2)

09. Ans: (d)

Sol: $I_{DSS} = 12 \text{ mA}$

$$V_P = -6 \text{ V}$$

$$V_{GS} = 0 \text{ V}$$

$$V_{DS} = 7 \text{ V}$$

At $V_{GS} = 0 \text{ V}$, $I_D = I_{DSS}$

$$= 12 \text{ mA} \left(\because I_D = I_{DSS} \left(1 - \frac{V_{GS}}{V_P} \right)^2 \right)$$

10. Ans: (d)

Sol:

Device :	Application
A. Diode	Rectifier (3)
B. Transistor	Amplifier (1)
C. Tunnel diode	Oscillator (2)
D. Zener diode	Reference Voltage (4)

11. Ans: (a)

Sol: $g_{m0} = \left| \frac{2I_{DSS}}{V_P} \right| = \frac{2 \times 25 \times 10^{-3}}{10} = 5$

12. Ans: (b)

Sol: BJT is current controlled current source

$$(R_i = 0; R_o = \infty)$$

Gain \times B.W is high

FET is voltage controlled current source

$$(R_i = \infty; R_o = 0)$$

Gain \times B.W is low

UJT is a negative resistance device and can be used as an oscillator

UJT can be used as switch but can't be amplification.

13. Ans: (a)

Sol: In FET majority carriers only exist.

In BJT majority & minority carriers exist.

14. Ans: (a)

Sol:

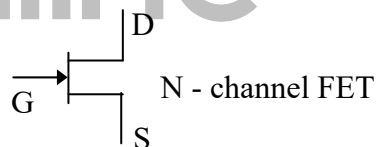

Input resistance of FET is of the order of tens (or) hundreds of mega ohms (M Ω s)

: V_{gs} is reverse bias.

: In reverse bias very small leakage current I_{CO} flows through the gate.

Chapter **7** Optoelectronic Devices

01. Ans: (a)

Sol:

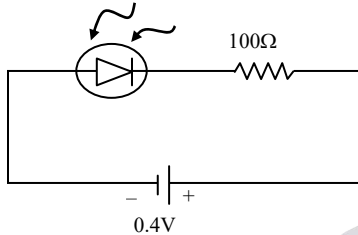

By KVL,

$$0.4 - 100 \times 1.8 \times 10^{-3} - V_p = 0$$

$$V_p = 0.4 - 100 \times 1.8 \times 10^{-3}$$

$$= 0.22 \text{ V}$$

$$V_p = r_p I$$

$$r_p = \frac{V_p}{I}$$

$$= \frac{0.22}{1.8 \times 10^{-3}}$$

$$= 122.22 \Omega$$

02. Ans: (b)

Sol: If illumination doubled then current passing through the photo diode is doubled

$$I_D = 2 \times 1.8 = 3.6 \text{ mA}$$

Voltage across photo diode is

$$= 0.4 - 3.6 \times 10^{-3} \times 100$$

$$= 0.4 - 0.36$$

$$V_p = r_p I_p$$

$$r_p = \frac{V_p}{I_p}$$

$$= \frac{0.04}{3.6} \times 10^3$$

$$= 0.011111 \times 10^3$$

$$= 11.11 \Omega$$

03. Ans: (b)

Sol: Avalanche photo diodes are preferred over PIN diodes in optical communication because Avalanche photo diodes are (APDs), extracted from avalanche gain and excess noise measurement and higher sensitivity. PIN diodes generate more noise.

04. Ans: (c)

Sol: Photo diode always operates in reverse bias. When no light falls on photo diode, Small amount of reverse saturation current flows through the device called “dark current”.

05. Ans: (a)

Sol: Give,

$$E_g = 1.12 \text{ eV}; \lambda_1 = 1.1 \mu\text{m}$$

$$\lambda_2 = 0.87 \mu\text{m}; E_{g2} = ?$$

$$E_g = \frac{12400 \text{ A}^0}{\lambda} \Rightarrow E_g \propto \frac{1}{\lambda}$$

$$\frac{E_{g1}}{E_{g2}} = \frac{\lambda_2}{\lambda_1}$$

$$\Rightarrow E_{g2} = E_{g1} \times \frac{\lambda_1}{\lambda_2} = 1.12 \times \frac{1.1}{0.87}$$

$$= 1.416 \text{ eV}$$

06. Ans: (a)

Sol: Sensitivity of photo diode depends on light intensity and depletion region width.

07. Ans: (d)

$$\text{Sol: } I_D = \frac{24 - 1.8}{820} = 0.02707 \text{ A} = 27.07 \text{ mA}$$

08. Ans: (c)

Sol: Photo diode operate in R.B: Photo diode works on the principle of photo electric effect.

09. Ans: (b)

Sol: Voltage across PN junction diode resulting in current which in turn produce photons and light output. This inversion mechanism also called injection electro luminescence observed in LED's.

10. Ans: (b)

Sol: $\lambda = 890 \text{ \AA}$

$$\lambda = \frac{1.24 \times 10^{-6}}{E_G} \text{ m}$$

$$= \frac{1.24 \times 10^{-6}}{890 \times 10^{-10}}$$

$$= 13.93 \text{ eV}$$

11. Ans: (d)

Sol: Solar cell converts optical (sunlight) energy into electrical energy.

12. Ans: (b)

Sol: $R = 0.45 \text{ A/W}$

$$P_0 = 50 \text{ } \mu\text{W}$$

$$R = \frac{I_p}{P_0}$$

$$I_p = R P_0$$

$$= 0.45 \times 50$$

$$= 22.5 \text{ } \mu\text{A}$$

$$\text{Load current} = I_p + I_0$$

$$= 22.5 \text{ } \mu\text{A} + 1 \text{ } \mu\text{A}$$

$$= 23.5 \text{ } \mu\text{A}$$

13. Ans: (d)

Sol: LED: F.B

Photo diode: R.B

Zener diode: R.B

Ordinary diode: F.B

Tunnel diode: F.B

Variable capacitance diode: R.B

Avalanche diode: R.B

14. Ans: (c)

Sol: Tunnel diode is always operated in forward bias and light operated devices are operated in reverse bias. (Avalanche photo diode).

15. Ans: (b)

Sol: LED's and LASER's are used in forward bias.

Photo diodes are used in reverse bias.

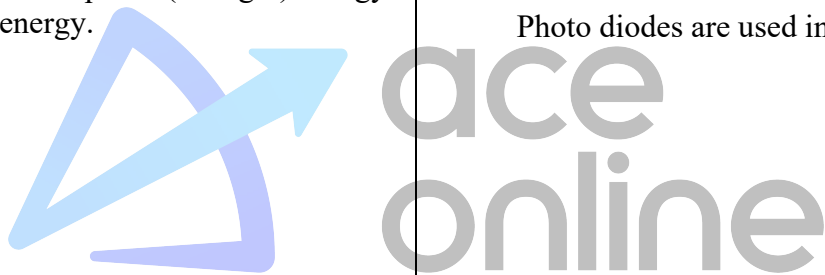

01. Ans: (c)

Sol: $V_T = 1$

$$V_{DS} = 5 - 1 = 4 \text{ V}$$

$$V_{GS} = 3 - 1 = 2 \text{ V}$$

$$V_{GS} - V_T = 2 - 1 = 1 \text{ V}$$

$$V_{DS} > V_{GS} - V_T$$

$$4 > 1 \rightarrow \text{Saturation}$$

02. Ans: (d)

Sol: In active region (or) saturation region, channel is pinched off. Number of carriers present in the channel decreases from source end to drain end due to potential increases from source to drain.

03. Ans: (d)

$$\text{Sol: } \frac{I_{D2}}{I_{D1}} = \frac{K_n [V_{GS2} - V_T]^2}{K_n [V_{GS1} - V_T]^2}$$

$$\frac{I_{D2}}{1 \text{ mA}} = \frac{[1400 - 400]^2}{[900 - 400]^2}$$

$$I_{D2} = 4 \text{ mA}$$

04. Ans: (d)

Sol: $A = 1 \text{ sq } \mu\text{m} = 10^{-12} \text{ m}^2$

$$d = 1 \text{ } \mu\text{m} = 1 \times 10^{-6} \text{ m}$$

$$N_D = 10^{19} / \text{cm}^3$$

$$n_i = 10^{10}$$

No. of holes = concentration \times volume

$$\text{Volume} = A \times d = 10^{-18} \text{ m}^3$$

$$p = \frac{n_i^2}{n} = \frac{10^{20}}{10^{19}}$$

$$= 10 \text{ holes/cm}^3 = 10 \times 10^6 \text{ holes/m}^3$$

$$\therefore \text{No. of holes} = 10 \times 10^6 \times 10^{-18}$$

$$= 10^{-11} \text{ holes}$$

$$\approx 0$$

05. Ans: (b)

Sol: 1) since it has n-type source & drain, it is n-channel MOSFET.

2) Drain current flows only when $V_{GS} > 2V$, it implies it has threshold voltage (V_{th}) of +2V

\Rightarrow It is enhancement type MOSFET.

$$3) V_{Th} = +2V$$

$$4) g_m = \mu_n C_{ox} \frac{W}{L} [V_{GS} - V_{Th}],$$

transconductance depends upon electron mobility.

06. Ans: (b)

$$\text{Sol: } C_{sbo} = \frac{\epsilon_{si} A}{d}$$

$$d = 10 \text{ nm}$$

$$\epsilon_{si} = \epsilon_{rsi} \epsilon_0$$

$$= 11.7 \times 8.9 \times 10^{-12} \text{ F/m}$$

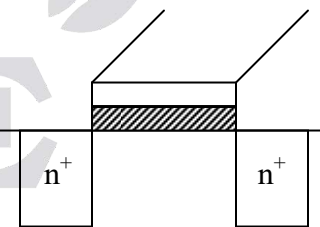

$$A = (0.2 \mu\text{m} \times 1 \mu\text{m}) + (0.2 \mu\text{m} \times 1 \mu\text{m}) + (0.2 \mu\text{m} \times 1 \mu\text{m})$$

$$= 3(0.2 \mu\text{m} \times 1 \mu\text{m}) = 0.6 \times 10^{-12} \text{ m}^2$$

$$C_{sbo} = \frac{11.7 \times 8.9 \times 10^{-12} \times 0.6 \times 10^{-12}}{10 \times 10^{-9}}$$

$$C_{sbo} = 6.24 \times 10^{-15}$$

$$\approx 7 \text{ fF}$$

In practical IC, this cap will provided to front and back sides also then area may be

$$A = (0.6 \times 10^{-12}) + (0.2 \mu \times 1 \mu) + (0.2 \mu \times 1 \mu)$$

$$A = 0.68 \times 10^{-12} \text{ m}^2$$

$$C_{sbo} = \frac{11.7 \times 8.9 \times 10^{-12} \times 0.68 \times 10^{-12}}{10 \times 10^{-9}} = 7 \text{ fF}$$

07. Ans: (a)

Sol: $L_{ov} = \delta = 20 \text{ nm}$

$$d = 10 \text{ nm}, w = 1 \mu \text{m}$$

$$\epsilon_{rsi} = 11.7, \epsilon_{rox} = 3.9$$

$$\epsilon_0 = 8.9 \times 10^{-12} \text{ F/m}$$

$$C_{ov} = C_{ox} w L_{ov} = \frac{\epsilon_{ox}}{t_{ox}} w L_{ov}$$

$$= \frac{\epsilon_{rox} \epsilon_0}{t_{ox}} w L_{ov}$$

$$= \frac{3.9 \times 8.9 \times 10^{-12} \times 1 \times 10^{-6} \times 20 \times 10^{-9}}{1 \times 10^{-9}}$$

$$= 0.69 \times 10^{-15} = 0.69 \text{ fF} \approx 0.7 \text{ fF}$$

08. Ans: (a)

Sol: $A = 1 \times 10^{-4} \text{ cm}^2$

$$\epsilon_{si} = 1 \times 10^{-12} \text{ F/cm}$$

$$\epsilon_{ox} = 3.5 \times 10^{-13} \text{ F/cm}$$

$$C_0 = 7 \text{ pF}$$

$$C_0 = C_{ox} A = \frac{\epsilon_{ox} A}{t_{ox}}$$

$$t_{ox} = \frac{\epsilon_{ox}}{C_0} A = \frac{3.5 \times 10^{-13} \times 1 \times 10^{-4}}{7 \times 10^{-12}}$$

$$= 5 \times 10^{-6} \text{ cm} = 50 \text{ nm}$$

09. Ans: (b)

Sol: $\frac{C_0 C_d}{C_0 + C_d} = 1 \text{ pF}$

$$\frac{7 C_d}{C_d + 7} = 1 \Rightarrow C_d = \frac{7}{6} \text{ pF}$$

$$C_d = C_{dep} A = \frac{\epsilon_{si}}{d} A$$

$$d = \frac{\epsilon_{si}}{C_d} A$$

$$= \frac{1 \times 10^{-12}}{\frac{7}{6} \times 10^{-12}} (1 \times 10^{-4}) \text{ cm} = 0.857 \mu \text{m}$$

10. Ans: (b)

Sol: $V_{Th} = 0.5 \text{ V}$

$$V_G = 3 \text{ V}$$

Pinch-off occurs when

$$V_D = V_G - V_{Th} = 3 - 0.5 = 2.5 \text{ V}$$

11. Ans: (a)

Sol:

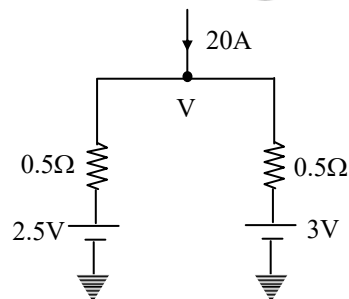
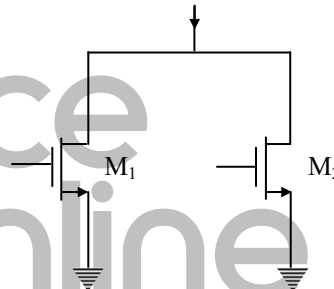

$$20 = \frac{V - 2.5}{0.5} + \frac{V - 3}{0.5}$$

$$V = 7.75 \text{ Volts}$$

$$I_{D1} = \frac{7.75 - 2.5}{0.5} = 10.5 \text{ A}$$

$$I_{D2} = \frac{7.75 - 3}{0.5} = 9.5 \text{ A}$$

12. Ans: (a & c)

$$\text{Sol: } X_{d\max} = \sqrt{\frac{2\epsilon_s \phi_t}{qN_A}} = \sqrt{\frac{4\epsilon_s \phi_F}{qN_A}}$$

$$\phi_F = V_t \ln\left(\frac{N_A}{n_i}\right) = 0.026 \ln\left(\frac{10^{15}}{1.5 \times 10^{10}}\right)$$

$$= 0.29\text{V}$$

$$X_{d\max} = \sqrt{\frac{4 \times 11.7 \times 8.854 \times 10^{-14} \times 0.29}{0.6 \times 10^{-19} \times 10^{15}}}$$

$$= 8.67 \times 10^{-5} \text{ cm} = 8.67 \times 10^{-7} \text{ m} = 0.867 \mu\text{m}$$

$$|Q_{\text{div}}| = qN_A X_{d\max}$$

$$= 1.6 \times 10^{-19} \times 10^{15} \times 0.867 \times 10^{-5}$$

$$= 1.39 \text{ nc/cm}^2$$

$$C_{\text{ox}} = \frac{\epsilon_{\text{ox}}}{t_{\text{ox}}} = \frac{3.9 \times 8.854 \times 10^{-14}}{10 \times 10^{-7}}$$

$$= 3.45 \times 10^{-7} \text{ F/cm}^2 = 0.345 \mu\text{F/cm}^2$$

$$V_T = \frac{|Q_{\text{div}}|}{C_{\text{ox}}} + Q_t = \frac{|Q_{\text{div}}|}{C_{\text{ox}}} + 2\phi_F$$

$$= \frac{1.39 \times 10^{-9}}{0.345 \times 10^{-6}} + 2 \times 0.29$$

$$= 0.58\text{V}$$

13. Ans: (a, c & d)

$$\text{Sol: } V_{\text{TH}} = \frac{\sqrt{2qN_A \epsilon_s (2\phi_B)}}{C_{\text{ox}}} + 2\phi_B + V_{\text{BF}},$$

$$C_{\text{ox}} = \frac{\epsilon_{\text{ox}}}{t_{\text{ox}}}$$

As V_{TH} is proportional to channel dopant concentration and gate-oxide thickness.

$\therefore V_{\text{TH}}$ can be increased by increasing channel dopant concentration & gate-oxide thickness and also V_{TH} can be increased by increasing channel length.

Since 1995

ACE

Chapter 9

Biasing

JFET Biasing

01. Ans: (c)

$$\text{Sol: } R_D = \frac{V_{DD} - V_D}{I_D} = \frac{20V - 12V}{2.5mA} = 3.2 K\Omega$$

In self bias

$$V_{GS} = -I_D R_S$$

$$I_D = I_{DSS} \left(1 - \frac{V_{GS}}{V_P} \right)^2$$

$$V_{GS} = V_P \left(1 - \sqrt{\frac{I_D}{I_{DSS}}} \right)$$

$$V_{GS} = -1.06 V$$

$$R_S = \frac{V_{GS}}{-I_D} = \frac{-1}{-2.5} = 400 \Omega$$

02. Ans: (b)

$$\text{Sol: } V_G = V_{GS} + I_D R_S$$

$$I_D = \frac{16 - 8}{1.8 K} = 4.4 \text{ mA}$$

$$V_G = \frac{16 \times 47}{138} = 5.45 V$$

$$R_S = \frac{V_G - V_{GS}}{I_D} = \frac{5.4 - (-2V)}{4.4 \text{ m}} = 1.68 K\Omega$$

03. Ans: (c)

$$\text{Sol: } V_{DS} = V_{DD} - I_D(R_D + R_S) \\ = 30 V - 4 \text{ mA}(3.3K + 1.5K)$$

$$V_{DS} = 10.8 V$$

04. Ans: (b)

Sol: AC analysis,

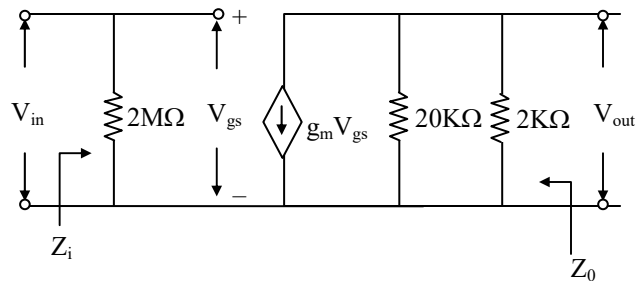

$$Z_i = 2M\Omega,$$

$$Z_o = 20K\Omega \parallel 2K\Omega$$

$$\Rightarrow Z_o = \frac{20}{11} K\Omega$$

05. Ans: (a)

$$\text{Sol: } I_D = I_{DSS} \left[1 - \frac{V_{GS}}{V_P} \right]^2$$

$$= 10 \times 10^{-3} \left[1 - \frac{-2}{-8} \right]^2 = 5.625 \text{ mA}$$

KVL at output loop,

$$-20 + (2 \times 10^3 I_D) + V_{DS} = 0$$

$$V_{DS} = 20 - (2 \times 10^3 \times 5.625 \times 10^{-3}) \\ = 8.75 V$$

06. Ans: (b) (By Printing Mistake in Volume-I Answer (c) is wrong, Correct answer is (b))

Sol: By observing,

The circuit is common drain i.e., source follower circuit.

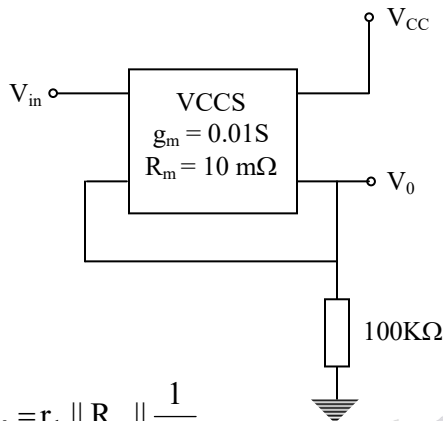

$$R_0 = r_d \parallel R_s \parallel \frac{1}{g_m}$$

$$= 10 \text{ M}\Omega \parallel 100 \text{ K}\Omega \parallel 100 \Omega$$

$$= 100 \Omega$$

FREQUENCY ANALYSIS

01. Ans: (d)

Sol:

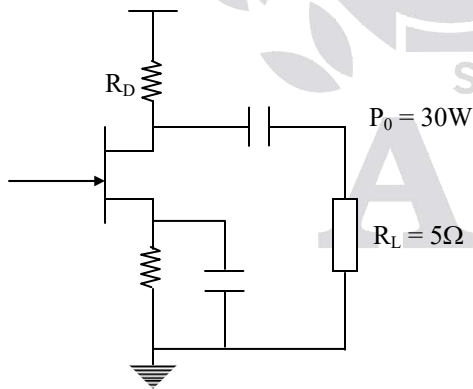

$$P_0 = \frac{V_0^2}{R_L}$$

$$30 \times 5 = V_0^2$$

$$V_0 = 12.25 \text{ V}$$

$$A_v = \frac{V_0}{V_i}$$

$$A_{v(\text{dB})} = 20 \log_{10} A_v$$

$$20 = 20 \log_{10} A_v$$

$$A_v = 10^1 = 10$$

$$\frac{V_0}{V_i} = 10$$

$$V_i = \frac{V_0}{10} = \frac{12.25}{10} \text{ V} = 1.225 \text{ V}$$

02. Ans: (b)

Sol: $A_{v(\text{dB})} = 20 \log_{10} A_v$

$$50 = 20 \log_{10} A_v$$

$$A_v = 10^{(5/2)} = 316.228$$

03. Ans: $6.123 \times 10^6 \text{ Hz}$

Sol: Small signal equivalent

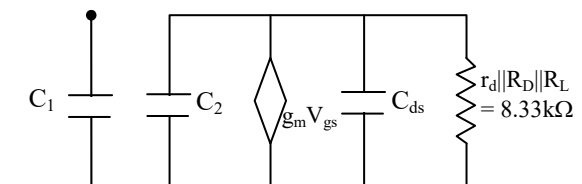
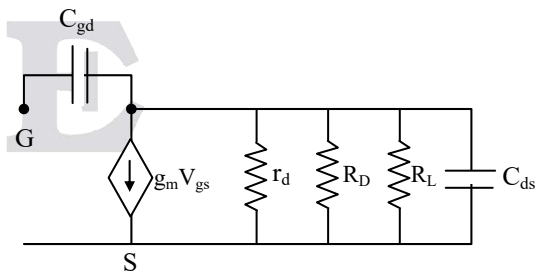

$$C_2 = C_{gd} \left(1 - \frac{1}{A_v} \right),$$

$A_v = \text{mid-band,}$

$$\text{gain} = g_m(r_d || R_D || R_L) = -16.66$$

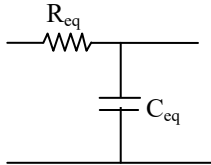

$$C_2 = 2\text{pF} \left(1 - \frac{1}{-16.66} \right) = 2.12 \text{ pF}$$

$$f_H = \frac{1}{2\pi C_{eq} R_{eq}}$$

$$C_{eq} = 1 + 2.12 = 3.12 \text{ pF, } R_{eq} = 8.33\text{k}\Omega$$

$$\Rightarrow f_H = 6.123 \times 10^6 \text{ Hz}$$

MOSFET BIASING

01. Ans: (b)

Sol:

$$V_T = 0.8$$

$$K_n = 30 \times 10^{-6}$$

$$\left(\frac{W_1}{L} \right)_1 = \left(\frac{W}{L} \right)_2 = 40$$

$$V_{D_1} = +5$$

$$I_{D_1} = I_{D_2}$$

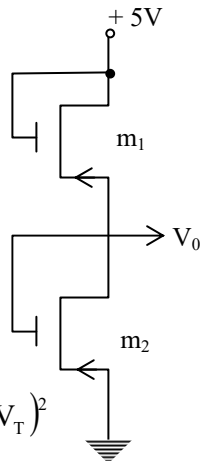

$$\frac{1}{2} \mu_n C_{ox} \left(\frac{W}{L} \right)_1 (V_{GS_1} - V_T)^2$$

$$= \frac{1}{2} \mu_n C_{ox} \left(\frac{W}{L} \right)_2 (V_{GS_2} - V_T)^2$$

$$V_{GS_1} = V_{D_1} - V_0$$

$$= +5 - V_0$$

$$V_{GS_2} = V_{G_1} - V_S$$

$$= V_0 - 0 = V_0$$

$$\left(\frac{W}{L} \right)_1 (5 - (V_0) - 0.8)^2 = \left(\frac{W}{L} \right)_2 (V_0 - 0.8)^2$$

$$V_0 = 2.5\text{V}$$

02. Ans: (a)

$$\text{Sol: } \left(\frac{W}{L} \right)_1 (V_{GS_1} - V_T)^2 = \left(\frac{W}{L} \right)_2 (V_{GS_2} - V_T)^2$$

$$40 (4.2 - V_0)^2 = 15 (V_0 - 0.8)^2$$

$$V_0 = 2.91 \text{ V}$$

03. Ans: (c)

Sol: From figure $I_{DS1} = I_{DS2}$.

$$\frac{1}{2} \mu_n C_{ox} \left(\frac{W}{L} \right)_1 (V_{GS_1} - V_t)^2$$

$$= \frac{1}{2} \mu_n C_{ox} \left(\frac{W}{L} \right)_2 (V_{GS_2} - V_t)^2$$

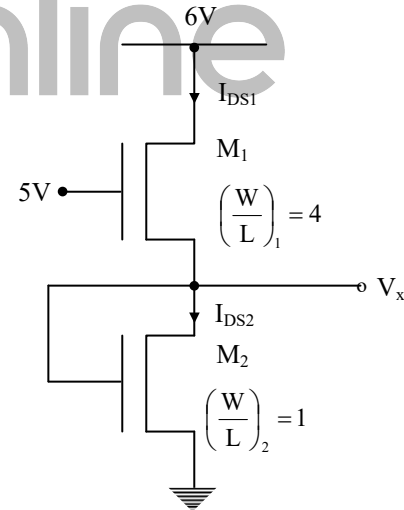

$$\therefore 4(5 - V_x - V_t)^2 = 1(V_x - V_t)^2$$

$$(\because V_{GS1} = V_G - V_x = 5 - V_x)$$

$$\Rightarrow 2(5 - V_x - V_t) = (V_x - V_t)$$

$$\therefore V_x = 3\text{V}$$

04. Ans: (d)

Sol:
$$\frac{V_2}{V_i} = \frac{g_m R_s}{1 + g_m R_s} \text{----- (1)}$$

$$\frac{V_1}{V_i} = \frac{-g_m R_D}{1 + g_m R_s} \text{----- (2)}$$

$$(1) \div (2) \Rightarrow$$

$$\frac{V_2}{V_1} = \frac{R_s}{-R_D}$$

$$\frac{V_2}{V_1} = \frac{-1}{2}$$

$$V_1 = -2V_2$$

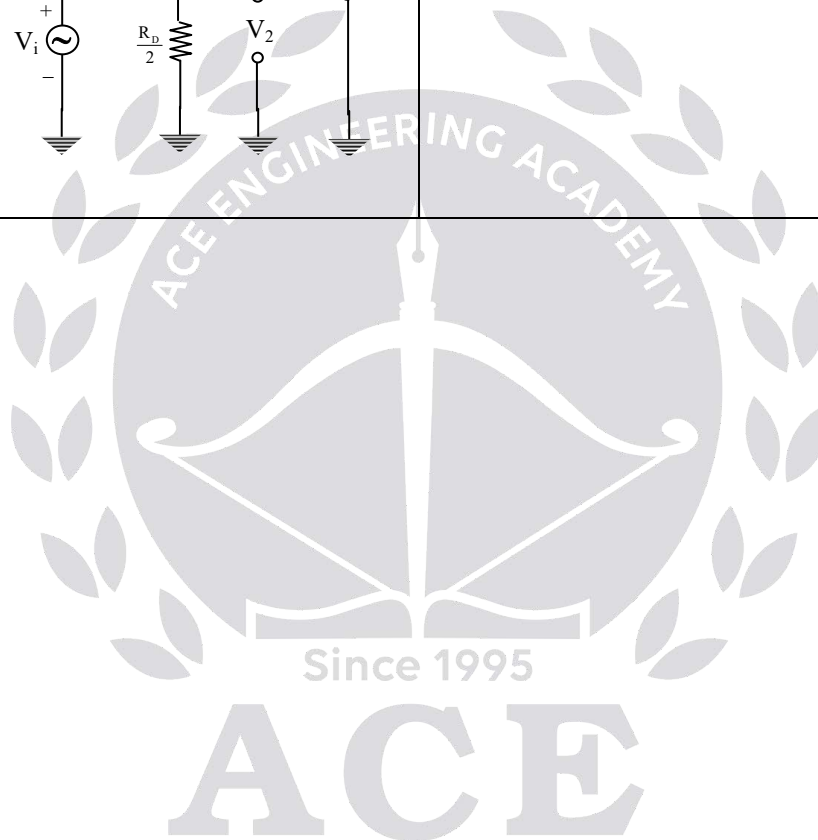
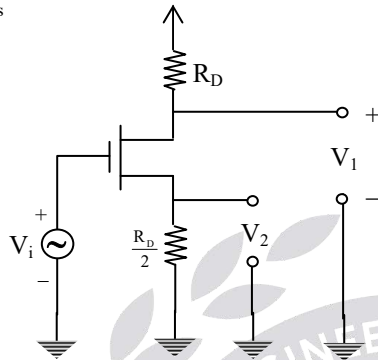

Chapter 10 CMOS & Device Technology

01. Ans: (c)

Sol: $\overline{A(B+C)+DE}$

After option (c) as above answer.

02. Ans: (a)

Sol: $\overline{x_1 + x_2}$

03. Ans: (d)

Sol: V_{dd}

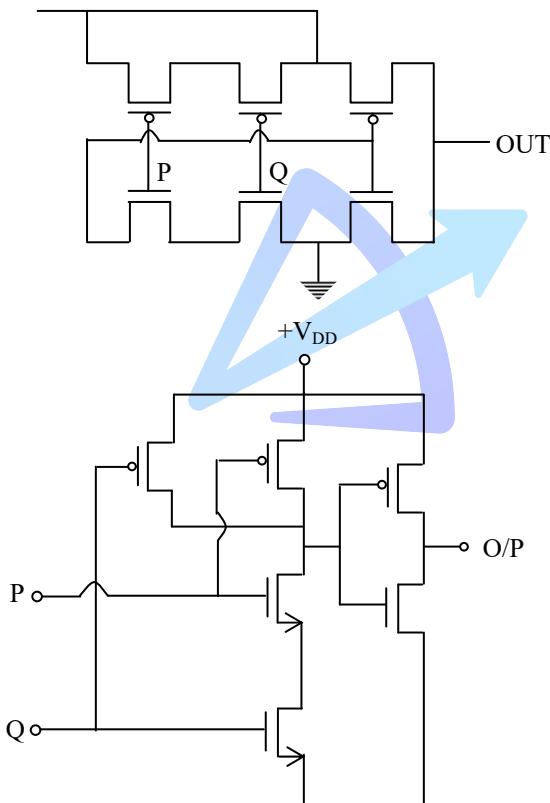

AND gate

04. Ans: (b)

Sol: $n = \frac{1}{2Nf}$

$$n = \frac{1}{2 \times 5 \times 10^6} = 10^{-8} \text{ sec} = 10 \text{ n sec}$$

05. Ans: (a, b & c)

Sol:

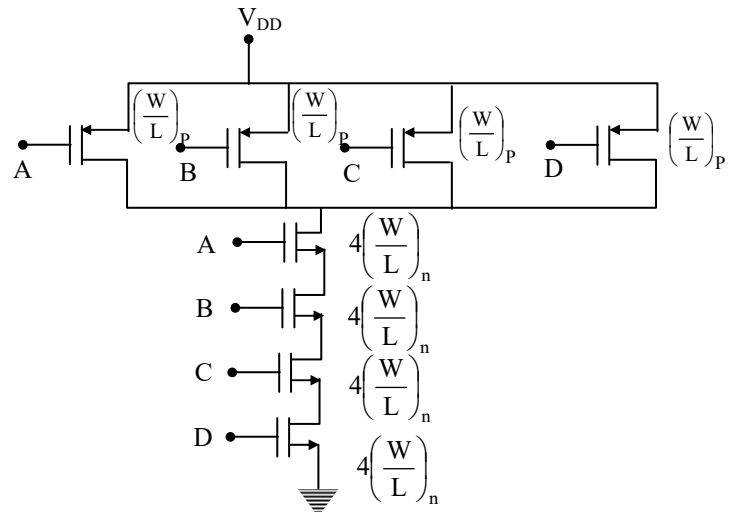

For basic inverter $W_N = 2\mu\text{m}$, to get symmetrical voltage transfer characteristics

$$\frac{W_p}{W_n} = \frac{\mu_n}{\mu_p} = 3$$

$$W_p = 3W_n = 6\mu\text{m}$$

* Width of NMOS in NAND gate = $4W_n = 8\mu\text{m}$

* Width of PMOS in NAND gate = $W_p = 6\mu\text{m}$

Device Technology Key

01. (c) 02. (b) 03. (d)
04. (b) 05. (a)