



GATE | PSUs

CIVIL ENGINEERING

Engineering Mechanics & Strength of Materials

**(Text Book : Theory with worked out Examples
and Practice Questions)**



Engineering Mechanics

(Solutions for Text Book Practice Questions)

Chapter

1

Force and Moment Systems

01. Ans: (b)

Sol:

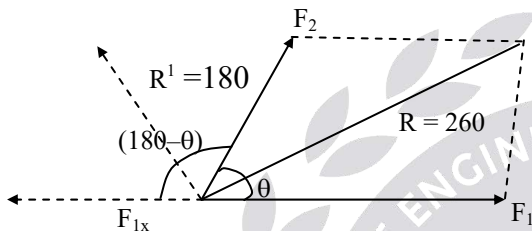

Assume $F_1 = 2F_2$ ($F_1 > F_2$)

$$F_{1x} = 2F_2$$

$$R = \sqrt{F_1^2 + F_2^2 + 4F_2^2 \cos \theta}$$

$$260 = \sqrt{4F_2^2 + F_2^2 + 4F_2^2 \cos \theta}$$

$$260^2 = 5F_2^2 + 4F_2^2 \cos \theta \quad \text{----- (1)}$$

$$R^1 = \sqrt{F_{1x}^2 + F_2^2 + 2F_{1x}F_2 \cos \theta}$$

$$180 = \sqrt{4F_2^2 + F_2^2 + 2F_2 \cdot F_2 \cos(180 - \theta)}$$

$$180^2 = 5F_2^2 - 4F_2^2 \cos \theta \quad \text{----- (2)}$$

$$260^2 = 5F_2^2 + 4F_2^2 \cos \theta$$

$$180^2 = 5F_2^2 - 4F_2^2 \cos \theta$$

$$260^2 + 180^2 = 10F_2^2$$

$$\Rightarrow F_2 = 100\text{N},$$

$$260^2 = 5(100)^2 + 4(100)^2 \cos \theta$$

$$\Rightarrow \theta = 63.89^\circ$$

Where θ angle between two forces.

02. Ans: (b)

Sol: Let the angle between the forces be θ

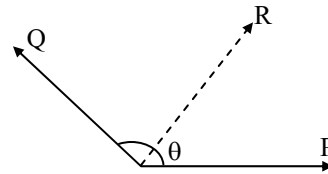

Where, R is the resultant of the two forces.

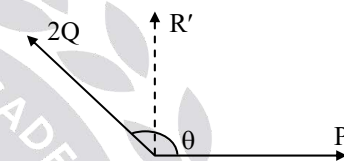

If Q is doubled i.e., $2Q$ then resultant (R') is perpendicular to P.

$$\tan 90 = \frac{2Q \sin \theta}{P + 2Q \cos \theta}$$

$$\Rightarrow P + 2Q \cos \theta = 0$$

$$P = -2Q \cos \theta \quad \text{----- (i)}$$

$$\text{Also, } R = \sqrt{P^2 + Q^2 + 2PQ \cos \theta}$$

$$R = Q \text{ [using eq.(i)]}$$

03. Ans: (b)

Sol: Since moment of F about point A is zero.

\therefore F passes through point A,

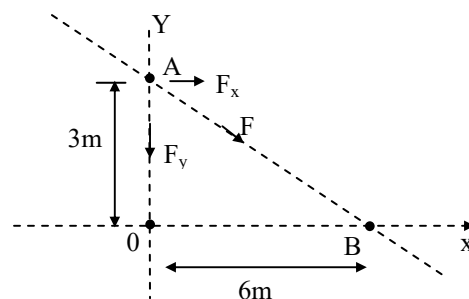

$$M_0^F = 180\text{N} - m$$

$$M_B^F = 90\text{N} - m$$

$$M_A^F = 0$$

$$M_0^F = 180 = F_x \times 3 + F_y \times 0$$

$$F_x = 60\text{N} \dots\dots (1)$$

$$M_B^F = F_x \times 3 - F_y \times 6 = -90$$

$$60 \times 3 - 6F_y = -90$$

$$\Rightarrow F_y = \frac{270}{6}$$

$$F_y = 45\text{N}$$

$$\therefore F = \sqrt{F_x^2 + F_y^2} = \sqrt{60^2 + 45^2} = 75\text{N}$$

04. Ans: (a)

Sol:

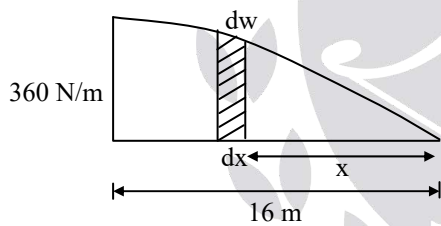

$$\int_0^w dw = \int_0^w w dx$$

$$w = \int_0^{16} 90\sqrt{x} dx = 90 \left[\frac{x^{\frac{1}{2}+1}}{\frac{1}{2}+1} \right]_0^{16}$$

$$= 90 \times \frac{2}{3} \left[x^{3/2} \right]_0^{16} = 60 (16)^{3/2}$$

$$w = 3840\text{N}$$

The moment due to average force should be equal to the variable force

$$R \times d = \Sigma dw \times x$$

$$3840 \times d = \int_0^{16} 90\sqrt{x} \cdot dx \cdot x$$

$$= 90 \int_0^{16} x^{1.5} dx$$

$$3840d = 90 \left[\frac{x^{2.5}}{2.5} \right]_0^{16}$$

$$\Rightarrow d = 9.6\text{m}$$

05. Ans: (c)

Sol: Moment about 'O'

$$M_0 = 100 \sin 60 \times 3$$

$$= 300 \times \frac{\sqrt{3}}{2} = 150\sqrt{3}$$

$$= 259.8 \approx 260\text{N}$$

06. Ans: (a)

Sol:

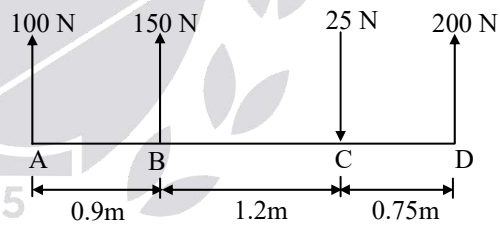

$$F_R = \Sigma F_y$$

$$F_R = 100 + 150 - 25 + 200 \text{ (upward force positive and downward force negative)}$$

$$R = 425\text{N}$$

For equilibrium

$$\Sigma M_A = 0 \text{ (since } R = \text{resultant)}$$

Let R is acting at a distance of 'd'

$$425 \times d = 150 \times 0.9 + 25 \times 2.1 - 200 \times 2.85$$

$$\Rightarrow d = 1.535\text{m (from A)}$$

Chapter

2

Equilibrium of Force System

01. Ans: (d)

Sol:

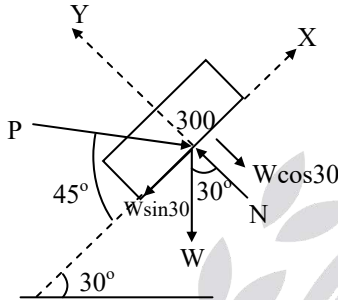

Resolve the forces along the inclined surface

$$\sum F_x = 0$$

$$P \cos 45 - W \sin 30 = 0$$

$$P = \frac{300 \sin 30}{\cos 45} \Rightarrow P = 212.13 \text{ N}$$

02. Ans: (a)

Sol:

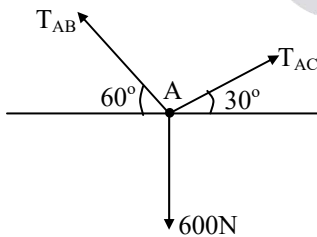

$$T_{AB} \cos 60^\circ = T_{AC} \cos 30^\circ$$

$$T_{AB} = \sqrt{3} T_{AC}$$

$$T_{AB} \sin 60^\circ + T_{AC} \sin 30^\circ = 600 \text{ N}$$

$$\frac{3}{2} T_{AC} + \frac{1}{2} T_{AC} = 600$$

$$\Rightarrow T_{AB} = 520 \text{ N}; \quad T_{AC} = 300 \text{ N}$$

03. Ans: (c)

Sol:

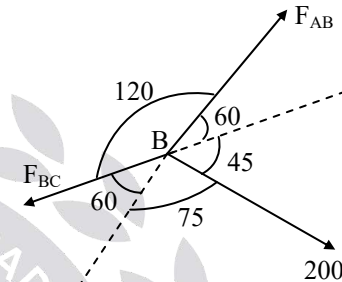
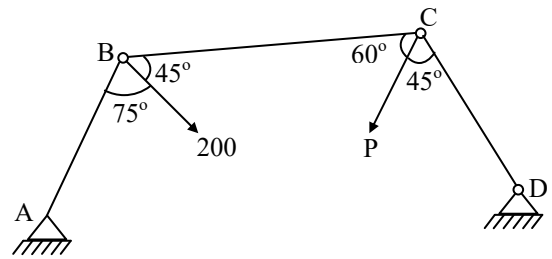

Fig: Free body diagram at 'B'

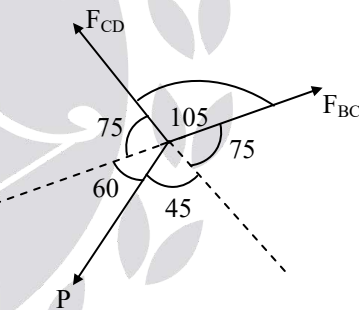

Fig: Free body diagram at 'C'

For Equilibrium of Point 'B'

$$\frac{F_{AB}}{\sin(60 + 75)} = \frac{F_{BC}}{\sin(60 + 45)} = \frac{200}{\sin(120)}$$

$$F_{BC} = 223.07 \text{ N}$$

From Sine rule at "C".

$$\frac{F_{CD}}{\sin(75 + 45)} = \frac{F_{BC}}{\sin(60 + 75)} = \frac{P}{\sin 105}$$

$$P = \frac{223.07 \times \sin 105}{\sin 135}$$

$$P = 304.71 \text{ N}$$

04. Ans: (d)

Sol:

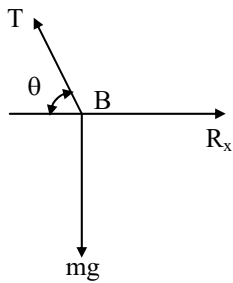

$$\tan\theta = \frac{125}{275} \Rightarrow \theta = 24.45^\circ$$

$$T \sin\theta = mg$$

$$T \sin 24.45 = (35 \times 9.81)$$

$$T = 829.5 \text{ N}$$

$$R_x = T \cos 24.45 = 755.4 \text{ N}$$

$$R_y = 0$$

05. Ans: (c)

Sol:

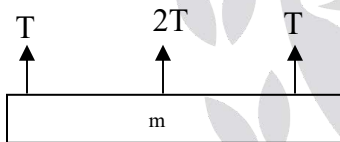

$$T + 2T + T = mg$$

$$4T = mg$$

$$m = 4T/g$$

06. Ans: (b)

Sol:

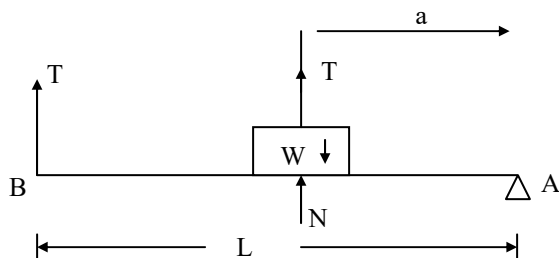

For body, $\Sigma F_y = 0$

$$N - W + T = 0$$

$$\Rightarrow N = W - T$$

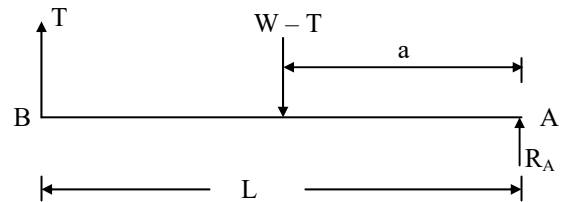

$\Sigma F_y = 0$ for entire system

$$R_A + T - (W - T) = 0$$

$$R_A = W - 2T \quad \text{----- (1)}$$

For equilibrium

$$\Sigma M_A = 0$$

$$T \times L = (W - T) a$$

$$TL = Wa - Ta$$

$$TL + Ta = Wa$$

$$T(L + a) = Wa$$

$$\Rightarrow T = \frac{Wa}{L + a}$$

T substitute in equation (1)

$$R_A = W - 2\left(\frac{Wa}{L + a}\right)$$

$$= \frac{W(L + a) - 2Wa}{L + a}$$

$$= \frac{WL + Wa - 2Wa}{L + a}$$

$$= \frac{WL - Wa}{L + a}$$

$$R_A = \frac{W(L - a)}{L + a}$$

07. Ans: (c)

Sol:

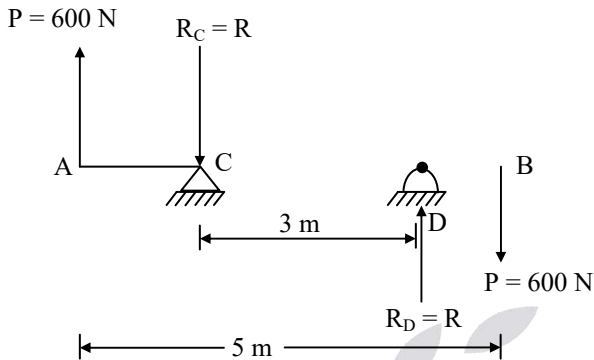

$$\sum F_y = 0$$

$$600 - R_C + R_D - 600 = 0$$

$$\Rightarrow R_C = R_D = R$$

$$\sum M = 0$$

$$600 \times 5 = R \times 3$$

$$\Rightarrow R = 1000 \text{ N} = R_C = R_D$$

08. Ans: (a)

Sol: F.B.D

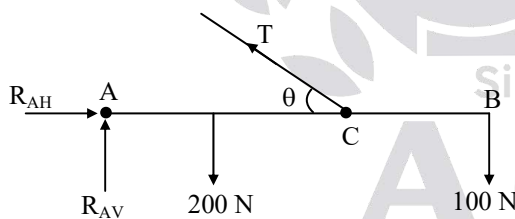

$$\sum M_A = 0$$

$$\tan \theta = \frac{8}{4}$$

$$\theta = 63.43$$

$$T \sin \theta \times 4 (\cup) - 200 \times 2 (\cup) - 100 \times 6 (\cup) = 0$$

$$\Rightarrow T = 279.5 \text{ N}$$

$$\text{Now, } \sum F_x = 0,$$

$$R_{AH} - T \cos \theta = 0$$

$$R_{AH} = 125 \text{ N}$$

$$\sum F_y = 0$$

$$R_{AV} - 200 - 100 + T \sin \theta = 0$$

$$\Rightarrow R_{VA} = 50 \text{ N}$$

09. Ans: 400 N

Sol:

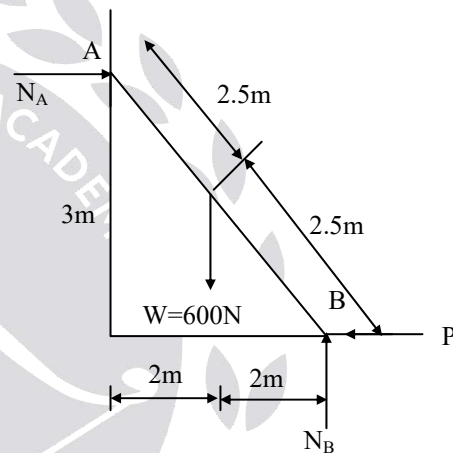

$$\sum F_y = 0$$

$$N_B - W = 0$$

$$N_B = 600 \text{ N}$$

$$\sum M_A = 0$$

$$P \times 3 + W \times 2 - N_B \times 4 = 0$$

$$P = \frac{4N_B - 2W}{3}$$

$$P = \frac{4 \times 600 - 2 \times 600}{3} = 400 \text{ N}$$

Chapter
3

Friction

01. Ans: (c)

Sol: The FBD of the above block shown

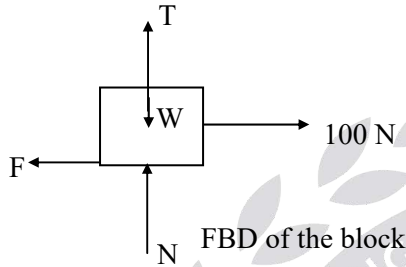

$$\Sigma Y = 0 \Rightarrow N + T - W = 0$$

$$N = W - T = 981 - T$$

$$F = \mu N = 0.2(981 - T)$$

$$\Sigma X = 0 \Rightarrow 100 - F = 0$$

$$F = 100 = 0.2(981 - T)$$

$$\Rightarrow T = 481 \text{ N}$$

02. Ans: (c)

Sol: Given $\tan \theta = \frac{3}{4}$

$$\sin \theta = \frac{3}{5}$$

$$\cos \theta = \frac{4}{5}$$

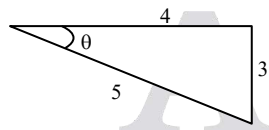

Free body diagram for block (2)

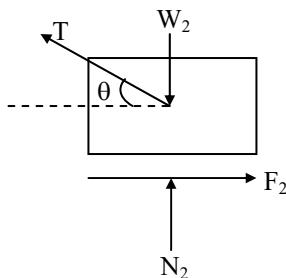

Free body diagram for block (1)

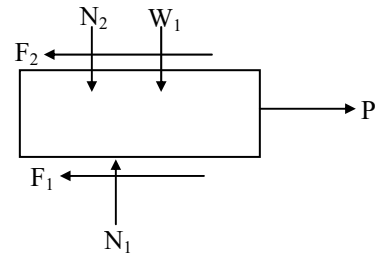

From FBD of block (2)

$$\Sigma F_x = 0$$

$$F_2 = T \cos \theta$$

$$F_2 = \frac{4}{5} T = 0.8T \text{ ----- (1)}$$

$$\Sigma F_y = 0$$

$$N_2 + T \sin \theta - W_2 = 0$$

$$N_2 = W_2 - T \sin \theta$$

$$N_2 = 50 - 0.6T$$

$$\text{But } F_2 = \mu N_2$$

$$\Rightarrow F_2 = 0.3(50 - 0.6T)$$

$$F_2 = 15 - 0.18T \text{ ----- (2)}$$

From (1) & (2)

$$0.8T = 15 - 0.18T$$

$$\Rightarrow 0.98T = 15$$

$$\Rightarrow T = 15.31 \text{ N}$$

$$\therefore N_2 = 50 - 0.6T$$

$$= 50 - 0.6(15.31) = 40.81 \text{ N}$$

$$F_2 = \mu N_2 = 0.3 \times 40.81 = 12.24 \text{ N}$$

From FBD of block (1)

$$\Sigma F_y = 0$$

$$N_1 - N_2 - W_1 = 0$$

$$N_1 = N_2 + W_1 = 40.81 + 200 = 240.81 \text{ N}$$

$$F_1 = \mu N_1 \Rightarrow F_1 = 0.3 \times 240.81$$

$$F_1 = 72.24 \text{ N}$$

$$\Sigma F_x = 0$$

$$P - F_1 - F_2 = 0$$

$$P = F_1 + F_2 = 72.24 + 12.24$$

$$P = 84.48 \text{ N}$$

03. Ans: (b)

Sol: Free Body Diagram

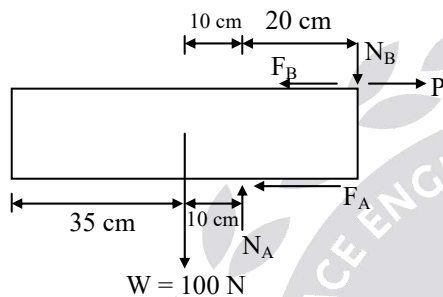

$$F_A = \mu N_A = \frac{1}{3} N_A$$

$$F_B = \mu N_B = \frac{1}{3} N_B$$

$$\Sigma M_B = 0$$

$$-100 \times 30 (\cup) + (N_A \times 20) (\cup) + (F_A \times 12) (\cup) = 0$$

$$-3000 + N_A \times 20 + \frac{1}{3} N_A \times 12 = 0$$

$$\Rightarrow N_A = 125 \text{ N}$$

$$\Sigma F_y = 0$$

$$N_A - N_B - 100 = 0$$

$$\Rightarrow N_B = 25 \text{ N}$$

$$\Sigma F_x = 0$$

$$P = F_A + F_B = \frac{1}{3} (N_A + N_B)$$

$$= \frac{1}{3} (125 + 25) = 50 \text{ N}$$

04. Ans: (d)

Sol: F.B.D of both the books are shown below.

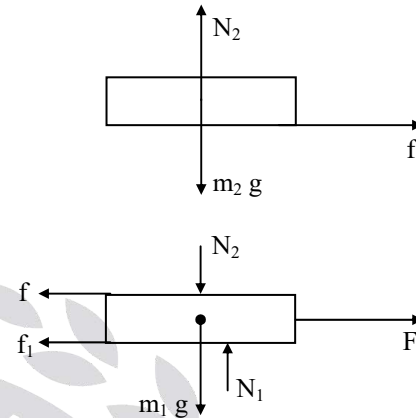

where, f is the friction between the two books.

f_1 is the friction between the lower book and ground.

Now, maximum possible acceleration of upper book.

$$a_{\max} = \frac{f_{\max}}{m_2} = \frac{\mu m_2 g}{m_2} = \mu \times g$$

$$= 0.3 \times 9.81 = 2.943 \text{ m/s}^2$$

For slip to occur, acceleration (a_1) of lower book. i.e., $a_1 \geq a_{\max}$

$$\frac{F - f - f_1}{m_1} \geq 2.943$$

$$F - 2.943 - 0.3 \times 2 \times 9.81 \geq 2.943$$

$$[\because f = f_{\max} = 2.943 \text{ and}$$

$$f_1 = \mu \times (m_1 + m_2) g = 0.3 \times 2 \times 9.81]$$

$$F \geq 11.77 \text{ N}$$

$$F_{\min} = 11.77 \text{ N}$$

05. Ans: (d)

Sol: $\tan\theta = \frac{3}{4} \Rightarrow \sin\theta = \frac{3}{5}$

$\cos\theta = \frac{4}{5}$

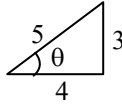

FBD for bar AB (2)

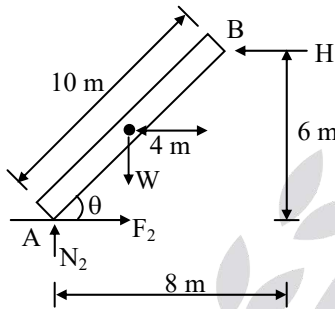

FBD for block (1)

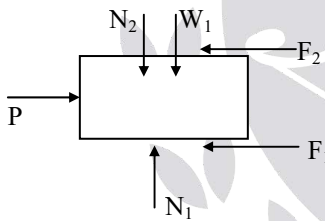

Given $W = 280 \text{ N}$, $W_1 = 400 \text{ N}$

Now, $\Sigma M_B = 0$

$-W \times 4 (\cup) + N_2 \times 8 (\cup) - F_2 \times 6 (\cup) = 0$

$-280 \times 4 + N_2 \times 8 - \mu N_2 \times 6 = 0$

$\Rightarrow N_2 = 200 \text{ N}$

But, $F_2 = \mu N_2 = 0.4 \times 200 = 80 \text{ N}$

From FBD of block (1)

$\Sigma F_y = 0$

$N_1 - N_2 - W_1 = 0$

$N_1 = N_2 + W_1$

$= 200 + 400$

$N_1 = 600 \text{ N}$

But, $F_1 = \mu N_1 = 0.4 \times 600$

$F_1 = 240 \text{ N}$

$\Sigma F_x = 0$

$P = F_1 + F_2 = 240 + 80$

$P = 320 \text{ N}$

06. Ans: (a)

Sol: Given, $W_A = 200 \text{ N}$, $\mu_A = 0.2$

$W_B = 300 \text{ N}$, $\mu_B = 0.5$

FBD for block 'B'.

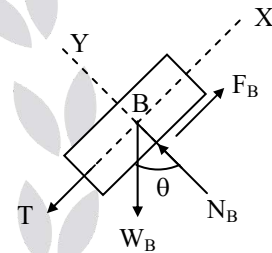

$\Sigma F_y = 0$

$N_B = W_B \cos\theta$

$N_B = 300 \cos\theta$

But, $F_B = \mu N_B = 0.5 \times 300 \cos\theta$
 $= 150 \cos\theta$

$\Sigma F_x = 0$

$T + W_B \sin\theta - F_B = 0$

$T = F_B - W_B \sin\theta$

$T = 150 \cos\theta - 300 \sin\theta$ ----- (1)

FBD for block 'A'

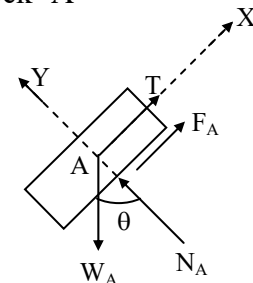

$$\Sigma F_y = 0$$

$$N_A - W_A \cos \theta = 0$$

$$N_A = 200 \cos \theta$$

$$F_A = \mu N_A = 0.2 \times 200 \cos \theta$$

$$\text{But, } F_A = 40 \cos \theta$$

$$\Sigma F_x = 0$$

$$T + F_A - W_A \sin \theta = 0$$

$$T = W_A \sin \theta - F_A$$

$$T = 200 \sin \theta - 40 \cos \theta$$

But from equation (1)

$$T = 150 \cos \theta - 300 \sin \theta$$

$$\therefore 150 \cos \theta - 300 \sin \theta = 200 \sin \theta - 40 \cos \theta$$

$$190 \cos \theta = 500 \sin \theta$$

$$\tan \theta = \frac{190}{500}$$

$$\Rightarrow \theta = 20.8^\circ$$

07. Ans: (d)

Sol: FBD for the block

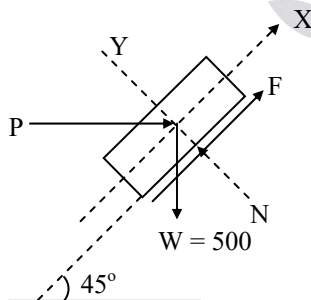

$$\Sigma F_y = 0$$

$$N - W \sin 45 - P \sin 45 = 0$$

$$N = \frac{500}{\sqrt{2}} + \frac{P}{\sqrt{2}}$$

$$\text{But, } F = \mu N = 0.25 \left(\frac{500}{\sqrt{2}} + \frac{P}{\sqrt{2}} \right)$$

$$\Sigma F_x = 0$$

$$P \cos 45 + F - W \sin 45 = 0$$

$$P \cos 45 + 0.25 \left(\frac{500}{\sqrt{2}} + \frac{P}{\sqrt{2}} \right) - 500 \times \frac{1}{\sqrt{2}} = 0$$

$$\Rightarrow P = 300 \text{ N}$$

08. Ans: (a)

Sol: FBD of block

$$F_1 = \mu N_1$$

$$F_2 = \mu N_2$$

$$\Sigma F_x = 0$$

$$N_2 - F_1 = 0$$

$$\Rightarrow N_2 = F_1 \quad (\because F_1 = \mu N_1)$$

$$N_2 = \mu N_1$$

$$\Sigma F_y = 0$$

$$N_1 + F_2 - W = 0$$

$$N_1 + \mu N_2 - W = 0$$

$$N_1 + \mu^2 N_1 - W = 0 \quad (\because N_2 = \mu N_1)$$

$$N_1 (1 + \mu^2) = W$$

$$N_1 = \frac{W}{1 + \mu^2}$$

$$N_2 = \frac{\mu W}{1 + \mu^2}$$

$$\text{Couple} = (F_1 + F_2) \times r$$

$$= \mu r (N_1 + N_2)$$

$$= \frac{\mu r \times W (1 + \mu)}{1 + \mu^2} \quad (\because \mu = f)$$

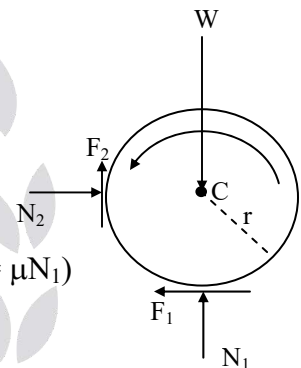

09. Ans: 64 N-m

Sol: FBD of shoe bar :

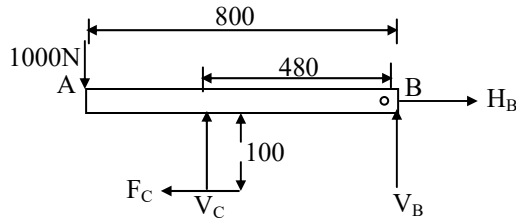

FBD of Drum Brake :

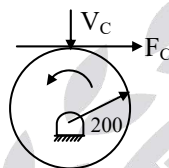

$$\sum M_B = 0$$

$$V_C \times 480 + F_C \times 100 - 1000 \times 800 = 0$$

$$F_C = \mu V_C = 0.2 V_C$$

$$480 V_C + 0.2 V_C \times 100 = 800000$$

$$500 V_C = 800000$$

$$V_C = 1600 \text{ N}$$

$$F_C = 0.2 V_C = 0.2 \times 1600 = 320 \text{ N}$$

$$M = 0.2 \times F_C = 0.2 \times 320 = 64 \text{ N-m}$$

10. Ans: (a)

Sol: $\beta = 2\theta$

$$\cos\theta = \frac{6}{12}$$

$$\Rightarrow \theta = 60$$

$$\beta = 360 - 2\theta$$

$$\beta = 240 = \frac{4\pi}{3}$$

$$2\alpha + 2\theta = 180$$

$$2\alpha = 180 - 120$$

$$\alpha = 30 = \frac{\pi}{6}$$

FBD

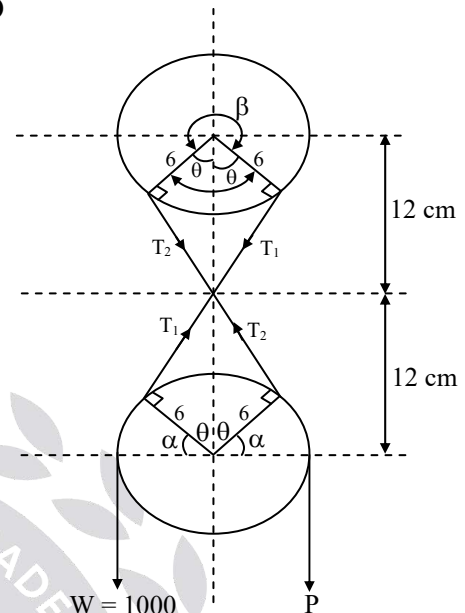

(When W moves upwards)

For P_{\min} calculation,

$$W > T_1$$

$$\frac{W}{T_1} = e^{\mu\alpha}$$

$$T_1 = \frac{1000}{e^{\frac{\pi}{6} \times \frac{1}{\pi}}} = 846.48 \text{ N}$$

$$\frac{T_1}{T_2} = e^{\mu\beta}$$

$$T_2 = \frac{846.48}{e^{\frac{1}{\pi} \times \frac{4\pi}{3}}} = 223.12 \text{ N}$$

$$\frac{T_2}{P_{\min}} = e^{\mu\alpha}$$

$$\Rightarrow P_{\min} = \frac{223.12}{e^{\frac{1}{\pi} \times \frac{\pi}{6}}}$$

$$P_{\min} = 188.86 \text{ N} \approx 189 \text{ N}$$

For P_{\max} calculation

$$\frac{T_1}{W} = e^{\mu\alpha}$$

$$T_1 = 1000 \times e^{\frac{1}{\pi} \times \frac{\pi}{6}}$$

$$T_1 = 1181.36 \text{ N}$$

$$\frac{T_2}{T_1} = e^{\mu\beta}$$

$$T_2 = 1181.36 \times e^{\frac{1}{\pi} \times \frac{4\pi}{3}} = 4481.65 \text{ N}$$

$$\frac{P_{\max}}{T_2} = e^{\mu\alpha}$$

$$P_{\max} = 4481.68 \times e^{\frac{1}{\pi} \times \frac{\pi}{6}}$$

$$P_{\max} = 5300 \text{ N}$$

11. Ans: (b)

Sol: Given $\mu = 0.2$, $\tan\theta = \frac{3}{4}$
 $\Rightarrow \cos\theta = \frac{4}{5}$
 $\sin\theta = \frac{3}{5}$

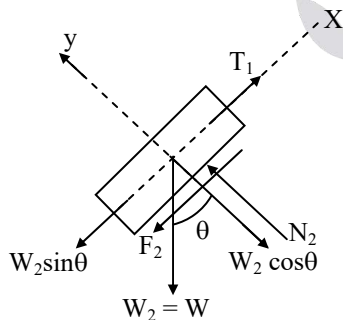

Fig: FBD (1)

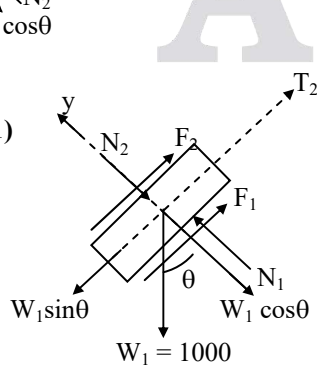

Fig: FBD (2)

From FBD (1)

$$\Sigma F_y = 0$$

$$N_2 - W_2 \cos\theta = 0$$

$$N_2 = W_2 \cos\theta = W \times 0.8$$

$$N_2 = 0.8 W$$

$$\therefore F_2 = \mu N_2 = 0.2 \times 0.8 W$$

$$F_2 = 0.16 W$$

$$\Sigma F_x = 0$$

$$T_1 - W_2 \sin\theta - F_2 = 0$$

$$T_1 = F_2 + W_2 \sin\theta = 0.16 W + 0.6 W$$

$$T_1 = 0.76 W$$

From FBD (2)

$$\Sigma F_y = 0$$

$$N_2 + W_1 \cos\theta = N_1$$

$$N_1 = N_2 + W_1 \cos\theta$$

$$N_1 = 0.8 W + 1000 \times \frac{4}{5}$$

$$N_1 = 0.8 W + 800$$

$$F_1 = \mu N_1 = 0.2 (0.8 W + 800)$$

$$= 0.16 W + 160$$

$$\frac{T_2}{T_1} = e^{\mu\beta}$$

$$T_2 = T_1 e^{\mu\beta} = 0.76 W e^{0.2 \times \pi}$$

$$T_2 = 1.42 W$$

$$\Sigma F_x = 0$$

$$T_2 + F_1 + F_2 = W_1 \sin\theta$$

$$1.42 W + 0.16 W + 160 + 0.16 W = 1000 \times \frac{3}{5}$$

$$1.74 W = 440$$

$$\Rightarrow W = 252.87 \text{ N}$$

12. Ans: (d)

Sol:

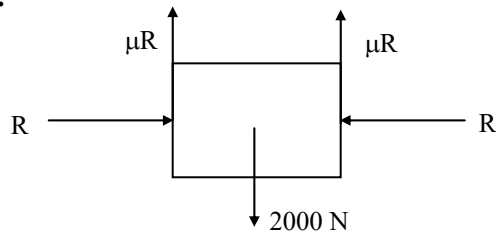

At equilibrium

$$2\mu R = 2000$$

$$\Rightarrow R = \frac{2000}{2 \times 0.1} = 10,000 \text{ N}$$

Taking moment about pin

$$10,000 \times 150 = F \times 300$$

$$\Rightarrow F = 5000 \text{ N}$$

13. Ans: (b)

Sol:

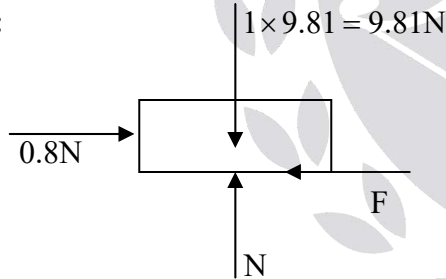

$$\Sigma Y = 0$$

$$\Rightarrow N = 9.81 \text{ N}$$

$$F_s = \mu N = 0.1 \times 9.81 = 0.98 \text{ N}$$

The External force applied = 0.8 N < F_s

\Rightarrow Frictional force = External applied
force = 0.8 N

14. Ans: (b)

Sol:

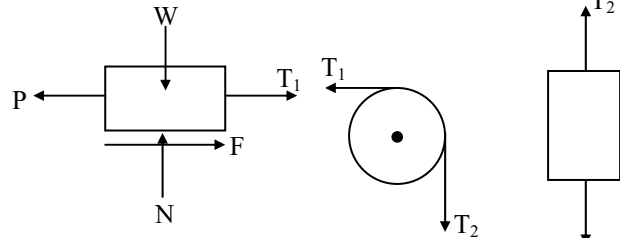

Fig: FBD (1)

Fig: FBD (2) Fig: FBD (3)

From FBD (3)

$$\Sigma F_y = 0$$

$$T_2 - 200 = 0$$

$$\Rightarrow T_2 = 200$$

From FBD (2)

$$\frac{T_1}{T_2} = e^{\mu\beta}$$

$$T_1 = T_2 e^{\mu\beta} = 200 \times e^{0.3 \times \frac{\pi}{2}}$$

$$T_1 = 320.39 \text{ N}$$

From FBD (1)

$$\Sigma F_y = 0$$

$$N - W = 0$$

$$N = 1000 \text{ N}$$

$$F = \mu N$$

$$= 0.3 \times 1000$$

$$F = 300 \text{ N}$$

$$\Sigma F_x = 0, T_1 + F - P = 0$$

$$320.39 + 300 = P$$

$$\Rightarrow P = 620.39$$

$$\Rightarrow P = 620.4 \text{ N}$$

Chapter

4

Free Vibrations of Undamped SDOF system
01. Ans: (b)

$$\text{Sol: } T = 2\pi\sqrt{\frac{L}{g}} \Rightarrow 0.5 = 2\pi \times \sqrt{\frac{L}{9.81}}$$

$$\Rightarrow L = 62.12 \text{ mm}$$

02. Ans: (c)

Sol: Let, V_0 is the initial velocity,
'm' is the mass

Equating Impulse = momentum

$$mV_0 = 5\text{kN} \times 10^{-4} \text{ sec}$$

$$= 5 \times 10^3 \times 10^{-4} = 0.5 \text{ sec}$$

$$\therefore V_0 = \frac{0.5}{m} = 0.5 \text{ m/sec}$$

$$\omega_n = \sqrt{\frac{k}{m}} = \sqrt{\frac{10000}{1}} = 100 \text{ rad/sec}$$

When the free vibrations are initiated with initial velocity,

The amplitude

$$X = \frac{V_0}{\omega_n} \text{ (Initial displacement)}$$

$$\therefore X = \frac{V_0}{\omega_n} = \frac{0.5 \times 10^3}{100} = 5 \text{ mm}$$

03. Ans: (a)

Sol: Note: ω_n depends on mass of the system not on gravity

$$\therefore \omega_n \propto \frac{1}{\sqrt{m}}$$

$$\text{If } \omega_n = \sqrt{\frac{g}{\delta}}, \quad \delta = \frac{mg}{K}$$

$$\therefore \omega_n = \sqrt{\frac{g}{\left(\frac{mg}{K}\right)}} = \sqrt{\frac{K}{m}}$$

$\therefore \omega_n$ is constant every where.

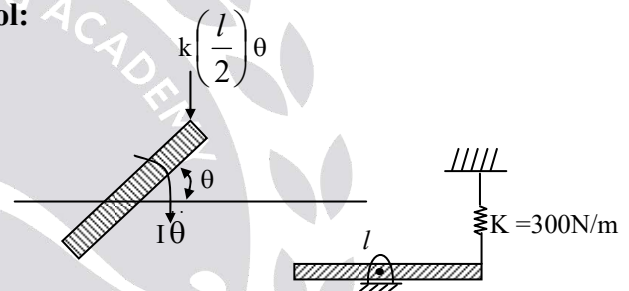
04. Ans: (c)
Sol:

By energy method

$$E = \frac{1}{2} I \dot{\theta}^2 + \frac{1}{2} K x^2 = \text{constant}$$

$$E = \frac{1}{2} I \dot{\theta}^2 + \frac{1}{2} K \times \left(\frac{l}{2} \theta\right)^2 = \text{constant}$$

Differentiating w.r.t 't'

$$\frac{dE}{dt} = I \ddot{\theta} + \frac{K}{2} \times \frac{l^2}{4} \times 2\theta = 0$$

$$I = \frac{m l^2}{12}$$

$$\frac{m l^2}{12} \ddot{\theta} + \frac{K l^2}{4} \theta = 0$$

$$\Rightarrow \ddot{\theta} + \frac{3K}{m} \theta = 0$$

$$\Rightarrow \omega_n = \sqrt{\frac{3K}{m}} = 30 \text{ rad/sec}$$

05. Ans: (a)

06. Ans: (d)

Sol: $X_0 = 10 \text{ cm}$, $\omega_n = 5 \text{ rad/sec}$

$$X = \sqrt{x_0^2 + \left(\frac{v_0}{\omega_n}\right)^2}$$

If $v_0 = 0$ then $X = x_0$

$$\therefore X = x_0 = 10 \text{ cm}$$

07. Ans: 0.0658 N.m²

Sol: For a Cantilever beam stiffness, $K = \frac{3EI}{l^3}$

$$\text{Natural frequency, } \omega_n = \sqrt{\frac{K}{m}} = \sqrt{\frac{3EI}{m l^3}}$$

Given $f_n = 100 \text{ Hz}$

$$\Rightarrow \omega_n = 2\pi f_n = 200\pi$$

$$200\pi = \sqrt{\frac{3EI}{m l^3}}$$

Flexural Rigidity

$$EI = \frac{(200\pi)^2 \cdot m l^3}{3} = 0.0658 \text{ N.m}^2$$

08. Ans: (a)

Sol:

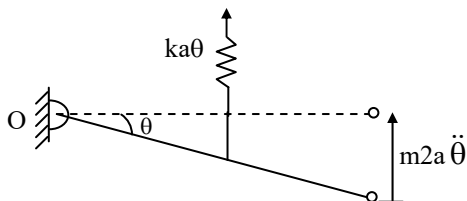

By taking the moment about 'O', $\Sigma m_o = 0$

$$(m2a\ddot{\theta} \times 2a) + (ka\theta \times a) = 0$$

$$\Rightarrow 4a^2 m \ddot{\theta} + ka^2 \theta = 0$$

Where, $m_{eq} = 4a^2 m$, $k_{eq} = ka^2$

Natural frequency, $\omega_n = \sqrt{\frac{k_{eq}}{m_{eq}}}$

$$= \sqrt{\frac{ka^2}{4a^2 m}} = \sqrt{\frac{k}{4m}} \text{ rad/sec}$$

$$[\because \omega_n = 2\pi f]$$

$$\Rightarrow f = \frac{\omega_n}{2\pi} = \frac{1}{2\pi} \times \sqrt{\frac{k}{4m}} \text{ Hz}$$

09. Ans: 10

Sol: Given Data:

$$m = 10 \text{ kg}$$

$$K = 4\pi^2 \times 10^3$$

\Rightarrow Natural frequency

$$f_n = \frac{1}{2\pi} \sqrt{\frac{k}{m}}$$

$$= \frac{1}{2\pi} \sqrt{\frac{4\pi^2 \times 10^3}{10}}$$

$$= \frac{2\pi \times 10}{2\pi} = 10$$

10. Ans: (a)

Sol:

$$1. \quad \delta = \frac{PL^3}{12EI}$$

$$\therefore \text{Stiffness of bar, } K = \frac{P}{\delta} = \frac{12EI}{L^3}$$

2. Equivalent stiffness k_e ,
The bars are in parallel arrangement

$$\therefore k_e = k + k + k = \frac{36EI}{L^3}$$

3. Natural Frequency ω_n ,

$$\begin{aligned} \omega_n &= \sqrt{\frac{k_e}{m}} \text{ rad/sec} \\ &= \sqrt{\frac{36EI}{mL^3}} = 6\sqrt{\frac{EI}{mL^3}} \text{ rad/sec} \end{aligned}$$

11. Ans: (d)

Sol:

Beam and spring are parallel

$$w_n = \sqrt{\frac{K}{M}}$$

$$K_e = K_1 + K_2$$

$$K_1 = \frac{3EI}{\ell^3}, K_2 = K$$

$$w_n = \sqrt{\frac{\frac{3EI}{\ell^3} + K}{m}}$$

$$W_n = \sqrt{\frac{3EI + K\ell^3}{m}}$$

12. Ans: (a)

Sol: Beam and spring are in series

$$K_e = \frac{K_1 K_2}{K_1 + K_2}$$

$$K_2 = \frac{192EI}{\ell^3}, K_1 = K_1$$

$$w_n = \sqrt{\frac{K_e}{M}}$$

$$= \left(\frac{K_1 K_2}{M(K_1 + K_2)} \right)^{\frac{1}{2}}$$

13. Ans: (d)

Sol: $k_{eq} = k_1 + k_2 + k_3$

$$= \frac{12EI_c}{h^3} + \frac{12EI_c}{h^3} + \frac{12EI_c}{h^3}$$

$$k_{eq} = \frac{36EI_c}{h^3}$$

$$w_n = \sqrt{\frac{k_{eq}}{m}} = \sqrt{\frac{27EI_c}{h^3}}$$

$$w_n = \sqrt{\frac{27 EI_c}{h^3 m}}$$

14. Ans: (c)

Sol: $k_{eq} = \frac{24EI_c}{h^3}$ ← as per formula when both

have EI_c

$$\begin{aligned} \therefore k_{eq} &= k_1 + k_2 \\ &= \frac{12EI_c}{h^3} + \frac{12(2EI_c)}{h^3} \\ &= \frac{36EI_c}{h^3} \end{aligned}$$

15. Ans: (d)

Sol:

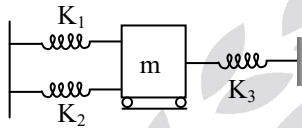

$$\begin{aligned} m &= 4 \text{ kg}, & K_1 &= 100 \text{ w/m} \\ K_2 &= 200 \text{ N/m} & K_3 &= 100 \text{ N/m} \\ K_e &= (K_1 + K_2) + K_3 = 400 \text{ N/m} \end{aligned}$$

$$T = \frac{2\pi}{\omega} = 2\pi \sqrt{\frac{M}{K}} = 2\pi \sqrt{\frac{4}{400}} = \frac{2\pi}{10}$$

$$T = 0.628 \text{ seconds}$$

16. Ans: (a)

$$\text{Sol: } p = \frac{\frac{EI_b}{L}}{2 \times \left[\frac{EI_c}{h} \right]} = \frac{\frac{EI_c}{2(2h)}}{2 \left[\frac{EI_c}{h} \right]} = \frac{1}{8}$$

$$k_{eq} = \frac{24EI_c}{h^3} \left[\frac{12 \left(\frac{1}{8} \right) + 1}{12 \left(\frac{1}{8} \right) + 4} \right]$$

$$k_{eq} = \frac{24EI_c}{h^3} \left[\frac{12 + 8}{12 + 32} \right]$$

$$k_{eq} = \frac{24EI_c}{h^3} \left[\frac{20}{44} \right]$$

$$k_{eq} = \sqrt{\frac{12EI_c}{11mh^3}}$$

17. Ans: (a)

Sol: Given:

Initial	Final
Mass = m	Mass = m/2
Stiffness = k	Stiffness = 2k
ω	$\omega_{final} = ?$
T	$T_{final} = ?$

$$\text{Natural frequency of spring} = \sqrt{\frac{k}{m}} = \omega$$

$$\text{In final condition} = \omega_{final} = \sqrt{\frac{2k}{m/2}}$$

$$= \sqrt{\frac{4k}{m}} = 2\sqrt{\frac{k}{m}} = 2\omega$$

$$T = \frac{2\pi}{\omega}; T_{final} = \frac{2\pi}{2\omega} = \frac{1}{2} = \frac{2\pi}{\omega} = \frac{1}{2}T$$

$$\therefore 2\omega \text{ rad/s \& } \frac{T}{2}$$

Engineering Mechanics

(Solutions for Text Book Practice Questions)

Chapter

1

Force and Moment Systems

01. Ans: (b)

Sol:

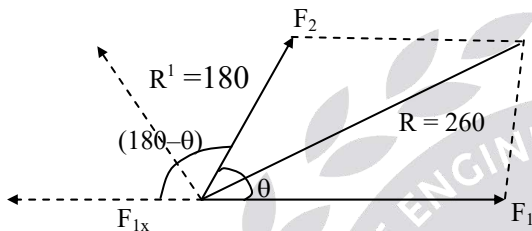

Assume $F_1 = 2F_2$ ($F_1 > F_2$)

$$F_{1x} = 2F_2$$

$$R = \sqrt{F_1^2 + F_2^2 + 4F_2^2 \cos \theta}$$

$$260 = \sqrt{4F_2^2 + F_2^2 + 4F_2^2 \cos \theta}$$

$$260^2 = 5F_2^2 + 4F_2^2 \cos \theta \quad \text{----- (1)}$$

$$R^1 = \sqrt{F_{1x}^2 + F_2^2 + 2F_{1x}F_2 \cos \theta}$$

$$180 = \sqrt{4F_2^2 + F_2^2 + 2F_2 \cdot F_2 \cos(180 - \theta)}$$

$$180^2 = 5F_2^2 - 4F_2^2 \cos \theta \quad \text{----- (2)}$$

$$260^2 = 5F_2^2 + 4F_2^2 \cos \theta$$

$$180^2 = 5F_2^2 - 4F_2^2 \cos \theta$$

$$260^2 + 180^2 = 10F_2^2$$

$$\Rightarrow F_2 = 100\text{N},$$

$$260^2 = 5(100)^2 + 4(100)^2 \cos \theta$$

$$\Rightarrow \theta = 63.89^\circ$$

Where θ angle between two forces.

02. Ans: (b)

Sol: Let the angle between the forces be θ

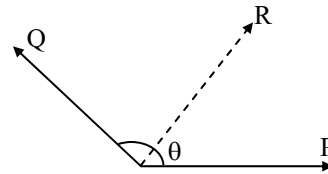

Where, R is the resultant of the two forces.

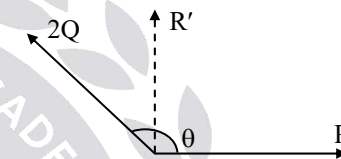

If Q is doubled i.e., $2Q$ then resultant (R') is perpendicular to P.

$$\tan 90 = \frac{2Q \sin \theta}{P + 2Q \cos \theta}$$

$$\Rightarrow P + 2Q \cos \theta = 0$$

$$P = -2Q \cos \theta \quad \text{----- (i)}$$

$$\text{Also, } R = \sqrt{P^2 + Q^2 + 2PQ \cos \theta}$$

$$R = Q \text{ [using eq.(i)]}$$

03. Ans: (b)

Sol: Since moment of F about point A is zero.

\therefore F passes through point A,

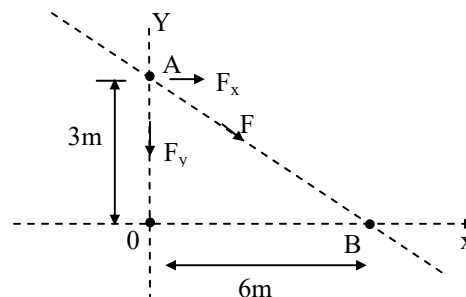

$$M_0^F = 180\text{N} - m$$

$$M_B^F = 90\text{N} - m$$

$$M_A^F = 0$$

$$M_0^F = 180 = F_x \times 3 + F_y \times 0$$

$$F_x = 60\text{N} \dots\dots (1)$$

$$M_B^F = F_x \times 3 - F_y \times 6 = -90$$

$$60 \times 3 - 6F_y = -90$$

$$\Rightarrow F_y = \frac{270}{6}$$

$$F_y = 45\text{N}$$

$$\therefore F = \sqrt{F_x^2 + F_y^2} = \sqrt{60^2 + 45^2} = 75\text{N}$$

04. Ans: (a)

Sol:

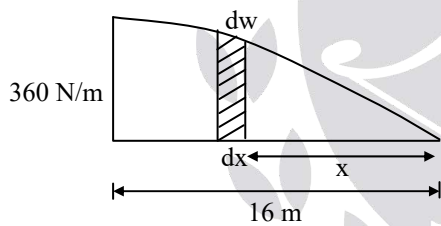

$$\int_0^w dw = \int_0^{16} w dx$$

$$w = \int_0^{16} 90\sqrt{x} dx = 90 \left[\frac{x^{\frac{1}{2}+1}}{\frac{1}{2}+1} \right]_0^{16}$$

$$= 90 \times \frac{2}{3} \left[x^{3/2} \right]_0^{16} = 60 (16)^{3/2}$$

$$w = 3840\text{N}$$

The moment due to average force should be equal to the variable force

$$R \times d = \Sigma dw \times x$$

$$3840 \times d = \int_0^{16} 90\sqrt{x} \cdot dx \cdot x$$

$$= 90 \int_0^{16} x^{1.5} dx$$

$$3840d = 90 \left[\frac{x^{2.5}}{2.5} \right]_0^{16}$$

$$\Rightarrow d = 9.6\text{m}$$

05. Ans: (c)

Sol: Moment about 'O'

$$M_0 = 100 \sin 60 \times 3$$

$$= 300 \times \frac{\sqrt{3}}{2} = 150\sqrt{3}$$

$$= 259.8 \approx 260\text{N}$$

06. Ans: (a)

Sol:

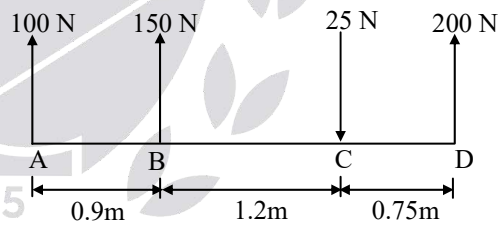

$$F_R = \Sigma F_y$$

$$F_R = 100 + 150 - 25 + 200 \text{ (upward force positive and downward force negative)}$$

$$R = 425\text{N}$$

For equilibrium

$$\Sigma M_A = 0 \text{ (since } R = \text{resultant)}$$

Let R is acting at a distance of 'd'

$$425 \times d = 150 \times 0.9 + 25 \times 2.1 - 200 \times 2.85$$

$$\Rightarrow d = 1.535\text{m (from A)}$$

Chapter

2

Equilibrium of Force System

01. Ans: (d)

Sol:

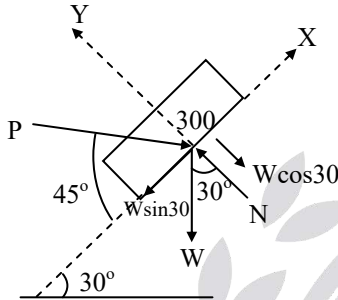

Resolve the forces along the inclined surface

$$\sum F_x = 0$$

$$P \cos 45 - W \sin 30 = 0$$

$$P = \frac{300 \sin 30}{\cos 45} \Rightarrow P = 212.13 \text{ N}$$

02. Ans: (a)

Sol:

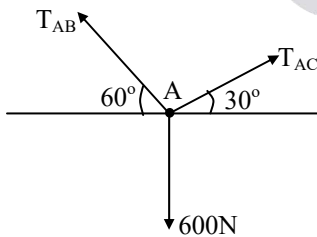

$$T_{AB} \cos 60^\circ = T_{AC} \cos 30^\circ$$

$$T_{AB} = \sqrt{3} T_{AC}$$

$$T_{AB} \sin 60^\circ + T_{AC} \sin 30^\circ = 600 \text{ N}$$

$$\frac{3}{2} T_{AC} + \frac{1}{2} T_{AC} = 600$$

$$\Rightarrow T_{AB} = 520 \text{ N}; \quad T_{AC} = 300 \text{ N}$$

03. Ans: (c)

Sol:

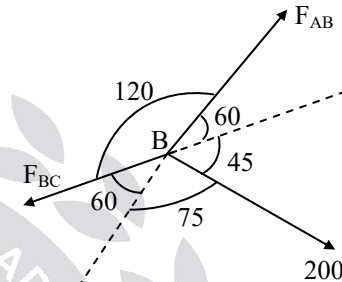
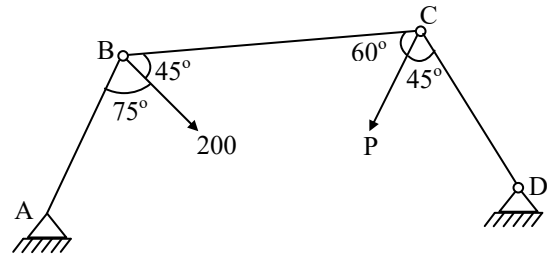

Fig: Free body diagram at 'B'

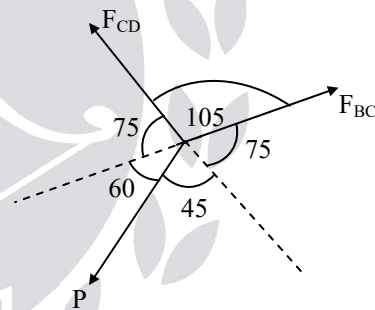

Fig: Free body diagram at 'C'

For Equilibrium of Point 'B'

$$\frac{F_{AB}}{\sin(60 + 75)} = \frac{F_{BC}}{\sin(60 + 45)} = \frac{200}{\sin(120)}$$

$$F_{BC} = 223.07 \text{ N}$$

From Sine rule at "C".

$$\frac{F_{CD}}{\sin(75 + 45)} = \frac{F_{BC}}{\sin(60 + 75)} = \frac{P}{\sin 105}$$

$$P = \frac{223.07 \times \sin 105}{\sin 135}$$

$$P = 304.71 \text{ N}$$

04. Ans: (d)

Sol:

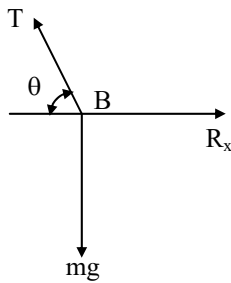

$$\tan\theta = \frac{125}{275} \Rightarrow \theta = 24.45^\circ$$

$$T \sin\theta = mg$$

$$T \sin 24.45 = (35 \times 9.81)$$

$$T = 829.5 \text{ N}$$

$$R_x = T \cos 24.45 = 755.4 \text{ N}$$

$$R_y = 0$$

05. Ans: (c)

Sol:

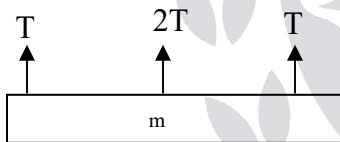

$$T + 2T + T = mg$$

$$4T = mg$$

$$m = 4T/g$$

06. Ans: (b)

Sol:

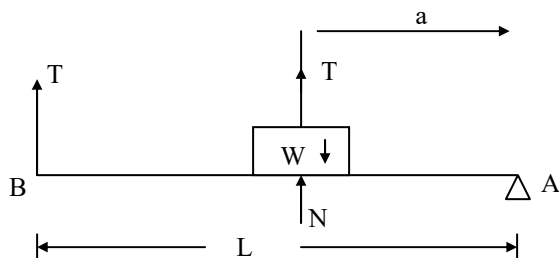

For body, $\Sigma F_y = 0$

$$N - W + T = 0$$

$$\Rightarrow N = W - T$$

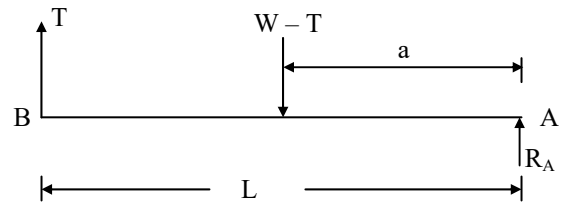

$\Sigma F_y = 0$ for entire system

$$R_A + T - (W - T) = 0$$

$$R_A = W - 2T \quad \text{----- (1)}$$

For equilibrium

$$\Sigma M_A = 0$$

$$T \times L = (W - T) a$$

$$TL = Wa - Ta$$

$$TL + Ta = Wa$$

$$T(L + a) = Wa$$

$$\Rightarrow T = \frac{Wa}{L + a}$$

T substitute in equation (1)

$$R_A = W - 2\left(\frac{Wa}{L + a}\right)$$

$$= \frac{W(L + a) - 2Wa}{L + a}$$

$$= \frac{WL + Wa - 2Wa}{L + a}$$

$$= \frac{WL - Wa}{L + a}$$

$$R_A = \frac{W(L - a)}{L + a}$$

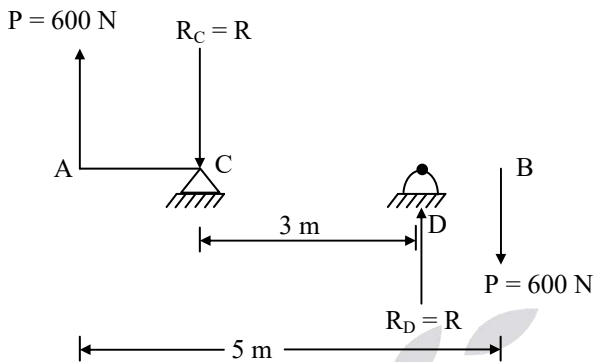
07. Ans: (c)
Sol:

$$\sum F_y = 0$$

$$600 - R_C + R_D - 600 = 0$$

$$\Rightarrow R_C = R_D = R$$

$$\sum M = 0$$

$$600 \times 5 = R \times 3$$

$$\Rightarrow R = 1000 \text{ N} = R_C = R_D$$

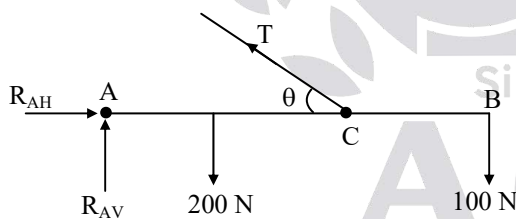
08. Ans: (a)
Sol: F.B.D

$$\sum M_A = 0$$

$$\tan \theta = \frac{8}{4}$$

$$\theta = 63.43$$

$$T \sin \theta \times 4 (\cup) - 200 \times 2 (\cup) - 100 \times 6 (\cup) = 0$$

$$\Rightarrow T = 279.5 \text{ N}$$

$$\text{Now, } \sum F_x = 0,$$

$$R_{AH} - T \cos \theta = 0$$

$$R_{AH} = 125 \text{ N}$$

$$\sum F_y = 0$$

$$R_{AV} - 200 - 100 + T \sin \theta = 0$$

$$\Rightarrow R_{VA} = 50 \text{ N}$$

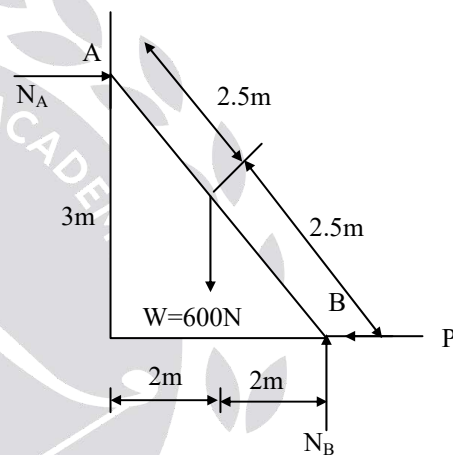
09. Ans: 400 N
Sol:

$$\sum F_y = 0$$

$$N_B - W = 0$$

$$N_B = 600 \text{ N}$$

$$\sum M_A = 0$$

$$P \times 3 + W \times 2 - N_B \times 4 = 0$$

$$P = \frac{4N_B - 2W}{3}$$

$$P = \frac{4 \times 600 - 2 \times 600}{3} = 400 \text{ N}$$

Chapter 3

Friction

01. Ans: (c)

Sol: The FBD of the above block shown

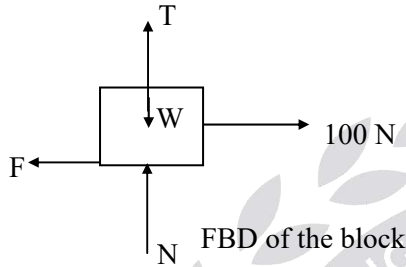

$$\Sigma Y = 0 \Rightarrow N + T - W = 0$$

$$N = W - T = 981 - T$$

$$F = \mu N = 0.2(981 - T)$$

$$\Sigma X = 0 \Rightarrow 100 - F = 0$$

$$F = 100 = 0.2(981 - T)$$

$$\Rightarrow T = 481 \text{ N}$$

02. Ans: (c)

Sol: Given $\tan \theta = \frac{3}{4}$

$$\sin \theta = \frac{3}{5}$$

$$\cos \theta = \frac{4}{5}$$

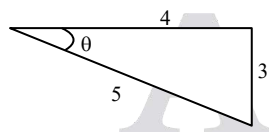

Free body diagram for block (2)

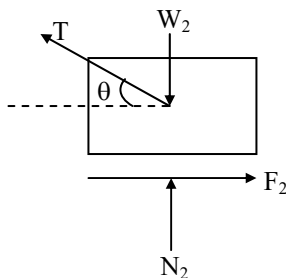

Free body diagram for block (1)

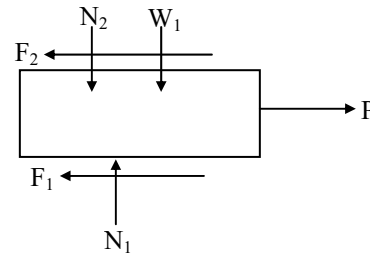

From FBD of block (2)

$$\Sigma F_x = 0$$

$$F_2 = T \cos \theta$$

$$F_2 = \frac{4}{5} T = 0.8T \text{ ----- (1)}$$

$$\Sigma F_y = 0$$

$$N_2 + T \sin \theta - W_2 = 0$$

$$N_2 = W_2 - T \sin \theta$$

$$N_2 = 50 - 0.6T$$

$$\text{But } F_2 = \mu N_2$$

$$\Rightarrow F_2 = 0.3(50 - 0.6T)$$

$$F_2 = 15 - 0.18T \text{ ----- (2)}$$

From (1) & (2)

$$0.8T = 15 - 0.18T$$

$$\Rightarrow 0.98T = 15$$

$$\Rightarrow T = 15.31 \text{ N}$$

$$\therefore N_2 = 50 - 0.6T$$

$$= 50 - 0.6(15.31) = 40.81 \text{ N}$$

$$F_2 = \mu N_2 = 0.3 \times 40.81 = 12.24 \text{ N}$$

From FBD of block (1)

$$\Sigma F_y = 0$$

$$N_1 - N_2 - W_1 = 0$$

$$N_1 = N_2 + W_1 = 40.81 + 200 = 240.81 \text{ N}$$

$$F_1 = \mu N_1 \Rightarrow F_1 = 0.3 \times 240.81$$

$$F_1 = 72.24 \text{ N}$$

$$\Sigma F_x = 0$$

$$P - F_1 - F_2 = 0$$

$$P = F_1 + F_2 = 72.24 + 12.24$$

$$P = 84.48 \text{ N}$$

03. Ans: (b)

Sol: Free Body Diagram

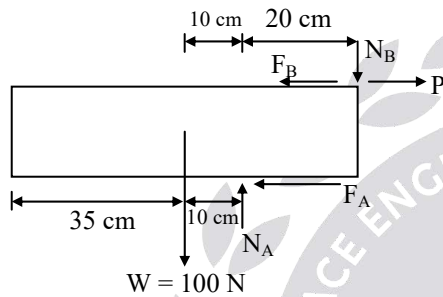

$$F_A = \mu N_A = \frac{1}{3} N_A$$

$$F_B = \mu N_B = \frac{1}{3} N_B$$

$$\Sigma M_B = 0$$

$$-100 \times 30 (\cup) + (N_A \times 20) (\cup) + (F_A \times 12) (\cup) = 0$$

$$-3000 + N_A \times 20 + \frac{1}{3} N_A \times 12 = 0$$

$$\Rightarrow N_A = 125 \text{ N}$$

$$\Sigma F_y = 0$$

$$N_A - N_B - 100 = 0$$

$$\Rightarrow N_B = 25 \text{ N}$$

$$\Sigma F_x = 0$$

$$P = F_A + F_B = \frac{1}{3} (N_A + N_B)$$

$$= \frac{1}{3} (125 + 25) = 50 \text{ N}$$

04. Ans: (d)

Sol: F.B.D of both the books are shown below.

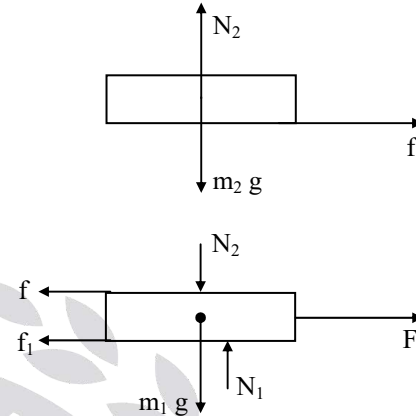

where, f is the friction between the two books.

f_1 is the friction between the lower book and ground.

Now, maximum possible acceleration of upper book.

$$a_{\max} = \frac{f_{\max}}{m_2} = \frac{\mu m_2 g}{m_2} = \mu \times g$$

$$= 0.3 \times 9.81 = 2.943 \text{ m/s}^2$$

For slip to occur, acceleration (a_1) of lower book. i.e., $a_1 \geq a_{\max}$

$$\frac{F - f - f_1}{m_1} \geq 2.943$$

$$F - 2.943 - 0.3 \times 2 \times 9.81 \geq 2.943$$

$$[\because f = f_{\max} = 2.943 \text{ and}$$

$$f_1 = \mu \times (m_1 + m_2) g = 0.3 \times 2 \times 9.81]$$

$$F \geq 11.77 \text{ N}$$

$$F_{\min} = 11.77 \text{ N}$$

05. Ans: (d)

Sol: $\tan\theta = \frac{3}{4} \Rightarrow \sin\theta = \frac{3}{5}$

$\cos\theta = \frac{4}{5}$

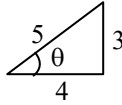

FBD for bar AB (2)

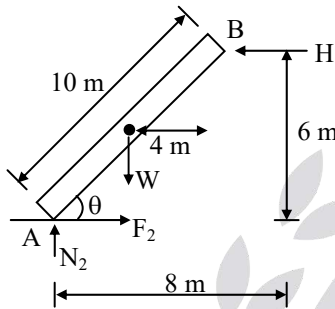

FBD for block (1)

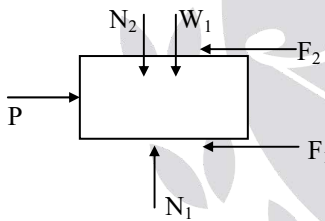

Given $W = 280 \text{ N}$, $W_1 = 400 \text{ N}$

Now, $\Sigma M_B = 0$

$-W \times 4 (\cup) + N_2 \times 8 (\cup) - F_2 \times 6 (\cup) = 0$

$-280 \times 4 + N_2 \times 8 - \mu N_2 \times 6 = 0$

$\Rightarrow N_2 = 200 \text{ N}$

But, $F_2 = \mu N_2 = 0.4 \times 200 = 80 \text{ N}$

From FBD of block (1)

$\Sigma F_y = 0$

$N_1 - N_2 - W_1 = 0$

$N_1 = N_2 + W_1$
 $= 200 + 400$

$N_1 = 600 \text{ N}$

But, $F_1 = \mu N_1 = 0.4 \times 600$

$F_1 = 240 \text{ N}$

$\Sigma F_x = 0$

$P = F_1 + F_2 = 240 + 80$

$P = 320 \text{ N}$

06. Ans: (a)

Sol: Given, $W_A = 200 \text{ N}$, $\mu_A = 0.2$

$W_B = 300 \text{ N}$, $\mu_B = 0.5$

FBD for block 'B'.

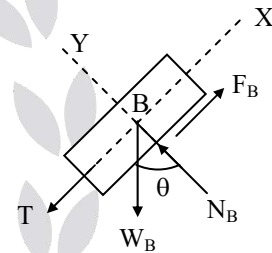

$\Sigma F_y = 0$

$N_B = W_B \cos\theta$

$N_B = 300 \cos\theta$

But, $F_B = \mu N_B = 0.5 \times 300 \cos\theta$
 $= 150 \cos\theta$

$\Sigma F_x = 0$

$T + W_B \sin\theta - F_B = 0$

$T = F_B - W_B \sin\theta$

$T = 150 \cos\theta - 300 \sin\theta$ ----- (1)

FBD for block 'A'

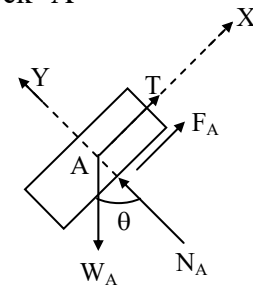

$$\Sigma F_y = 0$$

$$N_A - W_A \cos \theta = 0$$

$$N_A = 200 \cos \theta$$

$$F_A = \mu N_A = 0.2 \times 200 \cos \theta$$

$$\text{But, } F_A = 40 \cos \theta$$

$$\Sigma F_x = 0$$

$$T + F_A - W_A \sin \theta = 0$$

$$T = W_A \sin \theta - F_A$$

$$T = 200 \sin \theta - 40 \cos \theta$$

But from equation (1)

$$T = 150 \cos \theta - 300 \sin \theta$$

$$\therefore 150 \cos \theta - 300 \sin \theta = 200 \sin \theta - 40 \cos \theta$$

$$190 \cos \theta = 500 \sin \theta$$

$$\tan \theta = \frac{190}{500}$$

$$\Rightarrow \theta = 20.8^\circ$$

07. Ans: (d)

Sol: FBD for the block

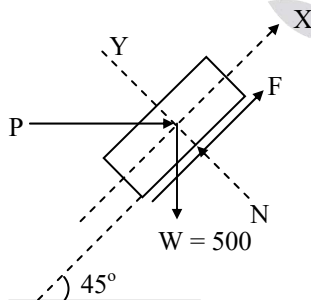

$$\Sigma F_y = 0$$

$$N - W \sin 45 - P \sin 45 = 0$$

$$N = \frac{500}{\sqrt{2}} + \frac{P}{\sqrt{2}}$$

$$\text{But, } F = \mu N = 0.25 \left(\frac{500}{\sqrt{2}} + \frac{P}{\sqrt{2}} \right)$$

$$\Sigma F_x = 0$$

$$P \cos 45 + F - W \sin 45 = 0$$

$$P \cos 45 + 0.25 \left(\frac{500}{\sqrt{2}} + \frac{P}{\sqrt{2}} \right) - 500 \times \frac{1}{\sqrt{2}} = 0$$

$$\Rightarrow P = 300 \text{ N}$$

08. Ans: (a)

Sol: FBD of block

$$F_1 = \mu N_1$$

$$F_2 = \mu N_2$$

$$\Sigma F_x = 0$$

$$N_2 - F_1 = 0$$

$$\Rightarrow N_2 = F_1 \quad (\because F_1 = \mu N_1)$$

$$N_2 = \mu N_1$$

$$\Sigma F_y = 0$$

$$N_1 + F_2 - W = 0$$

$$N_1 + \mu N_2 - W = 0$$

$$N_1 + \mu^2 N_1 - W = 0 \quad (\because N_2 = \mu N_1)$$

$$N_1 (1 + \mu^2) = W$$

$$N_1 = \frac{W}{1 + \mu^2}$$

$$N_2 = \frac{\mu W}{1 + \mu^2}$$

$$\text{Couple} = (F_1 + F_2) \times r$$

$$= \mu r (N_1 + N_2)$$

$$= \frac{\mu r \times W (1 + \mu)}{1 + \mu^2} \quad (\because \mu = f)$$

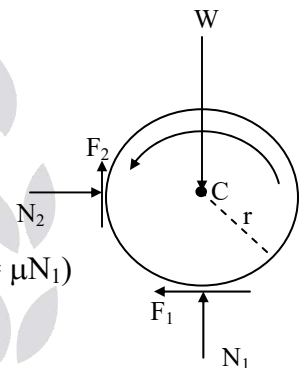

09. Ans: 64 N-m

Sol: FBD of shoe bar :

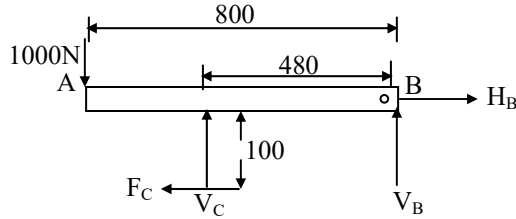

FBD of Drum Brake :

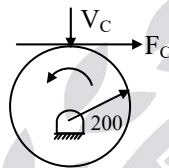

$$\sum M_B = 0$$

$$V_C \times 480 + F_C \times 100 - 1000 \times 800 = 0$$

$$F_C = \mu V_C = 0.2 V_C$$

$$480 V_C + 0.2 V_C \times 100 = 800000$$

$$500 V_C = 800000$$

$$V_C = 1600 \text{ N}$$

$$F_C = 0.2 V_C = 0.2 \times 1600 = 320 \text{ N}$$

$$M = 0.2 \times F_C = 0.2 \times 320 = 64 \text{ N-m}$$

10. Ans: (a)

Sol: $\beta = 2\theta$

$$\cos\theta = \frac{6}{12}$$

$$\Rightarrow \theta = 60$$

$$\beta = 360 - 2\theta$$

$$\beta = 240 = \frac{4\pi}{3}$$

$$2\alpha + 2\theta = 180$$

$$2\alpha = 180 - 120$$

$$\alpha = 30 = \frac{\pi}{6}$$

FBD

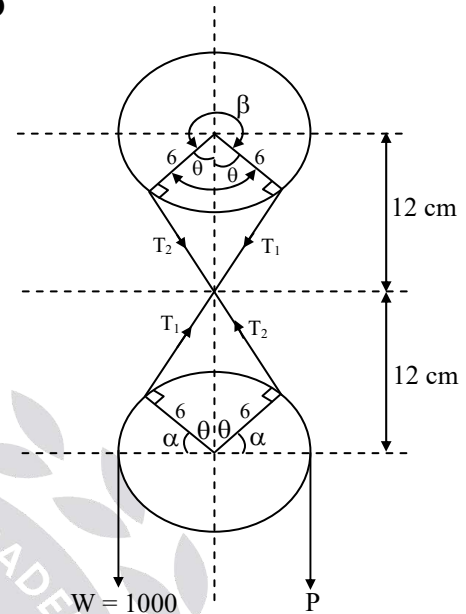

(When W moves upwards)

For P_{\min} calculation,

$$W > T_1$$

$$\frac{W}{T_1} = e^{\mu\alpha}$$

$$T_1 = \frac{1000}{e^{\frac{\pi}{6} \times \frac{1}{\pi}}} = 846.48 \text{ N}$$

$$\frac{T_1}{T_2} = e^{\mu\beta}$$

$$T_2 = \frac{846.48}{e^{\frac{1}{\pi} \times \frac{4\pi}{3}}} = 223.12 \text{ N}$$

$$\frac{T_2}{P_{\min}} = e^{\mu\alpha}$$

$$\Rightarrow P_{\min} = \frac{223.12}{e^{\frac{1}{\pi} \times \frac{\pi}{6}}}$$

$$P_{\min} = 188.86 \text{ N} \approx 189 \text{ N}$$

For P_{\max} calculation

$$\frac{T_1}{W} = e^{\mu\alpha}$$

$$T_1 = 1000 \times e^{\frac{1}{\pi} \times \frac{\pi}{6}}$$

$$T_1 = 1181.36 \text{ N}$$

$$\frac{T_2}{T_1} = e^{\mu\beta}$$

$$T_2 = 1181.36 \times e^{\frac{1}{\pi} \times \frac{4\pi}{3}} = 4481.65 \text{ N}$$

$$\frac{P_{\max}}{T_2} = e^{\mu\alpha}$$

$$P_{\max} = 4481.68 \times e^{\frac{1}{\pi} \times \frac{\pi}{6}}$$

$$P_{\max} = 5300 \text{ N}$$

11. Ans: (b)

Sol: Given $\mu = 0.2$, $\tan\theta = \frac{3}{4}$

$$\Rightarrow \cos\theta = \frac{4}{5}$$

$$\sin\theta = \frac{3}{5}$$

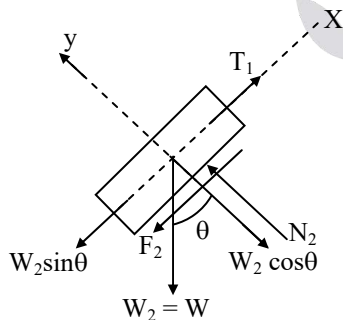

Fig: FBD (1)

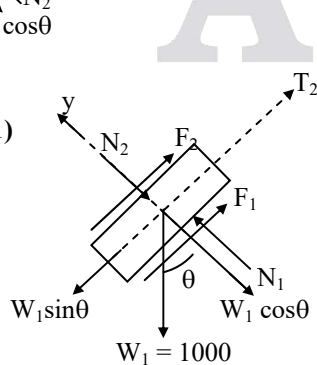

Fig: FBD (2)

From FBD (1)

$$\Sigma F_y = 0$$

$$N_2 - W_2 \cos\theta = 0$$

$$N_2 = W_2 \cos\theta = W \times 0.8$$

$$N_2 = 0.8 W$$

$$\therefore F_2 = \mu N_2 = 0.2 \times 0.8 W$$

$$F_2 = 0.16 W$$

$$\Sigma F_x = 0$$

$$T_1 - W_2 \sin\theta - F_2 = 0$$

$$T_1 = F_2 + W_2 \sin\theta = 0.16 W + 0.6 W$$

$$T_1 = 0.76 W$$

From FBD (2)

$$\Sigma F_y = 0$$

$$N_2 + W_1 \cos\theta = N_1$$

$$N_1 = N_2 + W_1 \cos\theta$$

$$N_1 = 0.8 W + 1000 \times \frac{4}{5}$$

$$N_1 = 0.8 W + 800$$

$$F_1 = \mu N_1 = 0.2 (0.8 W + 800) \\ = 0.16 W + 160$$

$$\frac{T_2}{T_1} = e^{\mu\beta}$$

$$T_2 = T_1 e^{\mu\beta} = 0.76 W e^{0.2 \times \pi}$$

$$T_2 = 1.42 W$$

$$\Sigma F_x = 0$$

$$T_2 + F_1 + F_2 = W_1 \sin\theta$$

$$1.42 W + 0.16 W + 160 + 0.16 W = 1000 \times \frac{3}{5}$$

$$1.74 W = 440$$

$$\Rightarrow W = 252.87 \text{ N}$$

12. Ans: (d)

Sol:

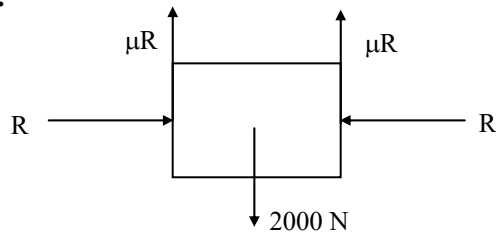

At equilibrium

$$2\mu R = 2000$$

$$\Rightarrow R = \frac{2000}{2 \times 0.1} = 10,000 \text{ N}$$

Taking moment about pin

$$10,000 \times 150 = F \times 300$$

$$\Rightarrow F = 5000 \text{ N}$$

13. Ans: (b)

Sol:

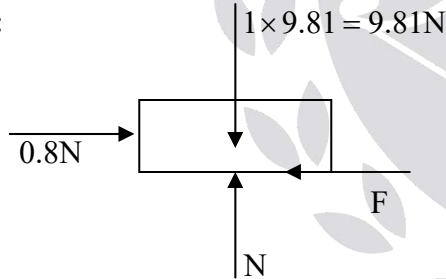

$$\Sigma Y = 0$$

$$\Rightarrow N = 9.81 \text{ N}$$

$$F_s = \mu N = 0.1 \times 9.81 = 0.98 \text{ N}$$

The External force applied = $0.8 \text{ N} < F_s$

\Rightarrow Frictional force = External applied
force = 0.8 N

14. Ans: (b)

Sol:

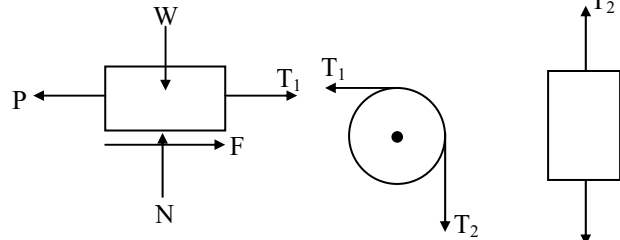

Fig: FBD (1)

Fig: FBD (2) Fig: FBD (3)

From FBD (3)

$$\Sigma F_y = 0$$

$$T_2 - 200 = 0$$

$$\Rightarrow T_2 = 200$$

From FBD (2)

$$\frac{T_1}{T_2} = e^{\mu\beta}$$

$$T_1 = T_2 e^{\mu\beta} = 200 \times e^{0.3 \times \frac{\pi}{2}}$$

$$T_1 = 320.39 \text{ N}$$

From FBD (1)

$$\Sigma F_y = 0$$

$$N - W = 0$$

$$N = 1000 \text{ N}$$

$$F = \mu N$$

$$= 0.3 \times 1000$$

$$F = 300 \text{ N}$$

$$\Sigma F_x = 0, T_1 + F - P = 0$$

$$320.39 + 300 = P$$

$$\Rightarrow P = 620.39$$

$$\Rightarrow P = 620.4 \text{ N}$$

Chapter

4

Free Vibrations of Undamped SDOF system
01. Ans: (b)

$$\text{Sol: } T = 2\pi\sqrt{\frac{L}{g}} \Rightarrow 0.5 = 2\pi \times \sqrt{\frac{L}{9.81}}$$

$$\Rightarrow L = 62.12 \text{ mm}$$

02. Ans: (c)

Sol: Let, V_0 is the initial velocity,
'm' is the mass

Equating Impulse = momentum

$$mV_0 = 5\text{kN} \times 10^{-4} \text{ sec}$$

$$= 5 \times 10^3 \times 10^{-4} = 0.5 \text{ sec}$$

$$\therefore V_0 = \frac{0.5}{m} = 0.5 \text{ m/sec}$$

$$\omega_n = \sqrt{\frac{k}{m}} = \sqrt{\frac{10000}{1}} = 100 \text{ rad/sec}$$

When the free vibrations are initiate with initial velocity,

The amplitude

$$X = \frac{V_0}{\omega_n} \text{ (Initial displacement)}$$

$$\therefore X = \frac{V_0}{\omega_n} = \frac{0.5 \times 10^3}{100} = 5 \text{ mm}$$

03. Ans: (a)

Sol: Note: ω_n depends on mass of the system
not on gravity

$$\therefore \omega_n \propto \frac{1}{\sqrt{m}}$$

$$\text{If } \omega_n = \sqrt{\frac{g}{\delta}}, \quad \delta = \frac{mg}{K}$$

$$\therefore \omega_n = \sqrt{\frac{g}{\left(\frac{mg}{K}\right)}} = \sqrt{\frac{K}{m}}$$

$\therefore \omega_n$ is constant every where.

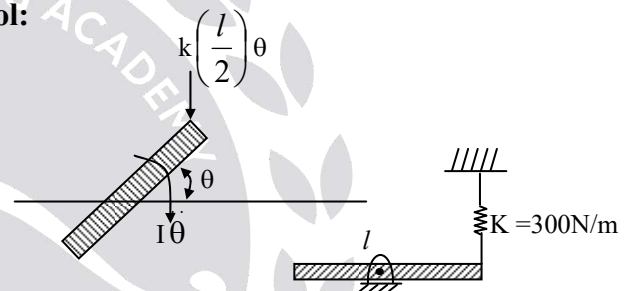
04. Ans: (c)
Sol:

By energy method

$$E = \frac{1}{2} I \dot{\theta}^2 + \frac{1}{2} K x^2 = \text{constant}$$

$$E = \frac{1}{2} I \dot{\theta}^2 + \frac{1}{2} K \times \left(\frac{l}{2} \theta\right)^2 = \text{constant}$$

Differentiating w.r.t 't'

$$\frac{dE}{dt} = I \ddot{\theta} + \frac{K}{2} \times \frac{l^2}{4} \times 2\theta = 0$$

$$I = \frac{ml^2}{12}$$

$$\frac{ml^2}{12} \ddot{\theta} + \frac{Kl^2}{4} \theta = 0$$

$$\Rightarrow \ddot{\theta} + \frac{3K}{m} \theta = 0$$

$$\Rightarrow \omega_n = \sqrt{\frac{3K}{m}} = 30 \text{ rad/sec}$$

05. Ans: (a)

06. Ans: (d)

Sol: $X_0 = 10 \text{ cm}$, $\omega_n = 5 \text{ rad/sec}$

$$X = \sqrt{x_0^2 + \left(\frac{v_0}{\omega_n}\right)^2}$$

If $v_0 = 0$ then $X = x_0$

$$\therefore X = x_0 = 10 \text{ cm}$$

07. Ans: 0.0658 N.m²

Sol: For a Cantilever beam stiffness, $K = \frac{3EI}{l^3}$

$$\text{Natural frequency, } \omega_n = \sqrt{\frac{K}{m}} = \sqrt{\frac{3EI}{m l^3}}$$

Given $f_n = 100 \text{ Hz}$

$$\Rightarrow \omega_n = 2\pi f_n = 200\pi$$

$$200\pi = \sqrt{\frac{3EI}{m l^3}}$$

Flexural Rigidity

$$EI = \frac{(200\pi)^2 \cdot m l^3}{3} = 0.0658 \text{ N.m}^2$$

08. Ans: (a)

Sol:

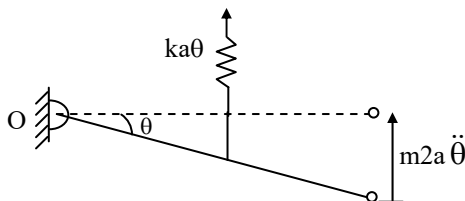

By taking the moment about 'O', $\Sigma m_o = 0$

$$(m2a\ddot{\theta} \times 2a) + (ka\theta \times a) = 0$$

$$\Rightarrow 4a^2 m \ddot{\theta} + ka^2 \theta = 0$$

Where, $m_{eq} = 4a^2 m$, $k_{eq} = ka^2$

Natural frequency, $\omega_n = \sqrt{\frac{k_{eq}}{m_{eq}}}$

$$= \sqrt{\frac{ka^2}{4a^2 m}} = \sqrt{\frac{k}{4m}} \text{ rad/sec}$$

$$[\because \omega_n = 2\pi f]$$

$$\Rightarrow f = \frac{\omega_n}{2\pi} = \frac{1}{2\pi} \times \sqrt{\frac{k}{4m}} \text{ Hz}$$

09. Ans: 10

Sol: Given Data:

$$m = 10 \text{ kg}$$

$$K = 4\pi^2 \times 10^3$$

\Rightarrow Natural frequency

$$f_n = \frac{1}{2\pi} \sqrt{\frac{k}{m}}$$

$$= \frac{1}{2\pi} \sqrt{\frac{4\pi^2 \times 10^3}{10}}$$

$$= \frac{2\pi \times 10}{2\pi} = 10$$

10. Ans: (a)

Sol:

$$1. \delta = \frac{PL^3}{12EI}$$

$$\therefore \text{Stiffness of bar, } K = \frac{P}{\delta} = \frac{12EI}{L^3}$$

2. Equivalent stiffness k_e ,
The bars are in parallel arrangement

$$\therefore k_e = k + k + k = \frac{36EI}{L^3}$$

3. Natural Frequency ω_n ,

$$\begin{aligned} \omega_n &= \sqrt{\frac{k_e}{m}} \text{ rad/sec} \\ &= \sqrt{\frac{36EI}{mL^3}} = 6\sqrt{\frac{EI}{mL^3}} \text{ rad/sec} \end{aligned}$$

11. Ans: (d)

Sol:

Beam and spring are parallel

$$w_n = \sqrt{\frac{K}{M}}$$

$$K_e = K_1 + K_2$$

$$K_1 = \frac{3EI}{\ell^3}, K_2 = K$$

$$w_n = \sqrt{\frac{\frac{3EI}{\ell^3} + K}{m}}$$

$$W_n = \sqrt{\frac{3EI + K\ell^3}{m}}$$

12. Ans: (a)

Sol: Beam and spring are in series

$$K_e = \frac{K_1 K_2}{K_1 + K_2}$$

$$K_2 = \frac{192EI}{\ell^3}, K_1 = K_1$$

$$w_n = \sqrt{\frac{K_e}{M}}$$

$$= \left(\frac{K_1 K_2}{M(K_1 + K_2)} \right)^{\frac{1}{2}}$$

13. Ans: (d)

Sol: $k_{eq} = k_1 + k_2 + k_3$

$$= \frac{12EI_c}{h^3} + \frac{12EI_c}{h^3} + \frac{12EI_c}{h^3}$$

$$k_{eq} = \frac{36EI_c}{h^3}$$

$$w_n = \sqrt{\frac{k_{eq}}{m}} = \sqrt{\frac{27EI_c}{h^3}}$$

$$w_n = \sqrt{\frac{27EI_c}{h^3 m}}$$

14. Ans: (c)

Sol: $k_{eq} = \frac{24EI_c}{h^3}$ ← as per formula when both

have EI_c

$$\begin{aligned} \therefore k_{eq} &= k_1 + k_2 \\ &= \frac{12EI_c}{h^3} + \frac{12(2EI_c)}{h^3} \\ &= \frac{36EI_c}{h^3} \end{aligned}$$

15. Ans: (d)

Sol:

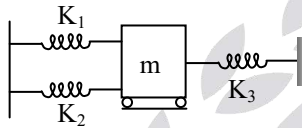

$$\begin{aligned} m &= 4 \text{ kg}, & K_1 &= 100 \text{ w/m} \\ K_2 &= 200 \text{ N/m} & K_3 &= 100 \text{ N/m} \\ K_e &= (K_1 + K_2) + K_3 = 400 \text{ N/m} \end{aligned}$$

$$T = \frac{2\pi}{\omega} = 2\pi \sqrt{\frac{M}{K}} = 2\pi \sqrt{\frac{4}{400}} = \frac{2\pi}{10}$$

$$T = 0.628 \text{ seconds}$$

16. Ans: (a)

$$\text{Sol: } p = \frac{\frac{EI_b}{L}}{2 \times \left[\frac{EI_c}{h} \right]} = \frac{\frac{EI_c}{2(2h)}}{2 \left[\frac{EI_c}{h} \right]} = \frac{1}{8}$$

$$k_{eq} = \frac{24EI_c}{h^3} \left[\frac{12 \left(\frac{1}{8} \right) + 1}{12 \left(\frac{1}{8} \right) + 4} \right]$$

$$k_{eq} = \frac{24EI_c}{h^3} \left[\frac{12 + 8}{12 + 32} \right]$$

$$k_{eq} = \frac{24EI_c}{h^3} \left[\frac{20}{44} \right]$$

$$k_{eq} = \sqrt{\frac{12EI_c}{11mh^3}}$$

17. Ans: (a)

Sol: Given:

Initial	Final
Mass = m	Mass = m/2
Stiffness = k	Stiffness = 2k
ω	$\omega_{final} = ?$
T	$T_{final} = ?$

$$\text{Natural frequency of spring} = \sqrt{\frac{k}{m}} = \omega$$

$$\text{In final condition} = \omega_{final} = \sqrt{\frac{2k}{m/2}}$$

$$= \sqrt{\frac{4k}{m}} = 2\sqrt{\frac{k}{m}} = 2\omega$$

$$T = \frac{2\pi}{\omega}; T_{final} = \frac{2\pi}{2\omega} = \frac{1}{2} = \frac{2\pi}{\omega} = \frac{1}{2}T$$

$$\therefore 2\omega \text{ rad/s \& } \frac{T}{2}$$

Strength of Materials

(Solutions for Text Book Practice Questions)

Chapter

1

Simple Stresses and Strains

Fundamental, Mechanical Properties of Materials, Stress Strain Diagram

01. Ans: (b)

Sol:

- **Ductility:** The property of materials to allow large deformations or large extensions without failure (large plastic zone) is termed as ductility.
- **Brittleness:** A brittle material is one which exhibits a relatively small extensions or deformations prior to fracture. Failure without warning (No plastic zone) i.e. no plastic deformation.
- **Tenacity:** High tensile strength.
- **Creep:** Creep is the gradual increase of plastic strain in a material with time at constant load.
- **Plasticity:** The property by which material undergoes permanent deformation even after removal of load.
- **Endurance limit:** The stress level below which a specimen can withstand cyclic stress indefinitely without failure.
- **Fatigue:** Decreased Resistance of material to repeated reversal of stresses.

02. Ans: (a)

Sol:

- When the material is subjected to stresses, it undergoes to strains. After removal of stress, if the strain is not restored/recovered, then it is called inelastic material.
- For rigid plastic material:

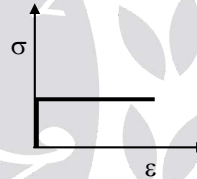

- Any material that can be subjected to large strains before it fractures is called a ductile material. Thus, it has large plastic zone.
- Materials that exhibit little or no yielding before failure are referred as brittle materials. Thus, they have no plastic zone.

03. Ans: (a)

Sol: Refer to the solution of Q. No. (01).

04. Ans: (b)

Sol: The stress-strain diagram for ductile material is shown below.

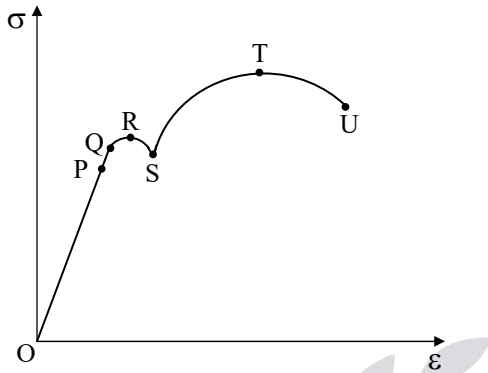

P – Proportionality limit
 Q – Elastic limit
 R – Upper yield point
 S – Lower yield point
 T – Ultimate tensile strength
 U – Failure

From above,

OP → Stage I
 PS → Stage II
 ST → Stage III
 TU → Stage IV

05. Ans: (b)

Sol:

- If the response of the material is independent of the orientation of the load axis of the sample, then we say that the material is **isotropic** or in other words we can say the isotropy of a material is its characteristics, which gives us the information that the properties are same in the three orthogonal directions x, y and z.

- A material is **homogeneous** if it has the same composition throughout the body. Hence, the elastic properties are the same at every point in the body in a given direction. However, the properties need not to be the same in all the directions for the material. Thus, both A and B are false.

06. Ans: (a)

Sol: **Strain hardening** increase in strength after plastic zone by rearrangement of molecules in material.

- Visco-elastic material** exhibits a mixture of creep as well as elastic after effects at room temperature. Thus their behavior is time dependant

07. Ans: (a)

Sol: Refer to the solution of Q. No. (01).

08. Ans: (a)

Sol: Modulus of elasticity (Young's modulus) of some common materials are as follow:

Material	Young's Modulus (E)
Steel	200 GPa
Cast iron	100 GPa
Aluminum	60 to 70 GPa
Timber	10 GPa
Rubber	0.01 to 0.1 GPa

09. Ans: (a)

Sol: Addition of carbon will increase strength, thereby ductility will decrease.

Elastic Constants and Their Relationships

01. Ans (c)

Sol: We know that,

$$\text{Poisson's ratio} = \frac{\text{Lateral strain}}{\text{Linear strain}} = \frac{\Delta D/D}{\Delta L/L}$$

$$\therefore \mu = \frac{\Delta D/8}{\frac{PL}{AE/L}}$$

$$\therefore \mu = \frac{\Delta D}{8} \frac{AE}{P}$$

$$\therefore 0.25 = \frac{\Delta D}{8} \frac{\pi (8)^2 \times 10^6}{50000}$$

$$\Rightarrow \Delta D = 1.98 \times 10^{-3} \cong 0.002 \text{ cm}$$

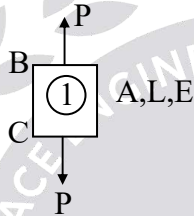

02. Ans: (c)

Sol: We know that,

$$\text{Bulk modulus} = \frac{\delta P}{\delta V/V}$$

$$\Rightarrow 2.5 \times 10^5 = \frac{200 \times 20}{\delta V}$$

$$\Rightarrow \delta V = 0.016 \text{ m}^3$$

Linear and Volumetric Changes of Bodies

01. Ans: (d)

Sol:

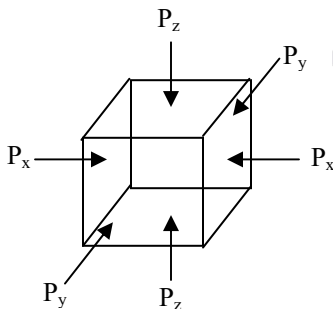

Let $P_y = P_z = P$

$\epsilon_y = 0$,

$$\epsilon_z = 0$$

$$\epsilon_y = \frac{\sigma_y}{E} - \mu \frac{\sigma_z}{E} - \mu \frac{\sigma_x}{E}$$

$$\therefore 0 = \frac{(-P)}{E} - \mu \frac{(-P)}{E} - \mu \frac{(P_x)}{E}$$

$$\Rightarrow P = \frac{\mu \cdot P_x}{(1 - \mu)}$$

02. Ans: (a)

Sol: Given that, $\sigma_c = 4\tau$

Punching force = Shear resistance of plate

$\therefore \sigma$ (Cross section area) = τ (surface Area)

$$\therefore 4 \times \tau \times \frac{\pi \cdot D^2}{4} = \tau (\pi \cdot D \cdot t)$$

$$\Rightarrow D = t = 10 \text{ mm}$$

03. Ans: (d)

Sol:

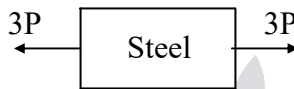

$$\sigma_s = 140 \text{ MPa} = \frac{P_s}{A_s}$$

$$\Rightarrow P_s = \frac{140 \times 500}{3} \approx 23,300 \text{ N}$$



$$\sigma_{Al} = 90 \text{ MPa} = \frac{P_{Al}}{A_{Al}}$$

$$\Rightarrow P_{Al} = 90 \times 400 = 36,000 \text{ N}$$



$$\sigma_B = 100 \text{ MPa} = \frac{P_B}{A_B}$$

$$\Rightarrow P_B = \frac{100 \times 200}{2} = 10,000 \text{ N}$$

Take minimum value from P_s , A_{Al} and P_B .

$$\Rightarrow P = 10,000 \text{ N}$$

04. Ans: (c)

Sol:

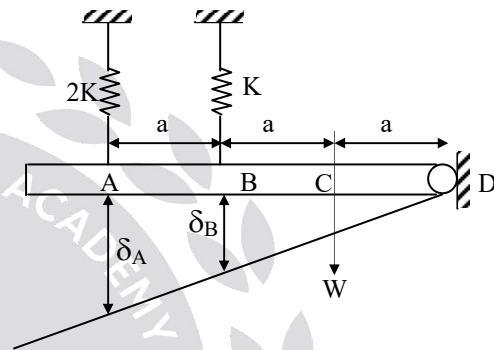

From similar triangle

$$\frac{3a}{\delta_A} = \frac{2a}{\delta_B}$$

$$3\delta_B = 2\delta_A \dots\dots (1)$$

$$\text{Stiffness } K = \frac{W}{\delta}$$

$$\therefore K_A = \frac{W_A}{\delta_A} \Rightarrow \delta_A = \frac{W_A}{2K}$$

$$\text{Similarly } \delta_B = \frac{W_B}{K}$$

$$\text{From equation (1)} \quad 3 \times \frac{W_B}{K} = 2 \times \frac{W_A}{2K}$$

$$\Rightarrow \frac{W_A}{W_B} = 3$$

Thermal/Temperature Stresses
01. Ans: (b)
Sol: Free expansion = Expansion prevented

$$[\ell \alpha t]_s + [\ell \alpha t]_{Al} = \left[\frac{P\ell}{AE} \right]_s + \left[\frac{P\ell}{AE} \right]_{Al}$$

$$11 \times 10^{-6} \times 20 + 24 \times 10^{-6} \times 20$$

$$= \frac{P}{100 \times 10^3 \times 200} + \frac{P}{200 \times 10^3 \times 70}$$

$$\Rightarrow P = 5.76 \text{ kN}$$

$$\sigma_s = \frac{P}{A_s} = \frac{5.76 \times 10^3}{100} = 57.65 \text{ MPa}$$

$$\sigma_{Al} = \frac{P}{A_{al}} = \frac{5.76 \times 10^3}{200} = 28.82 \text{ MPa}$$

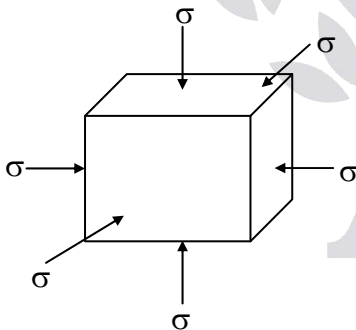
02. Ans: (a)
Sol:

Strain in X-direction due to temperature,

$$\epsilon_t = \alpha(\Delta T)$$

Strain in X-direction due to volumetric stress,

$$\epsilon_x = \frac{\sigma_x}{E} - \mu \frac{\sigma_y}{E} - \mu \frac{\sigma_z}{E}$$

$$\therefore \epsilon_x = \frac{-\sigma}{E}(1 - 2\mu)$$

$$\therefore -\sigma = \frac{(\epsilon_x)(E)}{1 - 2\mu}$$

$$\therefore -\sigma = \frac{\alpha(\Delta T)E}{(1 - 2\mu)}$$

$$\Rightarrow \sigma = \frac{-\alpha(\Delta T)E}{1 - 2\mu}$$

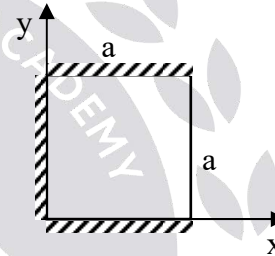
03. Ans: (b)
Sol:

- Free expansion in x direction is $\alpha \alpha t$.
- Free expansion in y direction is $\alpha \alpha t$.
- Since there is restriction in y direction expansion doesn't take place. So in lateral direction, increase in expansion due to restriction is $\mu \alpha \alpha t$.

Thus, total expansion in x direction is,

$$= a \alpha t + \mu a \alpha t$$

$$= a \alpha t (1 + \mu)$$

04. Ans: (a, b, d)
Sol:

- Brass and copper bars are in parallel arrangement in composite bar.
- In parallel arrangement load is divided and elongation will be same for both the bars.

$$P = P_b + P_c$$

$$P = A_b \sigma_b + A_c \sigma_c$$

$$\delta_b = \delta_c$$

$$\Rightarrow \frac{Pl}{AE} \Big|_b = \frac{Pl}{AE} \Big|_c$$

$$\therefore l_b = l_c$$

$$\therefore \frac{\sigma_b}{\sigma_c} = \frac{E_b}{E_c}$$

Hence, a, b, d are correct.

05. Ans: (b, d)

Sol: Elongation produced in prismatic bar due to self weight.

$$\delta l = \frac{\gamma \ell^2}{2E}$$

γ = weight density

Now, $\ell \rightarrow 2\ell$

$$\delta l' = \frac{\gamma \times (2\ell)^2}{2E} = 4\delta l$$

Elongation produced will be 4 times original elongation.

Stress = $E \times$ strain

$$\sigma = E \times \frac{\delta l}{\ell} = E \times \frac{\gamma \ell}{2E}$$

$$\sigma' = E \times \frac{\gamma 2\ell}{2E}$$

$$\sigma' = 2\sigma$$

Stress produced will be 2 times maximum stress.

Chapter

2

Complex Stresses and Strains

01. Ans: (b)

Sol: Maximum principal stress $\sigma_1 = 18$

Minimum principal stress $\sigma_2 = -8$

$$\text{Maximum shear stress} = \frac{\sigma_1 - \sigma_2}{2} = 13$$

Normal stress on Maximum shear stress plane

$$= \frac{\sigma_1 + \sigma_2}{2} = \frac{18 + (-8)}{2} = 5$$

02. Ans: (b)

Sol: Radius of Mohr's circle, $\tau_{\max} = \frac{\sigma_1 - \sigma_2}{2}$

$$\therefore 20 = \frac{\sigma_1 - 10}{2}$$

$$\Rightarrow \sigma_1 = 50 \text{ N/mm}^2$$

03. Ans: (b)

Sol: Given data,

$$\sigma_x = 150 \text{ MPa}, \sigma_y = -300 \text{ MPa}, \mu = 0.3$$

Long dam \rightarrow plane strain member

$$\varepsilon_z = 0 = \frac{\sigma_z}{E} - \frac{\mu \sigma_x}{E} - \frac{\mu \sigma_y}{E}$$

$$\therefore 0 = \sigma_z - 0.3 \times 150 + 0.3 \times 300$$

$$\Rightarrow \sigma_z = 45 \text{ MPa}$$

04. Ans: (b)

Sol:

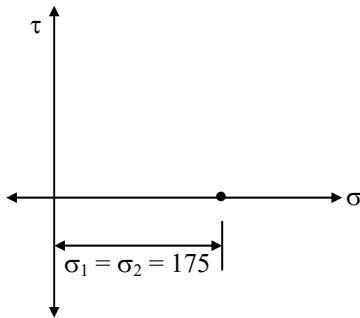

From the above, we can say that Mohr's circle is a point located at 175 MPa on normal stress axis.

Thus, $\sigma_1 = \sigma_2 = 175 \text{ MPa}$

05. Ans: (c)

Sol: Given that, $\sigma_2 = 0$

$$\therefore \sigma_2 = \frac{\sigma_x + \sigma_y}{2} - \sqrt{\left(\frac{\sigma_x - \sigma_y}{2}\right)^2 + \tau_{xy}^2}$$

$$\therefore \frac{\sigma_x + \sigma_y}{2} = \sqrt{\left(\frac{\sigma_x - \sigma_y}{2}\right)^2 + \tau_{xy}^2}$$

$$\therefore \left(\frac{\sigma_x + \sigma_y}{2}\right)^2 = \left(\frac{\sigma_x - \sigma_y}{2}\right)^2 + \tau_{xy}^2$$

$$\therefore \tau_{xy}^2 = \left(\frac{\sigma_x + \sigma_y}{2}\right)^2 - \left(\frac{\sigma_x - \sigma_y}{2}\right)^2$$

$$\therefore \tau_{xy}^2 = \sigma_x \cdot \sigma_y$$

$$\Rightarrow \tau_{xy} = \sqrt{\sigma_x \cdot \sigma_y}$$

06. Ans: (a, b, d)

Sol:

- Planes on which resultant stress as a result of external loading is purely normal stress i.e., shear stress is zero.
- Such planes are called as principal planes and the corresponding normal stresses are called as principal stresses.
- Principal stress may be maximum or minimum.
- Planes of maximum shear stresses are there in which shear stress is maximum but normal stress is non-zero.

07. Ans: (a, b, c)

Sol:

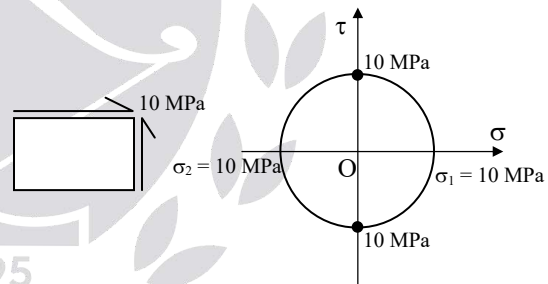

Diameter of Mohr's circle would be $10 + 10 = 20 \text{ MPa}$

Maximum principal stress = 10 MPa

Minimum principal stress = -10 MPa

Centre of Mohr's circle is at origin.

Maximum shear stress = 10 MPa

Hence, option (a, b, c) are correct.

Chapter

3

Shear Force and Bending Moment

01. Ans: (b)

Sol: Contra flexure is the point where BM is becoming zero.

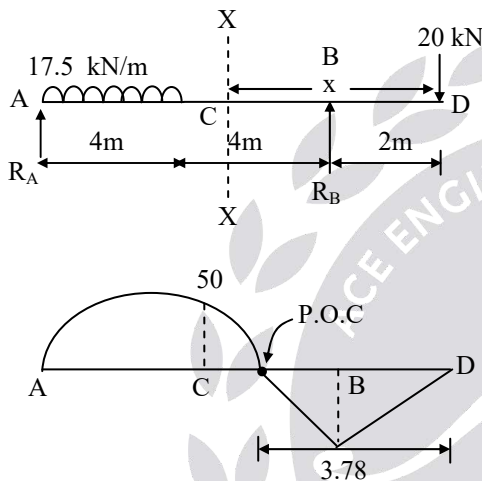

Taking moment about A,

$$\sum M_A = 0$$

$$\therefore 17.5 \times 4 \times \frac{4}{2} + 20 \times 10 - R_B \times 8 = 0$$

$$\therefore R_B = 42.5 \text{ kN}$$

Now, $M_x = -20x + R_B(x - 2)$

For bending moment be zero $M_x = 0$,

$$-20x + 42.5(x - 2) = 0$$

$$\Rightarrow x = 3.78 \text{ m from right i.e. from D.}$$

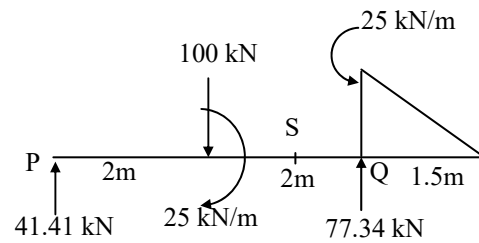
02. Ans: (b)
Sol:

Take $\sum M_P = 0$

$$\frac{1}{2} \times 25 \times 1.5 \times \left(\frac{1.5}{3} + 4 \right) - (R_Q \times 4) + 100 \times 2 + 25 = 0$$

$$\therefore R_Q = 77.34 \text{ kN}$$

Also, $\sum V = 0$

$$\therefore R_P + R_Q = 100 + \frac{1}{2} \times 25 \times 1.5 = 118.75 \text{ kN}$$

$$\therefore R_P = 41.41 \text{ kN}$$

$$\Rightarrow \text{Shear force at P} = 41.41 \text{ kN}$$

03. Ans: (c)

Sol: $M_S = R_P(3) + 25 - (100 \times 1) = 49.2 \text{ kN-m}$

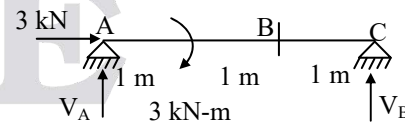
04. Ans: (c)
Sol:

$$-V_B \times 3 + 3 = 0$$

$$\therefore V_C = 1 \text{ kN}$$

\therefore Bending moment at B,

$$\Rightarrow M_B = V_C \times 1 = 1 \text{ kN-m}$$

05. Ans: (a)

Sol:

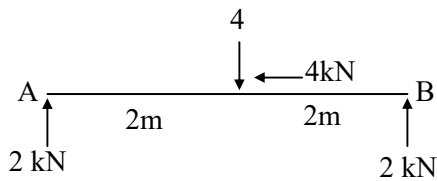

Reaction at both the supports are 2 kN and in upward direction.

06. Ans: (c)

Sol:

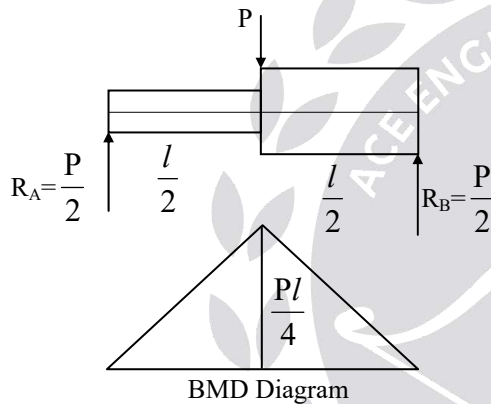

Bending moment at $\frac{l}{2}$ from left is $\frac{Pl}{4}$.

The given beam is statically determinate structure. Therefore equilibrium equations are sufficient to analyze the problem.

In statically determinate structure the BMD, SFD and Axial force are not affected by section (I), material (E), thermal changes.

07. Ans: (a)

Sol: As the given support is hinge, for different set of loads in different direction beam will experience only axial load.

08. Ans: (b, c, d)

Sol:

- Bending moment diagram (BMD) is constant in both the regions with different sign. So only BM is present in the loading diagram.
- BM at 'C' becomes zero from 20 kN-m indicates a concentrated moment and the end A is fixed.

09. Ans: (b, c)

Sol:

- For point load shear force will always be constant.
- There is no change in the shear force diagram due to presence of bending moment at any point.

Hence, option (a & d) are wrong statements.

Chapter

4

Centre of Gravity & Moment of Inertia

01. Ans: (a)

$$\text{Sol: } \bar{y} = \frac{E_1 y_1 + E_2 y_2}{E_1 + E_2}$$

$$\Rightarrow \bar{y} = \frac{2E_2 \left(h + \frac{h}{2} \right) + E_2 \times \frac{h}{2}}{2E_2 + E_2} \quad (\because E_1 = 2E_2)$$

$$\Rightarrow \bar{y} = 1.167h \text{ from base}$$

02. Ans: (b)

$$\text{Sol: } \bar{y} = \frac{A_1 E_1 Y_1 + A_2 E_2 Y_2}{A_1 E_1 + A_2 E_2}$$

$$= \frac{1.5a \times 3a^2 \times E_1 + 1.5a \times 6a^2 \times 2E_1}{3a^2 E_1 + 6a^2 (2E_1)}$$

$$= \frac{22.5a^3 E_1}{15a^2 E_1} = 1.5a$$

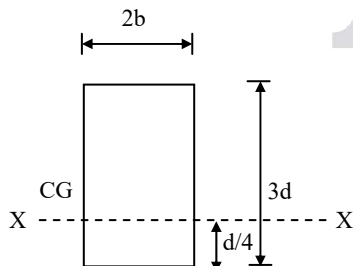
03. Ans: $13.875 bd^3$
Sol:

$$\text{M.I about CG} = I_{CG} = \frac{2b(3d)^3}{12} = \frac{9}{2} bd^3$$

$$\text{M.I about X - X} \Big|_{\text{at } \frac{d}{4} \text{ distance}} = I_G + Ay^2$$

$$= \frac{9}{2} bd^3 + 6bd \left(\frac{5}{4} \right)^2 d^2$$

$$= \frac{111}{8} bd^3 = 13.875bd^3$$

04. Ans: $6.885 \times 10^6 \text{ mm}^4$
Sol:

$$I_x = \frac{BD^3}{12} - 2 \left(\frac{bd^3}{12} + Ah^2 \right)$$

$$= \frac{60 \times 120^3}{12} - 2 \left(\frac{30 \times 30^3}{12} + (30 \times 30) \times 30^2 \right)$$

$$= 6.885 \times 10^6 \text{ mm}^4$$

05. Ans: 152146 mm^4
Sol:

$$I_x = \frac{30 \times 40^3}{12} - \frac{\pi \times 20^4}{64} = 152146 \text{ mm}^4$$

$$I_y = \frac{40 \times 30^3}{12} - \left(\frac{\pi \times 20^4}{64} + 2 \left(\frac{\pi}{2} \times 10^2 \times \left(15 - \frac{4 \times 10}{3\pi} \right)^2 \right) \right)$$

$$= 45801.34 \text{ mm}^4$$

Chapter

5

Theory of Simple Bending

01. Ans: (b)

Sol:

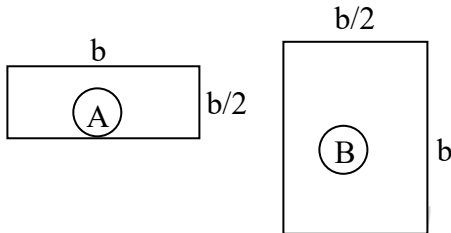

By using flexural formula, $\sigma = \frac{M}{Z}$

$$\therefore \sigma \propto \frac{1}{Z} \quad (\because M \text{ is constant})$$

$$\therefore \frac{\sigma_A}{\sigma_B} = \frac{Z_B}{Z_A} = \frac{\frac{6}{\left(\frac{b}{2} \times b^2\right)}}{b \times \left(\frac{b}{2}\right)^2} = 2$$

$$\Rightarrow \sigma_A = 2\sigma_B$$

02. Ans: (b)

Sol:

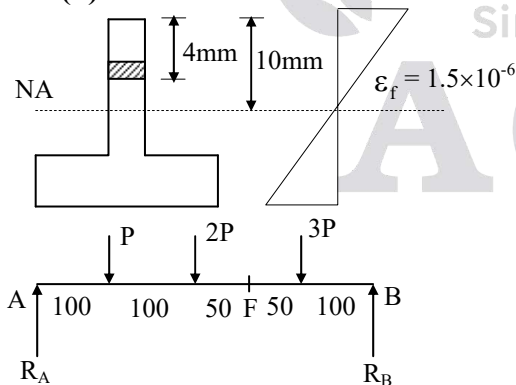

$$\therefore \sum M_A = 0$$

$$\therefore P \times 100 + 2P \times 200 + 3P \times 300 = R_B \times 400$$

$$\therefore R_B = 3.5 P, \quad R_A = 2.5 P$$

Take moments about F and moment at F

$$M_F = R_B \times 150 - 3P \times 50 = 375P$$

$$\text{Also, } \frac{M_F}{I} = \frac{\sigma_b}{y_F}$$

$$\therefore \frac{375P}{2176} = \frac{(1.5 \times 10^{-6} \times 200 \times 10^3)}{6}$$

$$\Rightarrow P = 0.29 \text{ N}$$

03. Ans: (b)

Sol: By using Flexural formula,

$$\frac{E}{R} = \frac{\sigma_b}{y_{\max}} \Rightarrow \frac{2 \times 10^5}{250} = \frac{\sigma_b}{(0.5/2)}$$

$$\Rightarrow \sigma_b = 200 \text{ N/mm}^2$$

04. Ans: (c)

Sol:

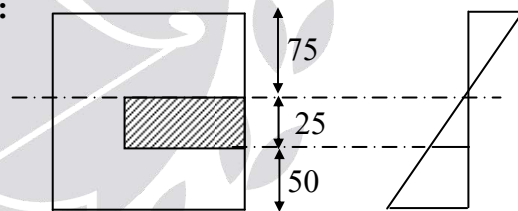

By using flexural formula,

$$\frac{M}{I} = \frac{f}{y}$$

$$\therefore \frac{16 \times 10^6}{100 \times 150^3} = \frac{f}{25} \Rightarrow f = 14.22 \text{ MPa}$$

Now, Force on hatched area

$$= \text{Average stress} \times \text{Hatched area}$$

$$= \left(\frac{0 + 14.22}{2} \right) (25 \times 50) = 8.9 \text{ kN}$$

05. Ans: (b)

Sol: By using flexural formula, $\frac{f_{\text{Tensile}}}{y_{\text{top}}} = \frac{M}{I}$

$$\Rightarrow f_{\text{Tensile}} = \frac{0.3 \times 3 \times 10^6}{3 \times 10^6} \times 70$$

(maximum bending stress will be at top fibre so $y_1 = 70$ mm)

$$\Rightarrow f_{\text{Tensile}} = 21 \text{ N/mm}^2 = 21 \text{ MN/m}^2$$

06. Ans: (c)

Sol: Given data:

$$\begin{aligned} P &= 200 \text{ N}, & M &= 200 \text{ N.m} \\ A &= 0.1 \text{ m}^2, & I &= 1.33 \times 10^{-3} \text{ m}^4 \\ y &= 20 \text{ mm} \end{aligned}$$

Due to direct tensile force P,

$$\begin{aligned} \sigma_d &= \frac{P}{A} = \frac{200}{0.1} \\ &= 2000 \text{ N/m}^2 \text{ (Tensile)} \end{aligned}$$

Due to the moment M,

$$\begin{aligned} \sigma_b &= \frac{M}{I} \times y \\ &= \frac{200}{1.33 \times 10^{-3}} \times 20 \times 10^{-3} \\ &= 3007.52 \text{ N/m}^2 \text{ (Compressive)} \end{aligned}$$

$$\begin{aligned} \sigma_{\text{net}} &= \sigma_d - \sigma_b \\ &= 2000 - 3007.52 \\ &= -1007.52 \text{ N/m}^2 \end{aligned}$$

Negative sign indicates compressive stress.

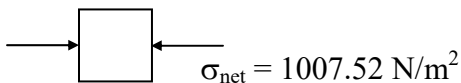

07. Ans: 80 MPa

Sol:

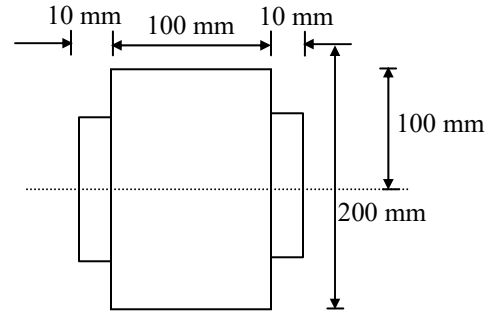

Maximum stress in timber = 8 MPa

Modular ratio, $m = 20$

Stress in timber in steel level,

$$\begin{aligned} 100 &\rightarrow 8 \\ 50 &\rightarrow f_w \\ \Rightarrow f_w &= 4 \text{ MPa} \end{aligned}$$

Maximum stress developed in steel is = $m \cdot f_w$
 $= 20 \times 4 = 80 \text{ MPa}$

Convert whole structure as a steel structure by using modular ratio.

08. Ans: 2.43 mm

Sol: From figure, $A_1B_1 = l = 3$ m (given)

$$AB = \left(R - \frac{h}{2} \right) \alpha = l - l\alpha t_1 \text{ ----- (1)}$$

$$A_2B_2 = \left(R + \frac{h}{2} \right) \alpha = l + l\alpha t_2 \text{ ----- (2)}$$

Subtracting above two equations (2) - (1)

$$h(\alpha) = l\alpha(t_2 - t_1)$$

but $A_1B_1 = l = R\alpha$

$$\Rightarrow \alpha = \frac{l}{R}$$

$$\therefore h \left(\frac{l}{R} \right) = l\alpha(\Delta T)$$

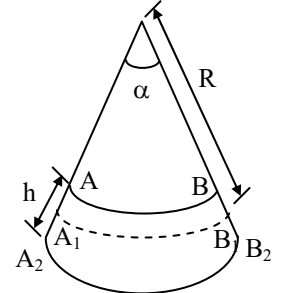

$$R = \frac{h}{\alpha(\Delta T)}$$

$$= \frac{250}{(1.5 \times 10^{-5})(72 - 36)}$$

$$R = 462.9 \text{ m}$$

From geometry of circles

$$(2R - \delta)\delta = \frac{L}{2} \cdot \frac{L}{2} \quad \{\text{ref. figure in Q.No.02}\}$$

$$2R \cdot \delta - \delta^2 = \frac{L^2}{4} \quad (\text{neglect } \delta^2)$$

$$\delta = \frac{L^2}{8R} = \frac{3^2}{8 \times 462.9} = 2.43 \text{ mm}$$

Shortcut:

Deflection is due to differential temperature of bottom and top ($\Delta T = 72^\circ - 36^\circ = 36^\circ$). Bottom temperature being more, the beam deflects down.

$$\delta = \frac{\alpha(\Delta T)\ell^2}{8h}$$

$$= \frac{1.5 \times 10^{-5} \times 36 \times 3000^2}{8 \times 250}$$

$$= 2.43 \text{ mm (downward)}$$

09. Ans: (a, c)

Sol:

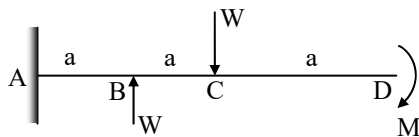

$$BM_C = M$$

$$BM_B = M + Wa$$

$$BM_A = M + W(2a) - Wa = M + Wa$$

Taking a section between A & B

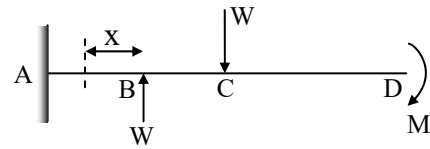

$$M_{xx} = M + W(a+x) - Wx$$

$$= M + Wa$$

So, pure bending theory is valid in constant B.M region.

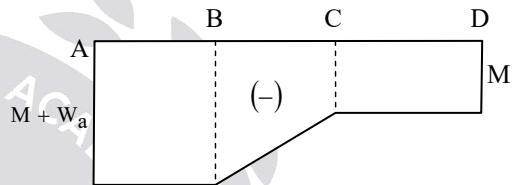

Chapter

6

Shear Stress Distribution in Beams

01. Ans: (a)

$$\text{Sol: } \tau_{\max} = \frac{3}{2} \times \tau_{\text{avg}} = \frac{3}{2} \times \frac{f}{b.d}$$

$$3 = \frac{3}{2} \times \frac{50 \times 10^3}{100 \times d}$$

$$\therefore d = 250 \text{ mm} = 25 \text{ cm}$$

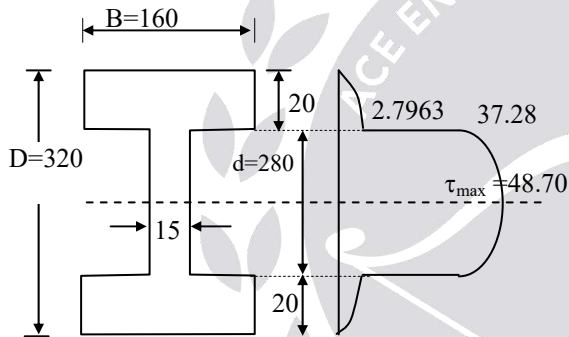
02. Ans: 37.3
Sol:

All dimensions are in mm

Bending moment (M) = 100 kN-m,

Shear Force (SF) = f = 200 kN

$$I = \frac{160 \times 320^3}{12} - \frac{145 \times 280^3}{12}$$

$$= 171.65 \times 10^6 \text{ mm}^4$$

$$\tau_{\text{at interface of flange \& web}} = \frac{FA\bar{y}}{Ib}$$

$$= \frac{200 \times 10^3}{171.65 \times 10^6 \times 15} \times (160 \times 20 \times 150)$$

$$= 37.28 \text{ MPa}$$

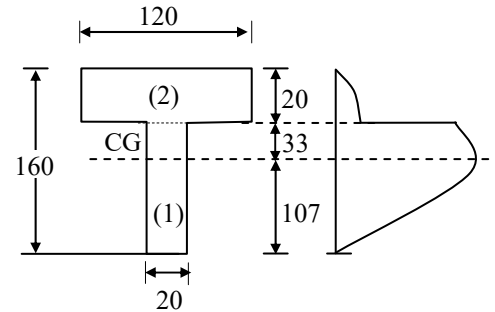
03. Ans: 61.43 MPa
Sol:

All dimensions are in mm

$$I_{NA} = 13 \times 10^6 \text{ mm}^4$$

$$y_{CG} = 107 \text{ mm from base}$$

$$\tau_{\max} = \frac{FA\bar{y}}{Ib}$$

$$A\bar{y} = (120 \times 20 \times 43) + (33 \times 20 \times 16.5)$$

$$= 114090 \text{ mm}^3$$

$$\tau_{\max} = \frac{140 \times 10^3 \times 114090}{13 \times 10^6 \times 20} = 61.43 \text{ MPa}$$

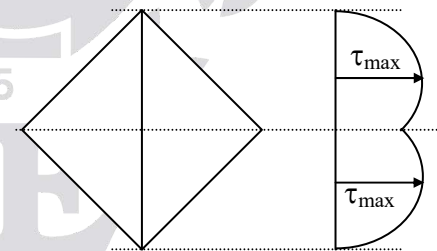
04. Ans: (b, c)
Sol:

From the above diagram, the shear force distribution across the section of beam will be zero at top and bottom.

Maximum shear stress does not occur at the neutral axis.

Hence, options (b, c) are correct.

Chapter
7
Torsion
01. Ans: (c)

Sol: Twisting moment = $2 \times 0.5 + 1 \times 0.5$
 = 1.5 kN-m

02. Ans: (d)

Sol:
$$\frac{(\text{Strength})_{\text{solid}}}{(\text{Strength})_{\text{hollow}}} = \frac{1}{1 - K^4}$$

$$= \frac{1}{1 - \left(\frac{1}{2}\right)^4} = \frac{16}{15}$$

03. Ans: 43.27 MPa & 37.5 MPa

Sol: Given $D_o = 30 \text{ mm}$, $t = 2 \text{ mm}$
 $\therefore D_i = 30 - 4 = 26 \text{ mm}$

We know that $\frac{\tau}{J} = \frac{q}{R}$

$$\frac{100 \times 10^3}{\pi(30^4 - 26^4)} = \frac{q_{\text{max}}}{\left(\frac{30}{2}\right)}$$

$$q_{\text{max}} = 43.279 \text{ N/mm}^2$$

$$\frac{100 \times 10^3}{\pi(30^4 - 26^4)} = \frac{q_{\text{min}}}{\left(\frac{26}{2}\right)}$$

$$q_{\text{min}} = 37.5 \text{ N/mm}^2$$

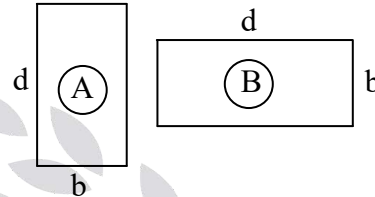
Chapter
8
Slopes and Deflections
01. Ans: (c)
Sol:

$$y_{\text{max}} \propto \frac{1}{I}$$

$$\therefore \frac{y_A}{y_B} = \frac{I_B}{I_A}$$

$$y_B = \frac{y_A \times bd^3 / 12}{db^3 / 12} \Rightarrow y_B = \left(\frac{d}{b}\right)^2 y_A$$

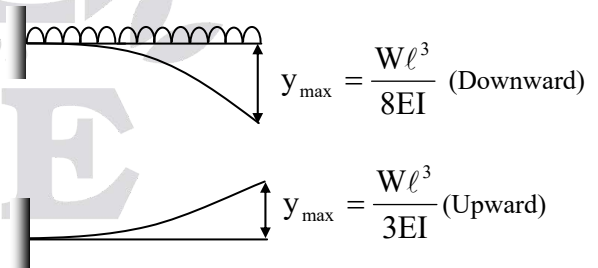
02. Ans: (b)
Sol: Total load $W = wl$

$$y_{\text{net}} = \downarrow y_{udl} - \uparrow y_w$$

$$\text{Total Net deflection} = \frac{WL^3}{8EI} - \frac{WL^3}{3EI}$$

$$= \frac{-5WL^3}{24EI}$$

(Negative sign indicates upward deflection)

03. Ans: (c)

Sol:

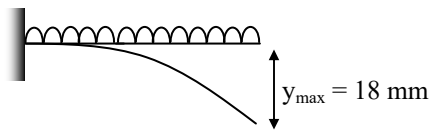

$$\theta_{\max} = \frac{wl^3}{6EI} = 0.02 \text{ -----(i)}$$

$$y_{\max} = \frac{wL^4}{8EI}$$

$$\therefore 0.018 = \left(\frac{WL^3}{6EI} \right) \times \frac{L \times 6}{8}$$

$$\therefore 0.018 = \frac{0.02 \times L \times 6}{8} \quad [\because \text{Equation (i)}]$$

$$\Rightarrow L = 1.2 \text{ m}$$

04. Ans: (a)

Sol:

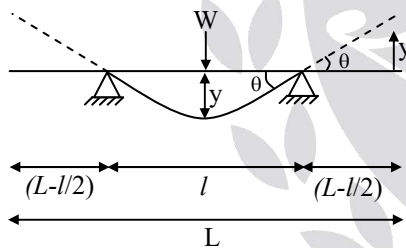

Conditions given

$$\downarrow y = \frac{wl^3}{48EI}$$

$$\theta = \frac{wl^2}{16EI}$$

$$\tan\theta = \frac{y}{(L-l)/2}$$

θ is small $\Rightarrow \tan \theta = \theta$

$$\therefore \theta = \frac{y}{(L-l)/2}$$

$$\therefore y = \theta \left(\frac{L-l}{2} \right)$$

$$\uparrow y = \theta \left(\frac{L-l}{2} \right)$$

Thus $y \downarrow = y \uparrow$

$$\therefore \frac{wl^3}{48EI} = \frac{wl^2}{16EI} \times \left(\frac{L-l}{2} \right)$$

$$\Rightarrow \frac{L}{l} = \frac{5}{3}$$

05. Ans: (c)

Sol: By using Maxwell's law of reciprocals theorem

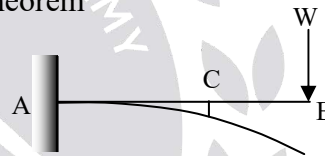

$$\delta_{C/B} = \delta_{B/C}$$

Deflection at 'C' due to unit load at 'B'

= Deflection at 'B' due to unit load at 'C'

As the load becomes half deflection becomes half.

06. Ans: (c)

Sol:

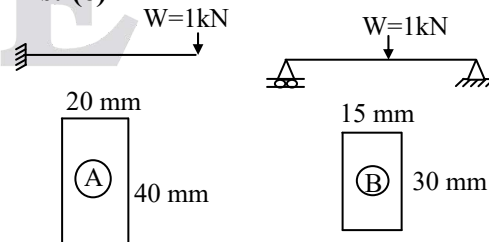

$$y_A = y_B \Rightarrow \left(\frac{wL^3}{3EI} \right)_A = \left(\frac{wL^3}{48EI} \right)_B$$

$$\therefore L_B = 400 \text{ mm}$$

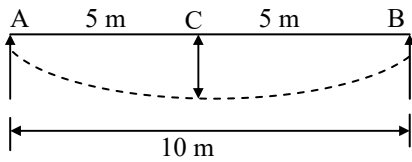
07. Ans: 0.05
Sol:

$$\therefore \text{Curvature, } \frac{d^2y}{dx^2} = 0.004$$

 Integrating with respect to x ,

$$\text{We get, } \frac{dy}{dx} = 0.004x$$

$$y = \frac{0.004x^2}{2}$$

$$y = 0.002x^2$$

 At mid span, $x = 5 \text{ m}$

$$\therefore y = 0.002 \times 5^2$$

$$y = 0.05 \text{ m}$$

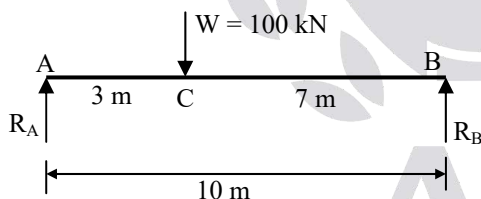
08. Ans: (a, b, d)
Sol:

$$R_A + R_B = 100$$

$$M_A = 0$$

$$R_B \times 10 = 100 \times 3$$

$$R_B = 30 \text{ kN}$$

$$R_A = 70 \text{ kN}$$

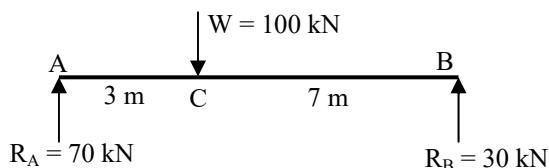

Using conjugate beam method,

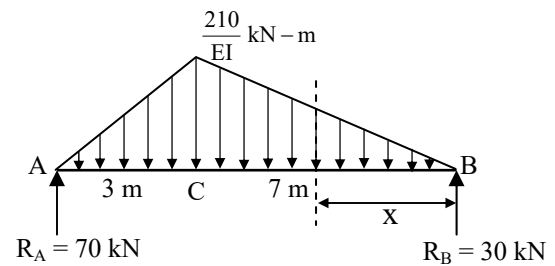

Taking moment about point A,

$$R_B \times 10 = \frac{1}{2} \times 7 \times \frac{210}{EI} \left[\left(7 - 7 \times \frac{2}{3} \right) + 3 \right] + \frac{1}{2} \times 3 \times \frac{210}{EI} \left(3 \times \frac{2}{3} \right)$$

$$= \frac{105}{EI} \left[\left(7 \times \frac{16}{3} \right) + 6 \right]$$

$$R_B = \frac{455}{EI} \text{ kN}$$

For maximum deflection shear force = 0

$$(SF)_x = \frac{1}{2} \times x \times \frac{30x}{EI} - \frac{455}{EI} = 0$$

$$15x^2 = 455$$

$$\Rightarrow x = 5.50 \text{ m, which lies between B and C.}$$

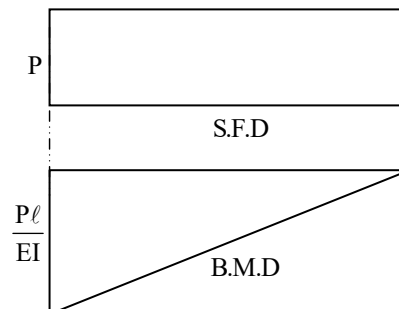
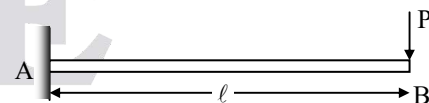
09. Ans: (b, c)
Sol: Cantilever beam subjected to a concentrated load at the free end.

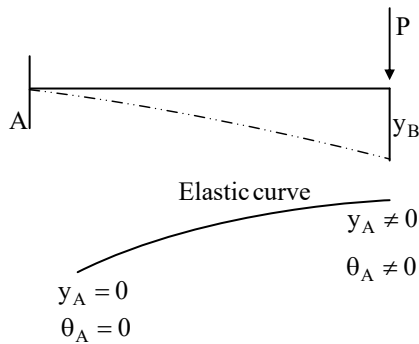

From the above diagram bending moment or stress is maximum at fixed end.

From SFD, shear stress is constant along the length of the beam.

Slope of elastic curve is zero at fixed end and maximum at free end.

Hence, option (b, c) are correct.

Chapter
9
Thin Pressure Vessels

01. Ans: (b)

$$\text{Sol: } \tau_{\max} = \sigma_1 = \frac{\sigma_h - 0}{2} = \frac{PD}{4t}$$

$$\therefore \tau_{\max} = \frac{1.6 \times 900}{4 \times 12} = 30 \text{ MPa}$$

02. Ans: 2.5 MPa & 2.5 MPa

Sol: Given data:

$$R = 0.5 \text{ m, } D = 1 \text{ m, } t = 1 \text{ mm,}$$

$$H = 1 \text{ m, } \gamma = 10 \text{ kN/m}^3, h = 0.5 \text{ m}$$

At mid-depth of cylindrical wall ($h = 0.5 \text{ m}$):

Circumferential (hoop) stress,

$$\begin{aligned} \sigma_c &= \frac{P_{\text{at } h=0.5\text{m}} \times D}{4t} = \frac{\gamma h \times D}{4t} \\ &= \frac{10 \times 10^3 \times (2 \times 0.5)}{4 \times 1 \times 10^{-3}} \\ &= 2.5 \times 10^6 \text{ N/m}^2 = 2.5 \text{ MPa} \end{aligned}$$

Longitudinal stress at mid-height,

$$\begin{aligned} \sigma_l &= \frac{\text{Net weight of the water}}{\text{Cross-section area}} \\ &= \frac{\gamma \times \text{Volume}}{\pi D \times t} \\ &= \frac{\gamma \times \frac{\pi}{4} D^2 L}{\pi D \times t} = \frac{\gamma \times DL}{4t} \\ &= \frac{10 \times 10^3 \times 1 \times 1}{4 \times 10^{-3}} \\ &= 2.5 \times 10^6 \text{ N/m}^2 = 2.5 \text{ MPa} \end{aligned}$$

03. Ans: (a, c)

Sol: Pressure vessel is open from both ends. So, longitudinal stress, $\sigma_l = 0$

Longitudinal strain (ϵ_L)

$$= \epsilon_L - \mu \epsilon_c$$

$$= -\mu \frac{Pd}{2tE}$$

$$= -\frac{\mu \sigma_c}{E}$$

Circumferential strain = $\epsilon_h - \mu \epsilon_l$

$$\epsilon_h = \frac{Pd}{2tE} - \mu \times 0$$

$$= \frac{Pd}{2tE}$$

Hoop or circumferential stress,

$$\sigma_h = \frac{Pd}{2t}$$

Hence, options (a, c) are correct.

Chapter

10

Columns

01. Ans: (c)

Sol: By using Euler's formula, $P_e = \frac{\pi^2 \times EI}{l_e^2}$

For a given system, $l_e = \frac{l}{2}$

$$P_e = \frac{4\pi^2 \times EI}{l^2}$$

02. Ans: (b)

Sol: We know that, $P_{cr} = \frac{\pi^2 EI}{l_e^2}$

$$\therefore P_{cr} \propto \frac{1}{l_e^2}$$

$$\therefore \frac{P_1}{P_2} = \frac{l_{2e}^2}{l_{1e}^2}$$

$$\therefore \frac{P_1}{P_2} = \frac{l^2}{(2l)^2} \Rightarrow P_1 : P_2 = 1 : 4$$

03. Ans: 4

Sol: Euler's crippling load,

$$P = \frac{\pi^2}{l^2} EI$$

$$\therefore P \propto I$$

$$\Rightarrow \frac{P}{P_o} = \frac{I_{\text{bonded}}}{I_{\text{loose}}} = \frac{\left[\frac{b(2t)^3}{12} \right]}{2 \left[\frac{bt^3}{12} \right]} = 4$$

04. Ans: (c)

Sol: Euler's theory is applicable for axially loaded columns.

$$\text{Force in member AB, } P_{AB} = \frac{F}{\cos 45^\circ} = \sqrt{2}F$$

$$P_{AB} = \frac{\pi^2 EI}{L_e^2}$$

$$\therefore \sqrt{2} F = \frac{\pi^2 EI}{L_e^2}$$

$$\Rightarrow F = \frac{\pi^2 EI}{\sqrt{2} L^2}$$

05. Ans: (a)

Sol: Given data:

$$L_e = L = 3 \text{ m,}$$

$$\alpha = 12 \times 10^{-6} / ^\circ\text{C,}$$

$$d = 50 \text{ mm} = 0.05 \text{ m}$$

$$\text{Buckling load, } P_e = \frac{\pi^2 EI}{L_c^2}$$

$$\therefore \frac{P_e L}{AE} = L \alpha \Delta T$$

$$\therefore \frac{\pi^2 EI \times L}{L^2 \times AE} = L \alpha \Delta T$$

$$\therefore \frac{\pi^2 \times E \times \frac{\pi}{64} \times d^4 \times L}{L^2 \times \frac{\pi}{4} d^2 \times E} = L \alpha \Delta T$$

$$\therefore \Delta T = \frac{\pi^2 \times d^2}{16 \times L^2 \times \alpha} = \frac{\pi^2 \times (0.05)^2}{16 \times 3^2 \times 12 \times 10^{-6}}$$

$$\Rightarrow \Delta T = 14.3^\circ\text{C}$$

Chapter

11

Strain Energy

01. Ans: (d)

Sol:

- Slope of the stress-strain curve in the elastic region is called modulus of elasticity.

For the given curves,

$$(\text{Modulus of elasticity})_A > (\text{Modulus of elasticity})_B$$

$$\therefore E_A > E_B$$

- The material for which plastic region is more is stress-strain curve is possessed high ductility. Thus, $D_B > D_A$.

02. Ans: (b)

Sol:

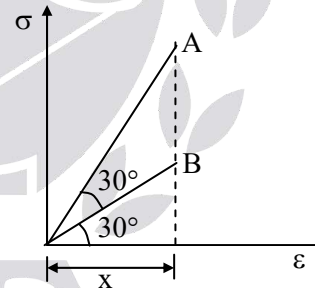

$$\frac{(SE)_A}{(SE)_B} = \frac{\text{Area under curve A}}{\text{Area under curve B}}$$

$$= \frac{\frac{1}{2} \times x \times x \tan 60^\circ}{\frac{1}{2} \times x \times x \tan 30^\circ} = \frac{3}{1}$$

03. Ans: (a)

Sol:

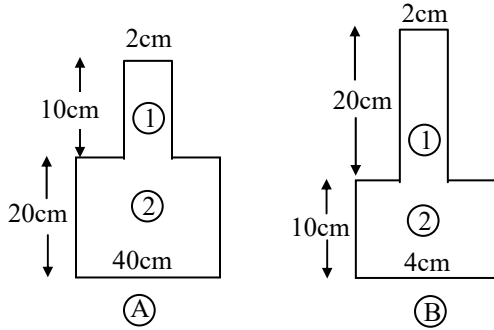

$$\frac{U_B}{U_A} = \frac{(V_1 + V_2)_B}{(V_1 + V_2)_A}$$

$$\therefore \frac{U_B}{U_A} = \frac{\left[\frac{\sigma_1^2}{2E} \times V_1 + \frac{\sigma_2^2}{2E} \times V_2 \right]_B}{\left[\frac{\sigma_1^2}{2E} \times V_1 + \frac{\sigma_2^2}{2E} \times V_2 \right]_A}$$

$$= \frac{\left[\frac{P^2}{A_1^2} \times A_1 \times L_1 + \frac{P^2 \times A_2 \times L_2}{A_2^2} \right]_B}{\left[\frac{P^2 \times A_1 \times L_1}{A_1^2} + \frac{P^2 \times A_2 \times L_2}{A_2^2} \right]_A}$$

$$\Rightarrow \frac{U_B}{U_A} = \frac{\left[\frac{L_1}{A_1} + \frac{L_2}{A_2} \right]_B}{\left[\frac{L_1}{A_1} + \frac{L_2}{A_2} \right]_A} = \frac{7.165}{4.77} = \frac{3}{2}$$

04. Ans: (c)

Sol: A_1 = Modulus of resilience

$A_1 + A_2$ = Modulus of toughness

$$A_1 = \frac{1}{2} \times 0.004 \times 70 \times 10^6 = 14 \times 10^4$$

$$A_2 = \frac{1}{2} \times (0.008 \times 50 \times 10^6) + (0.008 \times 70 \times 10^6) = 76 \times 10^4$$

$$A_1 + A_2 = (14 + 76) \times 10^4 = 90 \times 10^4$$

05. Ans: (d)

Sol: Strain energy, $U = \frac{P^2}{2A^2E} \cdot V$

$$\therefore U \propto P^2$$

Due to the application of P_1 and P_2 one after the other

$$(U_1 + U_2) \propto P_1^2 + P_2^2 \dots\dots\dots (1)$$

Due to the application of P_1 and P_2 together at the same time.

$$U \propto (P_1 + P_2)^2 \dots\dots\dots(2)$$

It is obvious that,

$$(P_1^2 + P_2^2) < (P_1 + P_2)^2$$

$$\Rightarrow (U_1 + U_2) < U$$

06. Ans: 1.5

Sol: Given data:

$$L = 100 \text{ mm}$$

$$G = 80 \times 10^3 \text{ N/mm}^2$$

$$J_1 = \frac{\pi}{32} (50)^4; \quad J_2 = \frac{\pi}{32} (26)^4$$

$$U = U_1 + U_2 = \frac{T^2 L}{2GJ_1} + \frac{T^2 L}{2GJ_2}$$

$$\Rightarrow U = 1.5 \text{ N-mm}$$

07. Ans: (a, b)

Sol: Strain energy stored in AB = $\frac{1}{2} \times P \times \delta$

$$= \frac{1}{2} \times P \times \frac{P\ell}{AE}$$

$$= \frac{P^2 L}{2AE}$$

Axial deformation of AB = $\frac{PL}{AE}$

Strain energy stored in BC,

$$U = \int_0^l \frac{M^2 dx}{2EI} \quad (M = Px)$$

$$= \int_0^l \frac{(Px)^2 dx}{2EI}$$

$$= \frac{P^2 l^3}{6EI}$$

The displacement at point B is not equal to $\frac{Pl^3}{3EI}$, since there is a hinge point C not fixed.

Chapter

12

Propped and Fixed Beams

01. Ans: (d)

Sol:

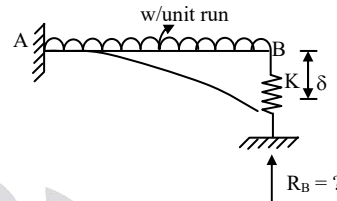

$$K = \text{Stiffness} = \frac{\text{Load}}{\text{deflection}}$$

$$\therefore K = \frac{R_B}{\delta}$$

\therefore Compatibility condition

Deflection @ B = δ

$$\therefore K = \frac{R_B}{\delta} \Rightarrow \delta = \frac{R_B}{K}$$

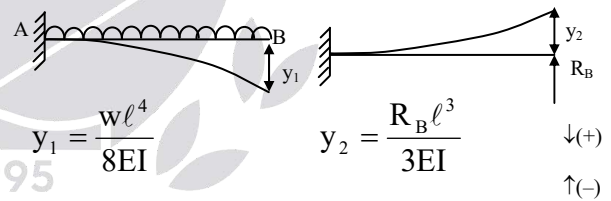

$$y_1 = \frac{wl^4}{8EI}$$

$$y_2 = \frac{R_B l^3}{3EI}$$

$$y_1 - y_2 = \delta$$

$$\therefore \frac{wl^4}{8EI} - \frac{R_B l^3}{3EI} = \delta$$

$$\frac{wl^4}{8EI} - \frac{R_B l^3}{3EI} = \frac{R_B}{K}$$

$$\frac{wl^4}{8EI} = \frac{R_B}{K} + \frac{R_B l^3}{3EI}$$

$$\frac{wl^4}{8EI} = R_B l^3 \left[\frac{1}{K l^3} + \frac{1}{3EI} \right]$$

$$\frac{wl^4}{8EI} = R_B \left[\frac{3EI + Kl^3}{3EI \times Kl^3} \right] \times l^3$$

$$\frac{wl}{8EI} = \frac{R_B}{3EI} \left[\frac{3EI + Kl^3}{Kl^3} \right]$$

$$\frac{3wl}{8} = R_B \left[\frac{3EI + Kl^3}{Kl^3} \right]$$

$$\frac{3wl}{8} = R_B \left[1 + \frac{3EI}{Kl^3} \right]$$

$$R_B = \frac{\frac{3wl}{8}}{1 + \frac{3EI}{Kl^3}}$$

02. Ans: $\frac{9pa}{8L}$

Sol:

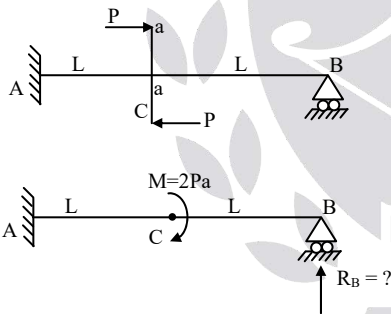

Applying, superposition principle

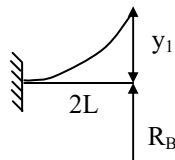

$$y_1 = \frac{R_B(2L)^3}{3EI} = \frac{8R_B L^3}{3EI}$$

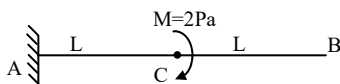

By conjugate beam method

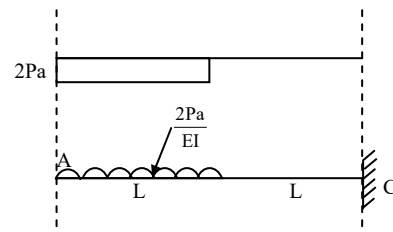

$\therefore y_c =$ deflection @ C
= B.M.D. @ C by conjugate beam

$$y_c = \frac{2Pa}{EI} \times L \times \left[L + \frac{L}{2} \right]$$

$$= \frac{2Pa}{EI} \times L \times \frac{3L}{2}$$

$$= \frac{3PaL^2}{EI}$$

Compatibility Condition ($y_B = 0$)

$$\therefore y_1 = y_c$$

$$\frac{8R_B L^3}{3EI} = \frac{3PaL^2}{EI}$$

$$R_B = \frac{9Pa}{8L} (\uparrow)$$

03. Ans: 12.51 kN

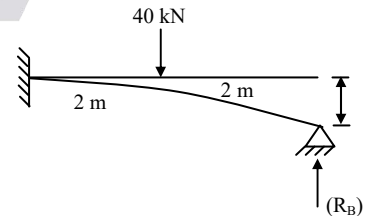

$$E = 200 \text{ GPa}$$

$$I = 2 \times 10^{+6} \text{ mm}^4$$

As per compatablity

$$\frac{(R_B)(4000)^3}{3EI} = \frac{(40 \times 10^3)(2000)^3}{3 \times EI} + \frac{40 \times 10^3 \times (2000)^2}{2EI} \times 2000 + 1 \text{mm}$$

$$\frac{R_B(2\ell)^3}{3EI} = \frac{Pa^3}{3EI} + \frac{Pa^2}{2EI}(b) + 1 \text{mm} \left[\text{use } a = b = \frac{L}{2} = 2000 \text{mm} \right]$$

where $EI = 4 \times 10^{11} \text{ N/mm}^2$

$$\therefore \frac{R_B(4000)^3}{3 \times 4 \times 10^{11}} = \frac{40 \times 10^3 \times (2000)^3}{3 \times 4 \times 10^{11}} + \frac{40 \times 10^3 \times (2000)^2}{2 \times 4 \times 10^{11}} + 1$$

$$R_B = 12.51 \text{ kN}$$

Chapter

13

Shear Centre

01. Ans: (a)

Sol:

- Shear centre is related to torsion
- On principal plane shear stress is zero
- At fixed end slope is zero.
- Middle third rule is to avoid tension in columns.

02. Ans: (b)

Sol: If the resultant force is acting through shear centre torsion developed in the c/s is zero.

03. Ans: (a), (b), (c), (d)

Chapter

14

Theories of Failure

01. Ans: (d)

Sol: $\sigma = \sigma_y = 2500 \text{ kg/cm}^2$

$$\sigma_1 = 2000 \text{ kg/cm}^2$$

$$\sigma_3 = ?$$

Maximum shear stress theory

$$\tau_{\max} = \frac{(\sigma_1 - \sigma_3)}{2} \neq \frac{\sigma_y}{2}$$

$$= \frac{2000 - \sigma_3}{2} = \frac{2500}{2}$$

$$\sigma_3 = -500 \text{ (comp)}$$

02. Ans: (b)

Sol: $D = 100 \text{ cm}$

$$P = 10 \text{ kg/cm}^2$$

$$\sigma = \sigma_y = 2000 \text{ kg/cm}^2$$

$$\text{FOS} = 4 \quad t = ?$$

Maximum Principal stress theory

$$\sigma_1 = \sigma_h = \frac{PD}{2t} \neq \sigma_y$$

$$\frac{10 \times 100}{2 \times t} = 2000$$

$$t = 2.5 \text{ mm}$$

Safe thickness of plate = $2.5 \times \text{F.O.S}$

$$= 2.5 \times 4$$

$$= 10 \text{ mm}$$

03. Ans: (b)

Sol: $\sigma_1 = 1.5 (T)$

$$\sigma_2 = \sigma (T)$$

$$\sigma_3 = -\sigma/2 (C)$$

$$\sigma_y = 2000 \text{ kg/cm}^2$$

$$\mu = 0.3$$

In which theory of failure $\sigma = 1000 \text{ kg/cm}^2$

Check

(a) Maximum principal stress theory

$$\sigma_1 = \sigma_y$$

$$1.5\sigma_1 = 2000$$

$$\sigma_1 = 1333 \text{ kg/cm}^2$$

(b) Maximum shear stress theory

$$\left(\frac{\sigma_1 - \sigma_3}{2} \right) = \frac{\sigma_y}{2}$$

$$\left(\frac{1.5\sigma + \frac{\sigma}{2}}{2} \right) = \frac{2000}{2}$$

$$\frac{4}{2}\sigma = 2000$$

$$\sigma = 1000 \text{ kg/cm}^2$$

04. Ans: (c)

Sol: $\sigma_1 = 800 \text{ kg/cm}^2$

$$\sigma_2 = 400 \text{ kg/cm}^2$$

$$\mu = 0.25$$

$$\varepsilon_1 \leq \frac{\sigma_y}{E}$$

$$\frac{\sigma_1}{E} - \mu \frac{\sigma_2}{E} - \frac{\mu\sigma_3}{E} = \frac{\sigma_y}{E}$$

$$\frac{800}{E} - 0.25 \frac{(400)}{E} = \frac{\sigma_y}{E}$$

$$\sigma_y = 800 - 100 = 700 \text{ kg/cm}^2$$

ACE