



ACE

Engineering Academy

Head Office : Sree Sindhi Guru Sangat Sabha Association, # 4-1-1236/1/A, King Koti, Abids, Hyderabad - 500001.

Ph: 040-23234418, 040-2324419, 040-2324420, 040-24750437

Hyderabad | Delhi | Bhopal | Pune | Bhubaneswar | Lucknow | Patna | Bengaluru | Chennai | Vijayawada | Vizag | Tirupati | Kukatpally | Kolkata | Ahmedabad

CIVIL ENGINEERING

BPSK PRACTICE QUESTIONS

01. A square matrix B is skew-symmetric if
(A) $B^T = -B$ (B) $B^T = B$ (C) $B^{-1} = B$ (D) $B^{-1} = B^T$
02. For a scalar function $f(x, y, z) = x^2 + 3y^2 + 2z^2$, the gradient at the point P (1, 2, -1) is
(A) $2\vec{i} + 6\vec{j} + 4\vec{k}$ (B) $2\vec{i} + 12\vec{j} - 4\vec{k}$ (C) $2\vec{i} + 12\vec{j} + 4\vec{k}$ (D) $\sqrt{56}$
03. The analytic function $f(z) = \frac{z-1}{z^2+1}$ has singularities at
(A) 1 and -1 (B) 1 and i (C) 1 and -i (D) i and -i
04. A thin walled cylindrical pressure vessel having a radius of 0.5 m and wall thickness of 25 mm is subjected to an internal pressure of 700 kPa. The hoop stress developed is
(A) 14 MPa (B) 1.4 MPa (C) 0.14 MPa (D) 0.014 MPa
05. The modulus of rupture of concrete in terms of its characteristic cube compressive strength (f_{ck}) in MPa according to IS 456:2000 is
(A) $5000 f_{ck}$ (B) $0.7 f_{ck}$ (C) $5000 \sqrt{f_{ck}}$ (D) $0.7 \sqrt{f_{ck}}$
06. In the theory of plastic bending of beams, the ratio of plastic moment to yield moment is called
(A) shape factor (B) plastic section modulus
(C) modulus of resilience (D) rigidity modulus
07. For limit state of collapse, the partial safety factors recommended by IS 456:2000 for estimating the design strength of concrete and reinforcing steel are respectively.
(A) 1.15 and 1.5 (B) 1.0 and 1.0 (C) 1.5 and 1.15 (D) 1.5 and 1.0
08. The point within the cross sectional plane of a beam through which the resultant of the external loading on the beam has to pass through to ensure pure bending without twisting of the cross-section of the beam is called
(A) moment centre (B) centroid
(C) shear centre (D) elastic center

09. The square root of the ratio of moment of inertia of the cross section to its cross sectional area is called
- (A) second moment of area (B) slenderness ration
(C) section modulus (D) radius of gyration
10. Deposit with flocculated structures is formed when
- (A) clay particles settle on sea bed (B) clay particles settle on fresh water lake bed
(C) sand particles settle on river bed (D) sand particles settle on sea bed
11. Dilatancy correction is required when a strata is
- (A) Cohesive and saturated and also has N value of SPT > 15
(B) saturated silt/fine sand and N value of SPT < 10 after the overburden correction
(C) saturated silt/fine sand and N value of SPT > 15 after the overburden correction
(D) coarse sand under dry condition and N value of SPT < 10 after the overburden correction
12. A precast concrete pile is driven with a 50 kN hammer falling through a height of 1.0 m with an efficiency of 0.6. The set value observed is 4 mm per blow and the combined temporary compression of the pile, cushion and the ground is 6 mm. As per Modified Hiley Formula, the ultimate resistance of the pile is
- (A) 3000 kN (B) 4285.7 kN (C) 8333 kN (D) 11905 kN
13. Direct step method of computation for gradually varied flow is
- (A) applicable to non-prismatic channels
(B) applicable to prismatic channels
(C) applicable to both prismatic and no-prismatic channels
(D) not applicable to both prismatic and no-prismatic channels
14. The relationship among specific yield (S_y), specific retention (S_r) and porosity (η) of an aquifer is
- (A) $S_y = S_r + \eta$ (B) $S_y = S_r - \eta$ (C) $S_y = \eta - S_r$ (D) $S_y = S_r + 2\eta$
15. The depth of flow in an alluvial channel is 1.5 m. If critical velocity ratio is 1.1 and manning's n is 0.018, the critical velocity of the channel as per Kennedy's method is
- (A) 0.713 m/s (B) 0.784 m/s (C) 0.879 m/s (D) 1.108 m/s
16. The reference pressure used in the determination of sound pressure level is
- (A) 20 μ Pa (B) 20 db (C) 10 μ Pa (D) 10 db
17. Particulate matter (fly ash) carried in effluent gases from the furnaces burning fossil fuels are better removed by
- (A) Cotton bag house filter (B) Electrostatic precipitator (ESP)
(C) Cyclone (D) Wet scrubber

18. The value of lateral friction or side friction used in the design of horizontal curve as per Indian Roads Congress guidelines is
 (A) 0.40 (B) 0.35 (C) 0.24 (D) 0.15
19. During a CBR test, the load sustained by a remolded soil specimen at 5.0 mm penetration is 50 kg. The CBR value of the soil will be
 (A) 10.0% (B) 5.0% (C) 3.6 % (D) 2.4 %
20. In quadrantal bearing system, bearing of a line varies from
 (A) 0° to 360° (B) 0° to 180° (C) 9° to 90° (D) 0° N to 90° S
21. For a scalar function $f(x, y, z) = x^2 + 3y^2 + 2z^2$, the direction derivative at the point P (1, 2, -1) in the direction of a vector $\vec{i} - \vec{j} + 2\vec{k}$ is
 (A) -18 (B) $-3\sqrt{6}$ (C) $3\sqrt{6}$ (D) 18
22. The value of the integral $\int_C \frac{\cos(2\pi z)}{(2z-1)(z-3)} dz$ (where C is a closed curve given by $|z| = 1$) is
 (A) $-\pi$ (B) $\frac{\pi i}{5}$ (C) $\frac{2\pi i}{5}$ (D) π
23. Solution of the differential equation $3y \frac{dy}{dx} + 2x = 0$ represents a family of
 (A) ellipses (B) circles (C) Parabolas (D) hyperbolas
24. Laplace transform for the function $f(x) = \cosh(ax)$ is
 (A) $\frac{a}{s^2 - a^2}$ (B) $\frac{s}{s^2 - a^2}$ (C) $\frac{a}{s^2 + a^2}$ (D) $\frac{s}{s^2 + a^2}$
25. In The solution of the following set of linear equations by Gauss elimination using partial pivoting
 $5x + y + 2z = 34;$ $4y - 3z = 12;$ and $10x - 2y + z = -4$
 the pivots for elimination of x and y are
 (A) 10 and 4 (B) 10 and 2 (C) 5 and 4 (D) 5 and -4
26. The standard normal probability function can be approximated as

$$f(x_N) = \frac{1}{1 + \exp(-1.7255x_N | x_N |^{0.12})}$$
 Where x_N = standard normal deviate. If mean and standard deviation of annual precipitation are 102 cm and 27 cm respectively, the probability that the annual precipitation will be between 90 cm and 102 cm is
 (A) 66.7% (B) 50.0% (C) 33.3% (D) 16.7%

27. Consider the following statements:
 I. On a principal plane, only normal stress acts.
 II. On a principal plane, both normal and shear stresses act.
 III. On a principal plane, only shear stress acts.
 IV. Isotropic state of stress is independent of frame of reference.
 The TRUE statements are
 (A) I and IV (B) II (C) II and IV (D) II and III
28. The degree of static indeterminacy of a rigidly jointed frame in a horizontal plane and subjected to vertical loads only, as shown in figure below, is

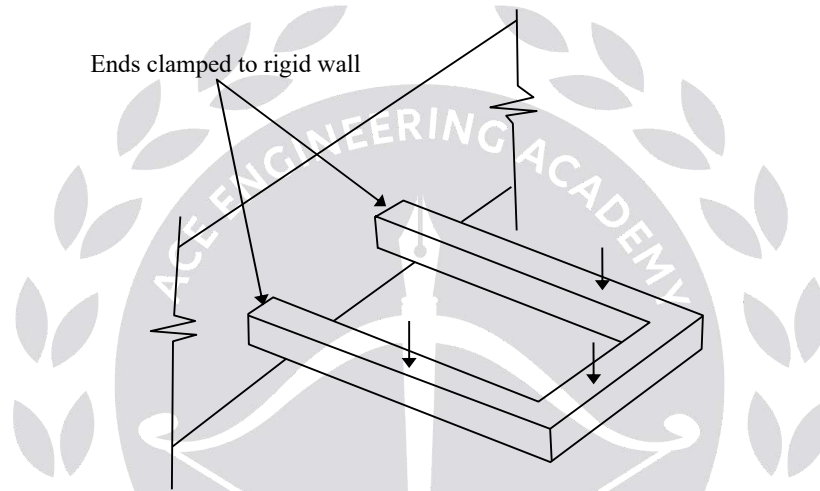

- (A) 6 (B) 4 (C) 3 (D) 1
29. A 12 mm thick plate is connected to two 8 mm thick plates. On either side through a 16 mm diameter power driven field rivet as shown in the figure below. Assuming permissible shear stress as 90 MPa and permissible bearing stress as 270 MPa in the rivet, the rivet value of the joint is
-
- (A) 56.7 kN (B) 43.29 kN (C) 36.19 kN (D) 21.65 kN
30. A hollow circular shaft has an outer diameter of 100 mm and a wall thickness of 25 mm. The allowable shear stress in the shaft is 125 MPa. The maximum torque the shaft can transmit is
 (A) 46 kN m (B) 24.5 kNm (C) 23 kN m (D) 11.5 kN m

31. Consider the following statements for a compression member:
- I. The elastic critical stress in compression increases with decrease in slenderness ratio.
 - II. The effective length depends on the boundary conditions at its ends.
 - III. The elastic critical stress in compression is independent of the slenderness ratio.
 - IV. The ratio of the effective length to its radius of gyration is called as slenderness ratio.
- The TRUE statements are
- (A) II and III (B) III and IV (C) II, III & IV (D) I, II & IV

32. Group I gives the shear force diagrams and Group II gives the diagrams of beams with supports and loading. Match the Group I with Group II.

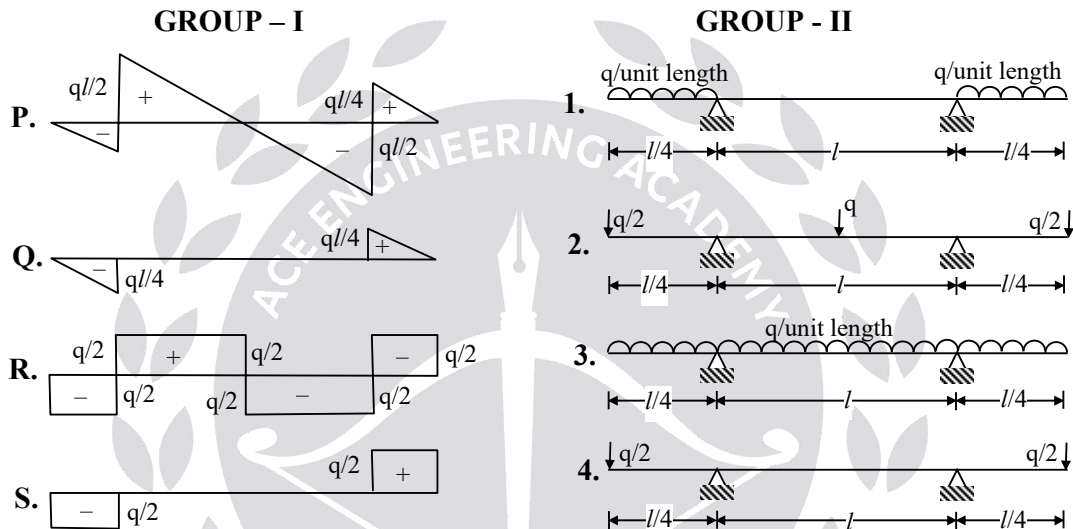

- (A) P – 3, Q – 1, R – 2, S – 4 (B) P – 3, Q – 4, R – 2, S – 1
 (C) P – 2, Q – 1, R – 4, S – 3 (D) P – 2, Q – 4, R – 3, S – 4

33. A rectangular concrete beam of width 120 mm and depth 200 mm is prestressed by pretensioning to a force of 150 kN at an eccentricity of 20 mm. The cross sectional area of the prestressing steel is 187.5 mm². Take modulus of elasticity of steel and concrete as 2.1 × 10⁵ MPa and 3.0 × 10⁴ MPa respectively. The percentage loss of stress in the prestressing steel due to elastic deformation of concrete is
- (A) 8.75 (B) 6.125 (C) 4.81 (D) 2.19

34. Column I gives a list of test methods for evaluating properties of concrete and Column II gives the list of properties.

Column I

- P. Resonant frequency test
 Q. Rebound hammer test
 R. Split cylinder test
 S. Compacting factor test

Column II

1. Tensile strength
 2. Dynamic modulus of elasticity
 3. Workability
 4. Compressive strength

The correct match of the test with the property is

- (A) P – 2, Q – 4, R – 1, S – 3 (B) P – 2, Q – 1, R – 4, S – 3
 (C) P – 2, Q – 4, R – 3, S – 1 (D) P – 4, Q – 3, R – 1, S – 2
35. The laboratory test results of a soil sample are given below:
 Percentage finer than 4.75 mm = 60
 Percentage finer than 0.075 mm = 30
 Liquid Limit = 35%
 Plastic Limit = 27%
 The soil classification is
 (A) GM (B) SM (C) GC (D) ML – MI
36. A plate load test is carried out on a 300 mm × 300 mm plate placed at 2 m below the ground level to determine the bearing capacity of a 2 m × 2 m footing placed at same depth of 2 m on a homogeneous sand deposit extending 10 mm below ground. The ground water table is 3 m below the ground level. Which of the following factor **does not** require a correction to the bearing capacity determined based on the load test?
 (A) absence of the overburden pressure during the test
 (B) Size of the palte is much smaller than the footing size
 (C) Influence of the ground water table
 (D) Settlement is recorded only over a limited period of one or two days
37. Water flows through a 100 mm diameter pipe with a velocity of 0.015 m/sec. If the kinematic viscosity of water is $1.13 \times 10^{-6} \text{ m}^2/\text{sec}$, the friction factor of the pipe material is
 (A) 0.0015 (B) 0.032 (C) 0.037 (D) 0.048
38. A rectangular open channel of width 4.5 m is carrying a discharge of 100 m³/sec. The critical depth of the channel is
 (A) 7.09 m (B) 3.69 m (C) 2.16 m (D) 1.31 m
39. Water ($\gamma_w = 9.879 \text{ kN/m}^3$) flows with a flow rate of 0.3 m³/sec through a pipe AB of 10 m length and of uniform cross section. The end 'B' is above end 'A' and the pipe makes an angle of 30° to the horizontal. For a pressure of 12 kN/m² at the end 'B', the corresponding pressure at the end 'A' is
 (A) 12.0 kN/m² (B) 17.0 kN/m² (C) 56.4 kN/m² (D) 61.4 kN/m²
40. An agricultural land of 437 ha is to be irrigated for a particular crop. The base period of the crop is 90 days and the total depth of water required by the crop is 105 cm. If a rainfall of 15 cm occurs during the base period, the duty of irrigation water is
 (A) 437 ha/cumec (B) 486 ha/cumec (C) 741 ha/cumec (D) 864 ha/cumec

41. **Column I**
- P. Coriolis effect
 Q. Fumigation
 R. Ozone layer
 S. Maximum mixing depth (mixing height)
- Column II**
1. Rotation of earth
 2. Lapse rate and vertical temperature profile
 3. Inversion
 4. Dobson
- The correct match of Column I with Column II is
- (A) P – 2, Q – 1, R – 4, S – 3 (B) P – 2, Q – 1, R – 3, S – 4
 (C) P – 1, Q – 3, R – 2, S – 4 (D) P – 1, Q – 3, R – 4, S – 2
42. A horizontal flow primary clarifier treats wastewater in which 10%, 60% and 30% of particles have settling velocities of 0.1 mm/s, 0.2 mm/s, and 1.0 mm/s respectively. What would be the total percentage of particles removed if clarifier operates at a Surface Overflow Rate (SOR) of $43.2 \text{ m}^3/\text{m}^2\cdot\text{d}$?
- (A) 43% (B) 56% (C) 86% (D) 100%
43. An aerobic reactor receives wastewater at a flow rate of $500 \text{ m}^3/\text{d}$ having a COD of 2000 mg/L. The effluent COD is 400 mg/L. Assuming that wastewater contains 80% biodegradable waste, the daily volume of methane produced by the reactor is
- (A) 0.224 m^3 (B) 0.280 m^3 (C) 224 m^3 (D) 280 m^3
44. **Column I**
- P. Grit chamber
 Q. Secondary settling tank
 R. Activated sludge process
 S. Trickling filter
- Column II**
1. Zone settling
 2. Stoke's law
 3. Aerobic
 4. Contact stabilisation
- The correct match of Column I with Column II is
- (A) P – 1, Q – 2, R – 3, S – 4 (B) P – 2, Q – 1, R – 3, S – 4
 (C) P – 1, Q – 2, R – 4, S – 3 (D) P – 2, Q – 1, R – 4, S – 3
45. Which of the following stress combinations are appropriate in identifying the critical condition for the design of concrete pavements?
- | Type of Stress | Location |
|----------------|-------------|
| P. Load | 1. Corner |
| Q. Temperature | 2. Edge |
| | 3. Interior |
- (A) P – 2, Q – 3 (B) P – 1, Q – 3 (C) P – 3, Q – 1 (D) P – 2, Q – 2
46. A crest vertical curve joints two gradients of +3% and -2% for a design speed of 80 km/h and the corresponding stopping sight distance of 120 m. The height of driver's eye and the object above the road surface are 1.20 m and 0.15 m respectively. The curve length (which is less than stopping sight distance) to be provided is
- (A) 120 m (B) 152 m (C) 163 m (D) 240 m

47. On a specific highway, the speed-density relationship follows the Greenberg's model [$v = v_f / \ln(k_j/k)$], where v_f and k_j are the free flow speed and jam density respectively. When the highway is operating at capacity, the density obtained as per this model is
 (A) $e.k_j$ (B) k_j (C) $k_j/2$ (D) k_j/e
48. A three-phase traffic signal at an intersection is designed for flows shown in the figure below. There are six groups of flows identified by the number s1 through 6. Among these 1, 3, 4 and 6 are through flows and 2 and 5 are right turning. Which phasing scheme is **not feasible**?

Combination Choice	Phase I	Phase II	Phase III
P	1, 4	2, 5	3, 6
Q	1, 2	4, 5	3, 6
R	2, 5	1, 3	4, 6
S	1, 4	2, 6	3, 5

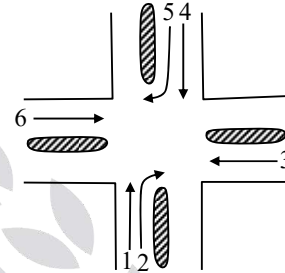

- (A) P (B) Q (C) R (D) S
49. The magnetic bearing of a line AB was $N 59^\circ 30' W$ in the year 1967, when the declination was $4^\circ 10' E$. If the present declination is $3^\circ W$, the whole circle bearing of the line is
 (A) $299^\circ 20'$ (B) $307^\circ 40'$ (C) $293^\circ 20'$ (D) $301^\circ 40'$
50. Determine the correctness or otherwise of the following Assertion (a) and the Reason (r):
 Assertion (a): Curvature correction must be applied when the sights are long.
 Reason (r): Line of collimation is not a level line but is tangential to the level line.
 (A) Both (a) and (r) are true and (r) is the correct reason for (a)
 (B) Both (a) and (r) are true but (r) is not the correct reason for (a)
 (C) Both (a) and (r) are false
 (D) (a) is false but (r) is true.

Common Data Questions

Common data for Questions 51 and 52:

Examine the test arrangement and the soil properties given below:

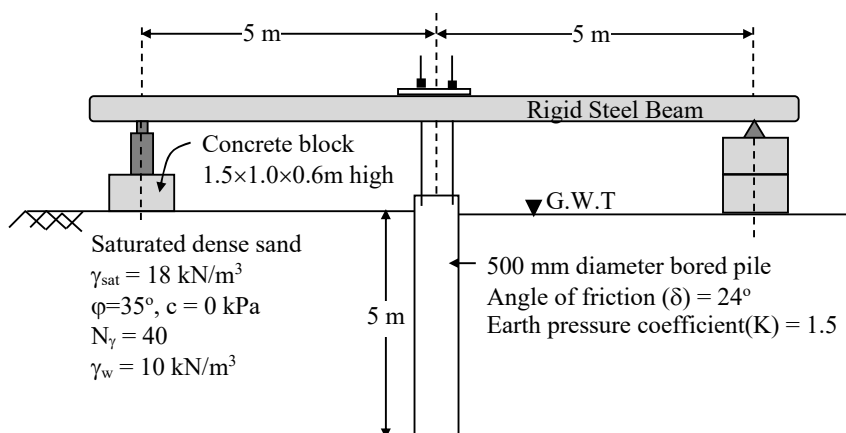

51. The maximum pressure that can be applied with a factor of safety of 3 through the concrete block, ensuring no bearing capacity failure in soil using Terzaghi's bearing capacity equation without considering the shape factor, depth factor and inclination factor is
 (A) 26.67 kPa (B) 60 kPa (C) 90 kPa (D) 120 kPa
52. The maximum resistance offered by the soil through skin friction while pulling out the pile from the ground is
 (A) 104.9 kN (B) 209.8 kN (C) 236 kN (D) 472 kN

Common Data for Questions 53 & 54:

Following chemical species were reported for water sample from a well:

Spices	Concentration (milli equivalent/L)
Chloride (Cl^-)	15
Sulphate (SO_4^{2-})	15
Carbonate (CO_3^{2-})	05
Bicarbonate (HCO_3^-)	30
Calcium (Ca^{2+})	12
Magnesium (Mg^{2+})	18
pH	8.5

53. Total hardness in mg/L as CaCO_3 is
 (A) 1500 (B) 2000 (C) 3000 (D) 5000
54. Alkalinity present in the water in mg/L as CaCO_3 is
 (A) 250 (B) 1500 (C) 1750 (D) 5000

Common Data for Questions 55 and 56:

One hour triangular unit hydrograph of a watershed has the peak discharge of $60 \text{ m}^3/\text{sec}$. cm at 10 hours and time base of 30 hours. The ϕ index is 0.4 cm per hour and base flow is $15 \text{ m}^3/\text{sec}$.

55. The catchment area of the watershed is
 (A) 3.24 km^2 (B) 32.4 km^2 (C) 324 km^2 (D) 3240 km^2
56. If there is rainfall of 5.4 cm in 1 hour, the ordinate of the flood hydrograph at 15th hour is
 (A) $225 \text{ m}^3/\text{sec}$ (B) $240 \text{ m}^3/\text{sec}$ (C) $249 \text{ m}^3/\text{sec}$ (D) $258 \text{ m}^3/\text{sec}$

Linked Answer Questions
Statement for Linked Answer Question 57 and 58:

In the cantilever beam PQR shown in figure below, the segment PQ has flexural rigidity EI and the segment QR has infinite flexural rigidity.

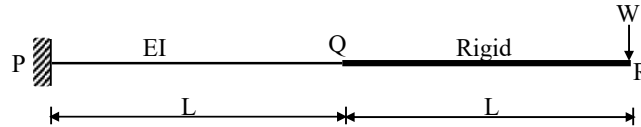

57. The deflection and slope of the beam at “Q” are respectively

- (A) $\frac{5WL^3}{6EI}$ and $\frac{3WL^2}{2EI}$ (B) $\frac{WL^3}{3EI}$ and $\frac{WL^3}{2EI}$
 (C) $\frac{WL^3}{2EI}$ and $\frac{WL^2}{EI}$ (D) $\frac{WL^3}{3EI}$ and $\frac{3WL^2}{2EI}$

58. The deflection of the beam at ‘R’ is

- (A) $\frac{8WL^3}{EI}$ (B) $\frac{5WL^3}{6EI}$ (C) $\frac{7WL^3}{3EI}$ (D) $\frac{8WL^3}{6EI}$

Linked Answer Questions 59 and 60:

59. A saturated undisturbed sample from a clay strata has moisture content of 22.22% and specific weight of 2.7. Assuming $\gamma_w = 10 \text{ kN/m}^3$, the void ratio and the saturated unit weight of the clay, respectively are

- (A) 0.6 and 16.875 kN/m^3 (B) 0.3 and 20.625 kN/m^3
 (C) 0.6 and 20.625 kN/m^3 (D) 0.3 and 16.975 kN/m^3

60. Using the properties of the clay layer derived from the above question, the consolidation settlement of the same clay layer under a square footing (neglecting its self weight) with additional data shown in the figure below (assume the stress distribution as 1H:2V from the edge of the footing and $\gamma_w = 10 \text{ kN/m}^3$) is

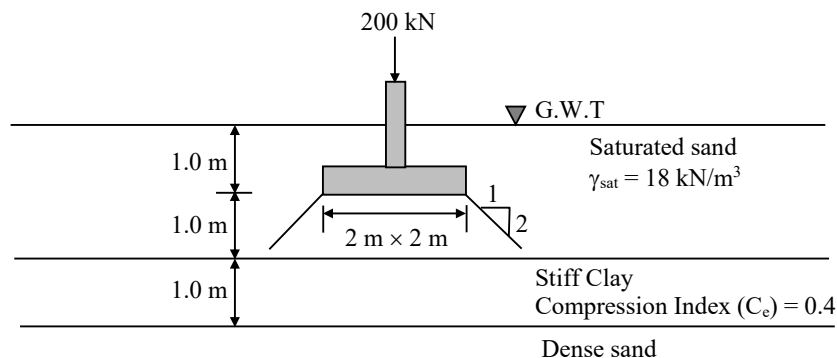

- (A) 32.78 mm (B) 61.75 mm (C) 79.5 mm (D) 131.13 mm