

GATE | PSUs



MECHANICAL ENGINEERING

Heat Transfer

Text Book : Theory with worked out Examples
and Practice Questions

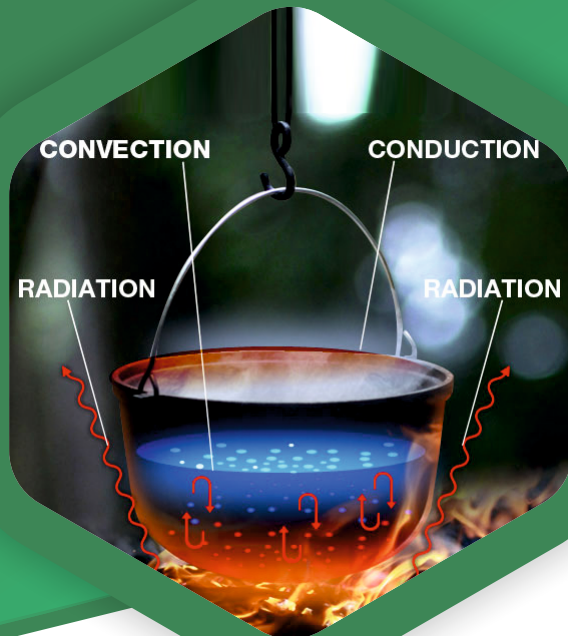

HYDERABAD | AHMEDABAD | DELHI | BHOPAL | PUNE | BHUBANESWAR | BANGALORE | LUCKNOW
PATNA | CHENNAI | VISAKHAPATNAM | VIJAYAWADA | TIRUPATHI | KOLKATA

Heat Transfer

Solutions for Text Book Practice Questions

Chapter

1

Conduction

01. Ans: (b)

Sol: Given data:

$$\begin{aligned} T_{si} &= 600^\circ\text{C}; & T_{so} &= 20^\circ\text{C}; \\ k_A &= 20 \text{ W/mK}; & k_C &= 50 \text{ W/mK}; \\ L_A &= 0.30 \text{ m} & L_B &= 0.15 \text{ m}; \\ L_C &= 0.15 \text{ m}, & h &= 25 \text{ W/m}^2\text{K} \end{aligned}$$

Thermal circuit:

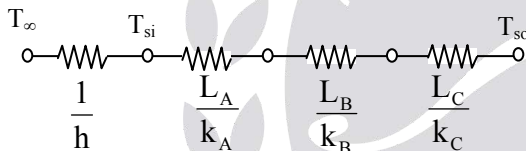

Energy balance:

Convective heat transfer at the wall surface
= conductive heat transfer through the wall

$$\begin{aligned} \frac{T_\infty - T_{si}}{\frac{1}{h}} &= \frac{T_{si} - T_{so}}{\frac{L_A}{k_A} + \frac{L_B}{k_B} + \frac{L_C}{k_C}} \\ \frac{800 - 600}{\frac{1}{25}} &= \frac{600 - 20}{\frac{0.30}{20} + \frac{0.15}{k_B} + \frac{0.15}{50}} \end{aligned}$$

$$\Rightarrow k_B = 1.53 \text{ W/mK}$$

02. Ans: (a)

Sol: Given data:

$$\begin{aligned} L_1 &= L_2 = 0.01; \\ k_1 &= k_2 = 16.6 \text{ W/mK} \end{aligned}$$

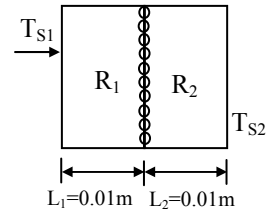

Thermal circuit:

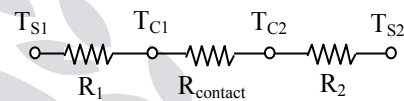

$$R_1 = R_2 = \frac{L}{k} = \frac{0.01 \text{ m}^2\text{K}}{16.6 \text{ W}}$$

$$q_1 = \frac{T_{S1} - T_{S2}}{2R_1 + R_{\text{constant}}} = \frac{100}{2 \left[\frac{0.01}{16.6} \right] + 15 \times 10^{-4}}$$

$$q = 36971.046$$

$$q = \frac{T_{C1} - T_{C2}}{R_{\text{contact}}}$$

$$T_{C1} - T_{C2} = 55.45^\circ\text{C}$$

03. Ans: (c)

Sol: Given data:

$$\begin{aligned} T_1 &= 5^\circ\text{C}, & T_2 &= 25^\circ\text{C}, \\ k &= 10 \text{ W/mK}, & R_{\text{contact}} &= 0.01 \text{ mK/W} \end{aligned}$$

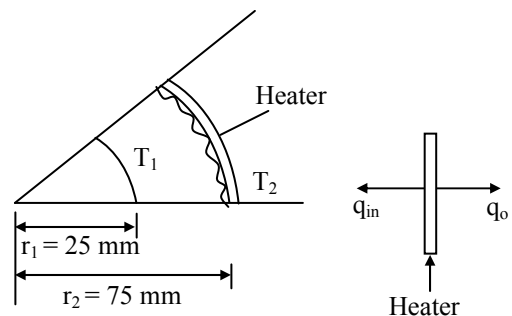

$$q_{in} = \frac{T_2 - T_1}{R_{contact} + R_{cond}}$$

$$= \frac{25 - 5}{0.01 + \frac{\ln\left(\frac{75}{25}\right)}{2\pi \times 10 \times 1}} = 727.67 \text{ W/m}$$

$$q_{out} = \frac{T_2 - T_\infty}{\frac{1}{h_o A_o}}$$

$$= \frac{25 + 10}{\frac{1}{100 \times 2\pi \times 0.075 \times 1}} = 1649.33 \text{ W/m}$$

Heater Power = Total Heat Loss

$$= q_{in} + q_{out} = 2377 \text{ W/m}$$

04. Ans: (d)

Sol: Given data:

$$T_1 = 100^\circ\text{C},$$

$$r_m = 0.075 \text{ m}$$

$$T_2 = 45^\circ\text{C}$$

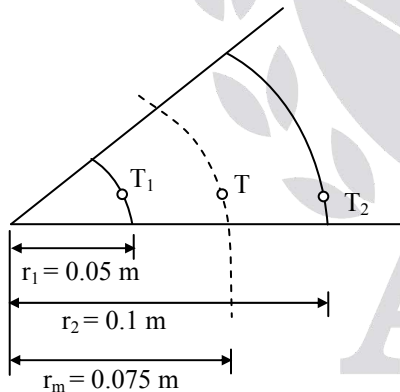

$$\frac{T_m - T_1}{T_2 - T_1} = \frac{\frac{1}{r_1} - \frac{1}{r_m}}{\frac{1}{r_1} - \frac{1}{r_2}}$$

$$\frac{T_m - 100}{45 - 100} = \frac{\frac{1}{0.05} - \frac{1}{0.075}}{\frac{1}{0.05} - \frac{1}{0.1}} \Rightarrow T_m = 63.3^\circ\text{C}$$

05. Ans: (485 K)

Sol: Given data:

Volumetric heat generation rate

$$q_g = 0.3 \text{ MW/m}^3$$

$$k = 25 \text{ W/mK};$$

$$T_\infty = 92^\circ\text{C};$$

$$h_o = 500 \text{ W/m}^2\text{K}$$

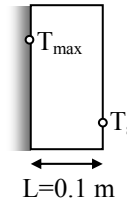

Energy balance:

$$Q_{in} + Q_{gen} - Q_{out} = Q_{stored}$$

$$Q_{gen} = Q_{out}$$

$$q_g A' L = h A' (T_s - T_\infty)$$

$$0.3 \times 10^6 \times 0.1 = 500 \times (T_s - 92)$$

$$\Rightarrow T_s = 152^\circ\text{C}$$

$$T_{max} - T_s = \frac{q_g L^2}{2k}$$

(q_g = heat generation per unit volume)

$$T_{max} = T_s + \frac{q_g L^2}{2k}$$

$$T_{max} = 152 + \frac{0.3 \times 10^6 \times (0.1)^2}{2 \times 25}$$

$$T_{max} = 212^\circ\text{C} = 485 \text{ K}$$

06. Ans: (b)

Sol: Given data:

$$q_g = 2.6 \times 10^6 \text{ W/m}^3$$

$$k = 45 \text{ W/m}^\circ\text{C}$$

$$T_\infty = 0^\circ\text{C}$$

$$h = 1200 \text{ W/m}^2\text{C}$$

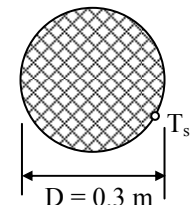

Temperature difference between center line and surface of the sphere

$$T_{\max} - T_s = \frac{q_d R^2}{6k}$$

$$T_{\max} = T_s + \frac{q_d R^2}{6k}$$

$$= 108.33 + \frac{2.6 \times 10^6 \times (0.15)^2}{6 \times 45}$$

$$T_{\max} = 325^\circ\text{C}$$

Energy balance:

$$Q_{\text{in}} + Q_{\text{gen}} - Q_{\text{out}} = Q_{\text{stored}}$$

$$Q_{\text{gen}} = Q_{\text{out}}$$

$$q_g \frac{4}{3} \pi R^3 = h 4 \pi R^2 (T_s - T_\infty)$$

$$T_s - T_\infty = \frac{q_g R}{3h}$$

$$T_s = T_\infty + \frac{q_g R}{3h}$$

$$T_s = 0 + \frac{2.6 \times 10^6 \times 0.15}{3 \times 1200}$$

$$T_s = 108.33^\circ\text{C}$$

07. Ans: (b)

Sol:

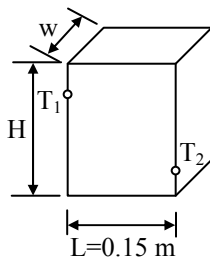

Given data:

$$T_1 = 500 \text{ K}, \quad H = 1.5 \text{ m}$$

$$T_2 = 350 \text{ K}, \quad W = 0.6 \text{ m}, \quad L = 0.15 \text{ m}$$

$$T_{\text{avg}} = \frac{T_1 + T_2}{2} = \frac{500 + 350}{2} = 425^\circ\text{C}$$

$$k_T = k_o [1 + \beta T]$$

$$k_{\text{avg}} = k_o [1 + \beta T_{\text{avg}}]$$

$$k_{\text{avg}} = 25 [1 + (8.7 \times 10^{-4}) \times 425]$$

$$k_{\text{avg}} = 34.24 \text{ W/mK}$$

$$Q = \frac{\frac{T_1 - T_2}{L}}{k_{\text{avg}} A}$$

$$= \frac{500 - 350}{34.24 \times 1.5 \times 0.6} = 30.816 \times 10^3 = \omega$$

$$Q = 30.816 \text{ kW}$$

08. Ans: (c)

Sol:

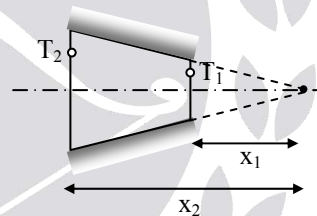

Given data:

$$T_1 = 400 \text{ K}, \quad T_2 = 600 \text{ K}$$

$$D = ax, \quad a = 0.25$$

$$x_1 = 0.05 \text{ m}, \quad x_2 = 0.25 \text{ m}$$

$$A = \frac{\pi}{4} D^2 = \frac{\pi}{4} a^2 x^2$$

$$Q = -kA \frac{dT}{dx}$$

$$Q = -k \frac{\pi}{4} a^2 x^2 \frac{dT}{dx}$$

$$Q \frac{dx}{x^2} = -\frac{\pi k a^2}{4} dT$$

$$Q \int_{x_1}^{x_2} \frac{dx}{x^2} = -\frac{\pi k a^2}{4} \int_{T_1}^{T_2} dT$$

$$Q \left[\frac{-1}{x} \right]_{x_1}^{x_2} = \frac{-\pi k a^2}{4} (T_2 - T_1)$$

$$Q \left[\frac{-1}{x_2} + \frac{1}{x_1} \right] = \frac{-\pi k a^2}{4} (T_2 - T_1)$$

$$Q = \frac{-\pi k a^2 (T_2 - T_1)}{4 \left[\frac{1}{x_1} - \frac{1}{x_2} \right]}$$

$$= \frac{-\pi \times 3.46 \times (0.25)^2 (600 - 400)}{4 \left[\frac{1}{0.05} - \frac{1}{0.25} \right]}$$

$Q = -2.12 \text{ W}$ (– sign indicates the direction of heat transfer)

09. Ans: (d)

Sol: Given data:

Thermal conductivity of insulation
 $(k_{in}) = 0.5 \text{ W/mK}$

Heat transfer coefficient of surrounding air
 $(h_o) = 20 \text{ W/m}^2\text{K}$

Thickness of insulation for maximum heat transfer = $r_c - r = \frac{k_{in}}{h_o} - r$

$$= \frac{0.5}{20} - 0.01 = 15 \text{ mm}$$

10. Ans: (a)

Sol: Given data:

Thermal conductivity of insulation
 $(k_{in}) = 0.1 \text{ W/mK}$

Heat transfer coefficient of surrounding air
 $(h_o) = 10 \text{ W/m}^2\text{K}$

Radius $(r) = 1.5 \text{ cm}$,

Critical radius of insulation $(r_c) = \frac{k_{in}}{h_o}$

$$= \frac{0.1}{10} = 0.01 \text{ m} = 1 \text{ cm}$$

$\therefore r > r_c$

\therefore Adding the insulation will always reduce the heat transfer rate.

11. Ans: (c)

Sol: Given data:

Radius $(r) = 1 \text{ mm}$,

Thermal conductivity of insulation
 $(k_{in}) = 0.175 \text{ W/mK}$

Heat transfer coefficient of surrounding air
 $(h_o) = 125 \text{ W/m}^2\text{K}$

Thickness = $0.2 \text{ mm} = r_{new} - r$

$$r_{new} = 1.2 \text{ mm}$$

Critical radius of insulation $(r_c) = \frac{k_{in}}{h_o}$

$$= \frac{0.175}{125} = 1.4 \text{ mm}$$

$\therefore r_{new} < r_c$

\therefore Addition of further insulation, heat transfer rate increases first then decreases.

12. Ans: (b)

Sol: Given data:

Thermal conductivity of insulation
 $(k_{in}) = 0.4 \text{ W/mK}$

Heat transfer coefficient of surrounding air
 $(h_o) = 10 \text{ W/m}^2\text{K}$

Critical radius of insulation for the

$$\text{sphere } (r_c) = \frac{2k_{in}}{h_o} = \frac{2 \times 0.04}{10} = 8 \text{ mm}$$

$$\text{Critical diameter } (d_c) = 2r_c = 16 \text{ mm}$$

13. Ans: (b)

Sol:

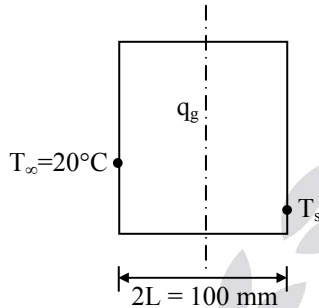

Volumetric heat generation rate

$$(q_g) = 1000 \text{ W/m}^3$$

$$T_x = a(L^2 - x^2) + b$$

$$T_x = 0.05 = 10(10.05^2 - 0.05^2) + 30$$

$$T_s = 30^\circ\text{C}$$

$$T_\infty = 20^\circ\text{C}$$

$$\frac{\partial T}{\partial x} = a(0 - 2x)$$

$$\frac{\partial^2 T}{\partial x^2} = -2a = -2 \times 10 = -20$$

1-D heat conduction equation with internal heat generation:

$$\frac{\partial^2 T}{\partial x^2} + \frac{q_g}{k} = \frac{1}{\alpha} \frac{\partial T}{\partial t}$$

$$-20 + \frac{1000}{K} = 0 \quad \left(\text{for steady state, } \frac{\partial T}{\partial t} = 0 \right)$$

$$\frac{1000}{k} = 20$$

$$k = 50 \text{ W/mK}$$

Energy balance:

$$-k \frac{\partial T}{\partial x} \Big|_{x=+0.05\text{m}} = h[T_s - T_\infty]$$

$$-50[a \times (-2x)]_{x=0.05} = h[30 - 20]$$

$$-50[10(-2 \times 0.05)] = h \times 10$$

$$\Rightarrow h = 5 \text{ W/m}^2\text{K}$$

14. Ans: (c)

Sol: Given data:

$$\Delta V = 10 \text{ V,}$$

$$\rho = 70 \times 10^{-8} \text{ m,}$$

$$D = 3.2 \times 10^{-3} \text{ m,}$$

$$r = 1.6 \times 10^{-3} \text{ m,}$$

$$T_s = 93^\circ\text{C,}$$

$$T = 22.5 \text{ W/mK,}$$

$$L = 0.3 \text{ m}$$

Resistance

$$(R) = \frac{\rho L}{A_c} = \frac{70 \times 10^{-8} \times (0.3)}{\frac{\pi}{4} (3.2 \times 10^{-3})^2} = 0.02611 \Omega$$

$$I = \frac{\Delta V}{R} = \frac{10}{0.02511} = 382.97 \text{ Amp}$$

$$Q_g = \Delta VI = 10 \times 382.97$$

$$Q_g = 3829.75 \text{ W}$$

$$q_g = \frac{Q_g}{\text{volume}} = 1.587 \times 10^9 \text{ W/m}^3$$

Temperature difference between center line and surface of the cylindrical wire

$$T_{\max} - T_s = \frac{q_g R^2}{4k} = 138.14^\circ\text{C}$$

Chapter

2

Transient Heat Conduction

01. Ans: (b)

Sol: Given data:

$$D = 1.2 \text{ cm}, \quad R = 0.6 \text{ cm},$$

$$T_o = 900^\circ\text{C}, \quad T_\infty = 30^\circ\text{C},$$

$$h = 125 \text{ W/m}^2\text{C}, \quad c_p = 480 \text{ J/kg}$$

$$L_c = \frac{R}{3} = 0.2 \text{ cm}, \quad T = 850^\circ\text{C},$$

$$\therefore Bi = \frac{hL_c}{k} < 0.1$$

\(\therefore\) Lumped method can be applied.

$$\ln\left[\frac{T - T_\infty}{T_o - T_\infty}\right] = \frac{-ht}{\rho c_p L_c}$$

$$\Rightarrow t = 3.67 \text{ sec}$$

02. Ans: (c)

Sol: Given data:

$$\rho = 8500 \text{ kg/m}^3, \quad c_p = 320 \text{ J/kgK}$$

$$h = 65 \text{ W/m}^2\text{K}, \quad k = 35 \text{ W/mK}$$

$$d = 1.2 \text{ mm}$$

$$\frac{T_o - T}{T_o - T_\infty} = 0.99$$

$$\therefore Bi = \frac{hL_c}{k} < 0.1$$

\(\therefore\) Lumped method can be applied.

$$\frac{T_o - T}{T_o - T_\infty} = 1 - e^{\frac{-ht}{\rho c_p L_c}}$$

$$0.99 = 1 - e^{\frac{-ht}{\rho c_p L_c}}$$

$$e^{\frac{-ht}{\rho c_p L_c}} = 1 - 0.99 = 0.01$$

$$\frac{-ht}{\rho c_p L_c} = \ln(0.01)$$

$$t = \frac{\rho c_p L_c}{h} \ln(0.01)$$

$$\Rightarrow t = 38.54 \text{ sec}$$

03. Ans: (d)

Sol:

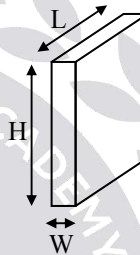

Given data:

$$T_o = 25^\circ\text{C}; \quad T_\infty = 600^\circ\text{C}$$

$$Q_{\text{act}} = 0.75 Q_{\text{max}}$$

$$L_c = \frac{V}{A_s} = \frac{HWL}{2HU} = \frac{W}{2} = \frac{0.05}{2} = 0.025$$

$$m_c [T - T_o] = 0.75 [m_c (T_\infty - T_o)]$$

$$T - 25 = 0.75 (600 - 25)$$

$$\Rightarrow T = 456.25^\circ\text{C}$$

$$Bi = \frac{hL_c}{k} = \frac{100 \times 0.025}{231} = < 0.1$$

$$\therefore Bi = \frac{hL_c}{k} < 0.1$$

\(\therefore\) Lumped method can be applied.

$$\ln\left[\frac{T - T_\infty}{T_o - T_\infty}\right] = \frac{-ht}{\rho c_p L_c}$$

$$\Rightarrow t = 967.34 \text{ sec}$$

04. Ans: (b)

Sol: According to lumped capacity analysis:

$$\ln \left[\frac{T - T_{\infty}}{T_0 - T_{\infty}} \right] = \frac{-t}{\tau^*}$$

$$\ln \left[\frac{\frac{T_0 + T_{\infty}}{2} - T_{\infty}}{T_0 - T_{\infty}} \right] = \frac{-t}{\tau^*}$$

$$\ln \left[\left(\frac{T_0 + T_{\infty}}{2} \right) \frac{1}{T_0 - T_{\infty}} \right] = \frac{-t}{\tau^*}$$

$$\ln \left(\frac{1}{2} \right) = \frac{-t}{\tau^*}$$

$$\ln(2) = \frac{-t}{\tau^*}$$

$$\Rightarrow t = \tau^* \ln(2)$$

05. Ans: (c)

Sol: Given data:

$$m = 500 \text{ g} = 0.5 \text{ kg};$$

$$T_0 = 530^\circ\text{C};$$

$$T = 430^\circ\text{C};$$

$$T_{\infty} = 30^\circ\text{C}$$

According to lumped capacity analysis

$$\ln \left[\frac{T - T_{\infty}}{T_0 - T_{\infty}} \right] = \frac{-t}{\tau^*},$$

$$\ln \left[\frac{430 - 30}{530 - 30} \right] = \frac{-10}{\tau^*} \quad \dots\dots\dots (1)$$

$$\ln \frac{400}{500} = \frac{-10}{\tau^*}$$

$$\Rightarrow \tau^* = 44.81 \text{ s}$$

Temperature after next 10 s,

$$T_0 = 430^\circ\text{C}; \quad t = 10 \text{ sec};$$

$$\ln \left[\frac{T - T_{\infty}}{T_0 - T_{\infty}} \right] = \frac{-t}{\tau^*}$$

$$\frac{T - 30}{430 - 30} = e^{\frac{-10}{\tau^*}} \quad \dots\dots\dots (2)$$

$$T = 30 + 400 \times e^{-10/44.81}$$

$$\Rightarrow T = 350^\circ\text{C}$$

06. Ans: 12.05 K/min

Sol: Given data:

$$D = 0.05 \text{ m};$$

$$T_0 = 900^\circ\text{C}, \quad T_{\infty} = 30^\circ\text{C}$$

$$\rho = \frac{m}{V}$$

$$m = \rho V = \rho \frac{4}{3} \pi R^3$$

$$= 7800 \times \frac{4}{3} \times \pi (0.025)^3 = 0.510 \text{ kg}$$

Energy balance:

Decrease in internal energy = Convective heat transfer from the surface

$$-mc \frac{dT}{dt} = hA_s (T_0 - T_{\infty})$$

$$0.510 \times 2000 \times \frac{dT}{dt} = 30 \times 4\pi (0.025)^2 \times (900 - 30)$$

$$\frac{dT}{dt} = 0.2 \text{ K/sec}$$

$$\frac{dT}{dt} = 12.05 \text{ K/min}$$

$$\begin{aligned} \% \text{ error} &= \frac{1 - \tanh(mL)}{\tanh h(mL)} \\ &= \frac{1}{\tanh(mL)} - 1 = 63.48\% \end{aligned}$$

03. Ans: (c)

Sol: Given data:

$$D = 5 \text{ mm}, \quad L = 50 \text{ mm}, \quad \eta = 0.65$$

$$\frac{\epsilon}{\eta} = \frac{Q_{\text{Fin}}}{Q_{\text{without fin}}} \times \frac{Q_{\text{max}}}{Q_{\text{Fin}}}$$

$$\frac{\epsilon}{\eta} = \frac{Q_{\text{max}}}{Q_{\text{without fin}}}$$

$$= \frac{hA_s(T_o - T_\infty)}{hA_c(T_o - T_\infty)}$$

$$\text{Surface area } (A_s) = \pi DL$$

$$\text{Cross-sectional area } (A_c) = \frac{\pi D^2}{4}$$

$$\frac{\epsilon}{\eta} = \frac{\pi DL}{\frac{\pi D^2}{4}}$$

$$\frac{\epsilon}{\eta} = 4 \left(\frac{L}{D} \right)$$

$$\frac{\epsilon}{0.65} = 4 \left(\frac{50}{5} \right)$$

$$\Rightarrow \epsilon = 26$$

04. Ans: 420%

Sol: Heat transfer rate for very long fin:

$$Q = kA_c m \theta_o$$

$$= \sqrt{hpkA_c} \theta_o = \sqrt{h \times \pi D \times k \times \frac{\pi}{4} D^2} \theta_o$$

$$Q \propto D^{3/2}$$

$$\frac{Q_2}{Q_1} = \frac{(D_2)^{3/2}}{(D_1)^{3/2}} = \frac{(3D_1)^{3/2}}{(D_1)^{3/2}} = 5.1962$$

$$\% \text{ increase in Heat Transfer} = \frac{Q_2 - Q_1}{Q_1}$$

$$= \frac{Q_2}{Q_1} - 1$$

$$= 5.1962 - 1$$

$$= 4.19 \approx 420\%$$

05. Ans: (c)

Sol: Given data:

$$k_A = 70 \text{ W/mK},$$

$$x_A = 0.15 \text{ m},$$

$$x_B = 0.075 \text{ m}$$

Temperature variation for long fin:

$$\frac{T_o - T_\infty}{T - T_\infty} = e^{mx}$$

$$m = \sqrt{\frac{ph}{kA_c}} = \sqrt{\frac{4h}{kD}}$$

$$m \propto \sqrt{\frac{1}{k}} \quad (\text{for the same diameter and same environment})$$

For the same temperatures

$$m_A x_A = m_B x_B$$

$$\frac{x_2}{x_1} = \frac{m_1}{m_2} = \sqrt{\frac{k_B}{k_A}}$$

$$\frac{k_B}{k_A} = \left(\frac{x_B}{x_A} \right)^2$$

$$\frac{k_B}{70} = \left(\frac{0.075}{0.15} \right)^2$$

$$\Rightarrow k_B = 17.5 \text{ W/mK}$$

06. Ans: (d)
Sol: Given data:

$$a = 5 \times 10^{-3} \text{ m} = 5 \text{ mm,}$$

$$T_o = 400^\circ\text{C,}$$

$$T_\infty = 50^\circ\text{C,}$$

$$k = 54 \text{ W/mK,}$$

$$L = 0.08 \text{ m,}$$

$$h = 90 \text{ W/m}^2\text{K,}$$

$$\frac{P}{A_c} = \frac{3a}{\sqrt{\frac{3}{4}a^2}} = \frac{4\sqrt{3}}{a}$$

$$m = \sqrt{\frac{hP}{kA_c}} = \sqrt{\frac{4\sqrt{3}h}{ka}}$$

$$m = \sqrt{\frac{4\sqrt{3} \times 90}{54 \times 5 \times 10^{-3}}} = 48.05$$

$$mL = 3.844$$

$$L_c = L + \frac{A_c}{P} = 0.08 + \frac{a}{4\sqrt{3}}$$

$$= 0.08 + \frac{5 \times 10^{-3}}{4\sqrt{3}}$$

$$= 0.08072 \text{ m}$$

Heat transfer rate from the fin:

$$Q_{\text{Fin}} = kA_c m \theta_o \tanh(mL_c)$$

$$= 54 \times \left(\frac{\sqrt{3}}{4} \times 0.005^2 \right) \times 48.05 \times (400 - 50)$$

$$\times \tanh(48.05 \times 0.08072)$$

$$Q_{\text{Fin}} = 9.82 \text{ W}$$

07. Ans: (c)
Sol: Given data:

$$k = 30 \text{ W/mK,}$$

$$D = 0.01 \text{ m,}$$

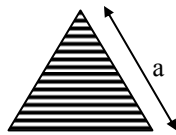

$$L = 0.05 \text{ m,}$$

$$T_\infty = 65^\circ\text{C,}$$

$$h = 50 \text{ W/m}^2\text{K,}$$

$$T_o = 98^\circ\text{C}$$

$$mL = \sqrt{\frac{4h}{kD}} L = \sqrt{\frac{4 \times 50}{30 \times 0.01}} \times 0.05 = 1.2909$$

Temperature variation for insulated fin tip

$$\frac{T - T_\infty}{T_o - T_\infty} = \frac{\cosh(mL - x)}{\cosh mL}$$

$$x = L, \quad T = T_L$$

$$\frac{T_L - T_\infty}{T_o - T_\infty} = \frac{1}{\cosh mL}$$

$$T_L = T_\infty + \frac{T_o - T_\infty}{\cosh(mL)}$$

$$T_L = 65 + \frac{98 - 65}{\cosh(1.29)}$$

$$T_L = 81.87^\circ\text{C}$$

08. Ans: (b)

Sol: $\frac{h}{mk} < 1$

$$\frac{h}{\sqrt{\frac{ph}{kA_c}} \times k} < 1$$

$$\sqrt{\frac{hA_c}{pk}} < 1$$

$$\sqrt{\frac{pk}{hA_c}} > 1$$

 Effectiveness (ϵ) > 1

Using the fin will increase the heat transfer rate because effectiveness of the fin is greater than unity.

09. Ans: (a)

Sol: Given data:

$$k = 200 \text{ W/m}^\circ\text{C}, h = 15 \text{ W/m}^2\text{ }^\circ\text{C}, L = 1 \text{ cm}$$

Cross-sectional area of fin

$$(A_c) = 0.5 \times 0.5 \text{ mm}^2$$

$$T_o = 80^\circ\text{C},$$

$$T_\infty = 40^\circ\text{C}$$

$$m = \sqrt{\frac{ph}{kA_c}}$$

$$= \sqrt{\frac{4 \times 0.0005 \times 15}{200 \times 0.0005 \times 0.0005}} = 24.49$$

$$mL = 24.49 \times 0.01 = 0.2449$$

$$\tanh(mL) = 0.240$$

Heat transfer rate from fin with insulated tip

$$Q_{\text{Fin}} = kA_c m \theta_o \tanh(mL)$$

$$= 200 \times (0.5 \times 10^{-3})^2 \times 24.5 \times (80 - 40) \times 0.240$$

$$Q_{\text{Fin}} = 0.01176$$

$$\text{No. of fin} = \frac{Q_{\text{total}}}{Q_{\text{Fin}}} = \frac{1}{0.01176} = 85$$

10. Ans: 191.5 W/mK

Sol: Given data:

$$T_x = 150^\circ\text{C},$$

$$T_{x+15\text{cm}} = 95^\circ\text{C},$$

$$T_\infty = 30^\circ\text{C}$$

$$D = 25 \text{ mm},$$

$$h = 20 \text{ W/m}^2\text{ }^\circ\text{C}$$

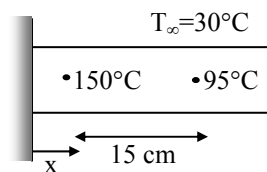

Temperature variation for long fin

$$\frac{T - T_\infty}{T_o - T_\infty} = e^{-mx}$$

$$\frac{150 - 30}{T_o - 30} = e^{-mx} \dots\dots\dots (1)$$

$$\frac{95 - 30}{T_o - 30} = e^{-m(x+15)} \dots\dots\dots (2)$$

From equation (1) and (2) we get

$$\ln \left[\frac{150 - 30}{95 - 30} \right] = m \Delta x$$

$$\ln \left[\frac{150 - 30}{95 - 30} \right] = \sqrt{\frac{4h}{Dk}} \times 0.15$$

$$\Rightarrow k = 191.5 \text{ W/mK}$$

Chapter

4

Convection

01. Ans: 40 W/m²K

Sol:

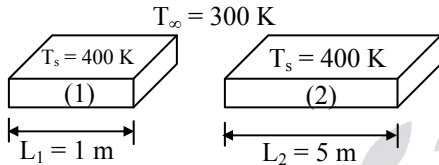

Given that:

$$V_1 = 100 \text{ m/s,}$$

$$V_2 = 20 \text{ m/s,}$$

$$q_1 = 20,000 \text{ W/m}^2$$

$$\begin{aligned} \text{Heat transfer from object (1)} &= h_1 (T_s - T_\infty) \\ 20000 &= h_1 (400 - 300) \\ h_1 &= 200 \text{ W/m}^2\text{K} \end{aligned}$$

Reynold's number for object (1)

$$Re_1 = \frac{V_1 L_1}{\nu} = \frac{100 \times 1}{\nu} = \frac{100}{\nu}$$

Reynold's number for object (2)

$$Re_2 = \frac{V_2 L_2}{\nu} = \frac{20 \times 5}{\nu} = \frac{100}{\nu}$$

Since, $\nu_1 = \nu_2$ (for the same fluid)

$$\therefore Re_1 = Re_2$$

\therefore Prandtl number is the property of the fluid.

$$\therefore Pr_1 = Pr_2$$

Nusselt number (Nu) = $f [Re.Pr]$

$$Nu_1 = Nu_2$$

$$\frac{h_1 L_1}{k_1} = \frac{h_2 L_2}{k_2}$$

$$\frac{h_2}{h_1} = \frac{L_1}{L_2}$$

$$h_2 = h_1 \times \frac{L_1}{L_2} = 200 \times \frac{1}{5} = 40 \text{ W/m}^2\text{K}$$

02. Ans: (d)

Sol: Given data:

$$Pr = 0.7, \quad T_\infty = 400 \text{ K}$$

$$T_s = 300 \text{ K,} \quad \frac{u_\infty}{\nu} = 5000/\text{m}$$

$$k = 0.263 \text{ W/mK}$$

$$\frac{T - T_s}{T_\infty - T_s} = 1 - e^{\left(-Pr \frac{u_\infty y}{\nu}\right)}$$

$$T = T_s + (T_\infty - T_s) \left[1 - e^{\left(-Pr \frac{u_\infty y}{\nu}\right)} \right]$$

$$\frac{dT}{dy} = (T_\infty - T_s) \left[0 - e^{\left(-Pr \frac{u_\infty y}{\nu}\right)} \right] \left(-Pr \frac{u_\infty}{\nu} \right)$$

$$\begin{aligned} \left. \frac{dT}{dy} \right|_{y=0} &= (T_\infty - T_s) (-1) \left(-Pr \frac{u_\infty}{\nu} \right) \\ &= (T_\infty - T_s) \left(Pr \frac{u_\infty}{\nu} \right) \end{aligned}$$

Heat transfer rate = Heat conduction just adjacent on the surface (i.e. at $y = 0$)

$$q = -k \left. \frac{dT}{dy} \right|_{y=0}$$

$$q = -k (T_\infty - T_s) \left(Pr \frac{u_\infty}{\nu} \right)$$

$$q = 0.0263 (300 - 400) [0.7 \times 5000]$$

$$q = 9205 \text{ W/m}^2$$

03. Ans: (c)
Sol: Given data:

$$u_{(y)} = Ay + By^2 - cy^3$$

$$T_{(y)} = D + Ey + Fy^2 - Gy^3$$

$$\frac{du}{dy} = A + 2By - 3cy^2$$

$$\left. \frac{du}{dy} \right|_{y=0} = A$$

According to Newton's law of viscosity:

$$\begin{aligned} \text{Wall shear stress } (\tau_s) &= \mu \left. \frac{du}{dy} \right|_{y=0} \\ &= \mu A \end{aligned}$$

$$\text{Skin friction coefficient } (c_f) = \frac{\tau_s}{\frac{1}{2} \rho u_\infty^2}$$

$$c_f = \frac{2\mu A}{\rho u_\infty^2}$$

$$c_f = \frac{2\nu A}{u_\infty^2} \quad \left(\nu = \frac{\mu}{\rho} \right)$$

For the temperature profile:

$$\frac{dT}{dy} = E + 2Fy - 3Gy^2$$

$$\left. \frac{dT}{dy} \right|_{y=0} = E$$

Energy balance:

Conduction heat transfer in the fluid adjacent to the wall (i.e. at $y = 0$) = convective heat transfer inside the fluid.

$$-k \left. \frac{dT}{dy} \right|_{y=0} = h(T_s - T_\infty)$$

$$h = \frac{-k \left. \frac{dT}{dy} \right|_{y=0}}{T_s - T_\infty} = \frac{-kE}{T_s - T_\infty}$$

$$h = \frac{kE}{T_\infty - D}$$

 $(T_s = D, \text{ from the temperature profile})$
04. Ans: (b)
Sol: Given data:

$$\dot{m} = 2 \text{ kg/s}, \quad D = 0.04 \text{ m}, \quad T_i = 25^\circ\text{C},$$

$$T_o = 75^\circ\text{C}, \quad T_s = 100^\circ\text{C},$$

$$h = 6916 \text{ W/m}^2\text{K},$$

$$c_p = 4181 \text{ J/kg.K.}$$

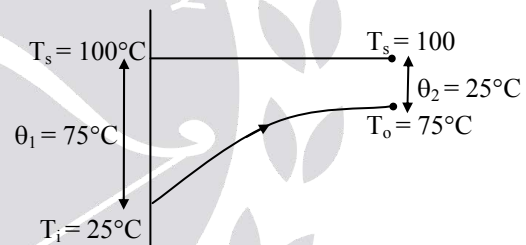

$$\text{LMTD} = \frac{\theta_1 - \theta_2}{\ln\left(\frac{\theta_1}{\theta_2}\right)} = \frac{75 - 25}{\ln\left(\frac{75}{25}\right)} = 45.51^\circ\text{C}$$

 Heat transfer rate = $h \times A \times \text{LMTD}$

$$\dot{m} c_p (T_o - T_i) = 6916 \times \pi \times 0.04 \times L \times 45.51$$

$$2 \times 4181 \times (75 - 25) = 39554 L$$

$$\Rightarrow L \approx 10.6 \text{ m}$$

05. Ans: (b)
Sol: Given data:

$$D = 30 \text{ mm},$$

$$T_\infty = 20^\circ\text{C},$$

$$h = 11 \text{ W/m}^2\text{K},$$

$$L = 1 \text{ m},$$

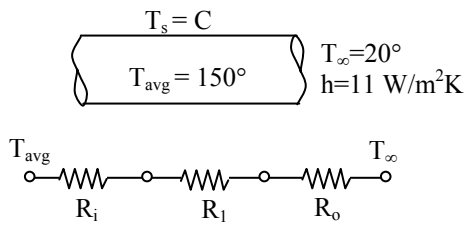

For laminar fully developed with constant wall temperature condition:

$$Nu = 3.66$$

$$\frac{hD}{k} = 3.66$$

$$h = 3.66 \text{ k/D}$$

$$h = 3.66 \times \frac{0.133}{0.03} = 16.22 \text{ W/m}^2\text{K}$$

$$q = \frac{T_{\text{avg}} - T_{\infty}}{\frac{1}{h_i} + \frac{1}{h_o}} = \frac{150 - 20}{\frac{1}{16.22} + \frac{1}{11}} = 80.3 \text{ W/m}^2$$

06. Ans: (c)

Sol: In constant wall temperature condition, mean temperature of the fluid continuously changes in the direction of fluid flow. The temperature difference between surface temperature and mean fluid temperature decreases in the direction of flow.

Therefore, mean temperature difference is considered as log mean temperature difference in calculation.

For the temperature profile, refer to the diagram in Solution of Q. No. 04

07. Ans: (b)

Sol: Nusselt number (Nu) = 4.36 for laminar flow through tubes with constant heat flux condition.

Nusselt number (Nu) = 3.36 for laminar flow through tubes with constant wall temperature condition.

For the same tube and fluid,

$$h_{\text{constant heat flux}} > h_{\text{constant wall temperature}}$$

08. Ans: (d)

Sol: Given data:

$$Pr = 3400,$$

$$k = 0.145 \text{ W/mK},$$

$$\nu = 288 \times 10^{-6} \text{ m}^2\text{sec},$$

$$\alpha = 0.847 \times 10^{-7} \text{ m}^2/\text{s},$$

$$\beta = 0.7 \times 10^{-3}/\text{K},$$

$$T_{\infty} = 5^{\circ}\text{C},$$

$$T_s = 70^{\circ}\text{C},$$

$$D = 0.4 \text{ m}.$$

$$\begin{aligned} \text{Characteristic length } (L_c) &= \frac{A_s}{P} = \frac{\frac{\pi}{4} D^2}{\pi D} \\ &= \frac{D}{4} = \frac{0.4}{4} = 0.1 \text{ m} \end{aligned}$$

$$\text{Grashoff number, } (Gr) = \frac{g\beta\Delta TL_c^3}{\nu^2}$$

$$Gr = \frac{9.81 \times 0.70 \times 10^{-3} \times 65 \times (0.1)^3}{(288 \times 10^{-6})^2}$$

$$Gr = 5381.401$$

$$\begin{aligned} Ra &= Gr.Pr = 5381.401 \times 3400 \\ &= 18.29 \times 10^6 \end{aligned}$$

$$\text{Nusselt number (Nu)} = \frac{\bar{h}L_c}{k} = 0.15(\text{Ra})^{1/3}$$

$$= \frac{\bar{h} \times 0.1}{0.145} = 0.15(18.29 \times 10^6)^{1/3}$$

$$\bar{h} = 57.312 \text{ W/m}^2\text{K}$$

Heat transfer rate, (Q) = hA (T_s-T_∞)

$$Q = 57.312 \times \frac{\pi}{4} (0.4)^2 \times (70 - 5)$$

$$Q = 468.13 \text{ W}$$

09. Ans: 12.70 W/m²K

Sol: Given data:

$$\rho = 1.204 \text{ kg/m}^3,$$

$$c_p = 1007 \text{ J/kg.K},$$

$$\text{Pr} = 0.7309,$$

$$F_D = 0.86 \text{ N},$$

$$T_\infty = 20^\circ\text{C},$$

$$u_\infty = 7 \text{ m/s}$$

$$\text{Area (A)} = 2[2 \times 3] = 12 \text{ m}^2$$

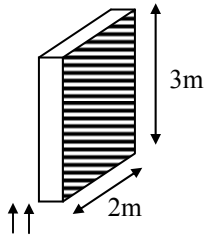

$$\text{Skin friction coefficient (} c_f) = \frac{F_D}{\frac{1}{2} \rho A u_\infty^2}$$

$$c_f = \frac{2F_D}{\rho A u_\infty^2} = \frac{2 \times 0.86}{12 \times 1.204 \times 7^2} = 2.43 \times 10^{-3}$$

According to Reynold's – Colburn analogy:

$$\text{St.Pr}^{2/3} = \frac{c_f}{2}$$

$$\text{St}(0.7309)^{2/3} = \frac{2.43 \times 10^{-3}}{2}$$

$$\text{St} = \frac{h}{\rho u_\infty c_p} = 1.5 \times 10^{-3}$$

$$h = 12.70 \text{ W/m}^2\text{K}$$

10. Ans: (c)

Sol: The variation of heat transfer coefficient (h) in the direction of fluid flow over a flat plate is shown in figure below.

$$\text{As, } h \propto \frac{1}{\sqrt{x}}$$

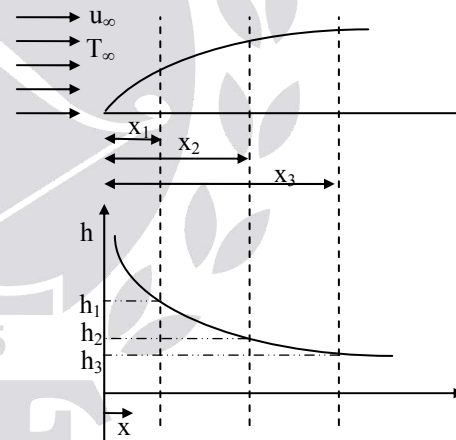

From the figure $h_1 > h_2 > h_3$

According to Newton's law of cooling,

$$\text{Heat flux (} q) = h\Delta t$$

$$q \propto h$$

$$q_1 > q_2 > q_3$$

The maximum local heat flux = q_1

(i.e. at $x = x_1$)

11. Ans: (a)
Sol: Given data:

$$L = 3 \text{ m,}$$

$$h_x = 0.7 + 13.6x - 3.4x^2$$

Average heat transfer coefficient

$$(\bar{h}) = \frac{1}{L} \int_0^L h_x dx$$

$$\bar{h} = \frac{1}{3} \int_0^3 (0.7 + 13.6x - 3.4x^2) dx$$

$$\bar{h} = \frac{1}{3} \left[0.7x + \frac{13.6x^2}{2} - \frac{3.4x^3}{3} \right]_0^3$$

$$\bar{h} = \frac{1}{3} \left[0.7(3) + \frac{13.6(3)^2}{2} - \frac{3.4(3)^3}{3} \right]$$

$$\bar{h} = 0.7 + \frac{13.6 \times 3}{2} - \frac{3.4 \times 3^2}{3}$$

$$\bar{h} = 10.9 \text{ W/m}^2\text{K}$$

 Heat transfer coefficient at $x = L = 3 \text{ m}$

$$h_{x=L=3} = 0.7 + 13.6(3) - 3.4(3)^2$$

$$h_{x=L} = 10.9 \text{ W/m}^2\text{K}$$

$$\frac{\bar{h}}{h_{x=L=3\text{m}}} = \frac{10.9}{10.9} = 1$$

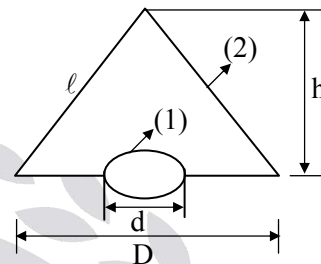
Chapter
5
Radiation
01. Ans: (c)
Sol:

$$A_1 F_{12} = A_2 F_{21} \quad \& \quad F_{12} = 1$$

$$F_{21} = \frac{A_1}{A_2}$$

$$F_{21} = \frac{\frac{\pi d^2}{4}}{\left(\frac{\pi \times D \times l}{2}\right)} = \frac{\frac{\pi d^2}{4}}{\frac{\pi \times D}{2} \times \sqrt{\frac{D^2}{4} + h^2}}$$

$$= \frac{d^2}{2D \sqrt{D^2 + 4h^2}} = \frac{d^2}{D \sqrt{D^2 + 4h^2}}$$

02. Ans: (a)
Sol: Given data:

$$\epsilon_1 = 0.5, \quad \epsilon_2 = 0.9,$$

$$T_1 = 600 \text{ K,} \quad T_2 = 400 \text{ K}$$

Net heat exchange between two long parallel plates,

$$\frac{Q}{A} = \frac{\sigma(T_1^4 - T_2^4)}{\frac{1}{\epsilon_1} + \frac{1}{\epsilon_2} - 1}$$

$$= \frac{5.67 \times 10^{-8} (600^4 - 400^4)}{\frac{1}{0.5} + \frac{1}{0.9} - 1} = 2.79 \text{ kW/m}^2$$

03. Ans: 792.16 K

Sol: Given data:

$$d = 0.05 \text{ m}, \quad k = 15 \text{ W/mK}$$

$$D = 0.06 \text{ m}, \quad q_g = 20 \times 10^3 \text{ W/m}^3$$

$$T_2 = 773 \text{ K}, \quad \epsilon_1 = \epsilon_2 = 0.2$$

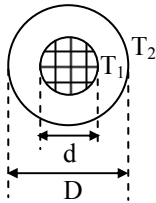

Total heat generated

$$(Q_g) = q_g \frac{\pi}{4} d^2 L = 12.5\pi L$$

$$Q_g = \frac{A_1 \sigma (T_1^4 - T_2^4)}{\frac{1}{\epsilon_1} + \left(\frac{D_1}{D_2}\right) \left(\frac{1}{\epsilon_2} - 1\right)}$$

$$12.5\pi L = \frac{\pi d L \times \sigma (T_1^4 - 773^4)}{\frac{1}{0.2} + \left(\frac{50}{60}\right) \left(\frac{1}{0.2} - 1\right)}$$

$$12.5 = \frac{0.05 \times \sigma (T_1^4 - 773^4)}{\frac{1}{0.2} + \left(\frac{50}{60}\right) \left(\frac{1}{0.2} - 1\right)}$$

$$\Rightarrow T_1 = 792.16 \text{ K}$$

04. Ans: (c)

Sol: $D_1 = 0.8 \text{ m}$,

$$D_2 = 1.2 \text{ m},$$

$$\epsilon_1 = \epsilon_2 = 0.05,$$

$$T_1 = 95 \text{ K},$$

$$T_2 = 280 \text{ K},$$

$$h_{fg} = 2.13 \times 10^5 \text{ J/kg}$$

Net heat transfer,

$$Q = -\dot{m} h_{fg} = \frac{A_1 \sigma (T_1^4 - T_2^4)}{\frac{1}{\epsilon_1} + \left(\frac{D_1}{D_2}\right)^2 \left(\frac{1}{\epsilon_2} - 1\right)}$$

$$-\dot{m} \times 2.13 \times 10^5 = \frac{\pi (0.8)^2 \times 5.67 \times 10^{-8} \times (95^4 - 280^4)}{\frac{1}{0.05} + \left(\frac{0.8}{1.2}\right)^2 \left(\frac{1}{0.05} - 1\right)}$$

$$\therefore \dot{m} = 1.1913 \times 10^{-4} \text{ kg/s} = 0.4108 \text{ kg/hr}$$

05. Ans: (d)

Sol: Given data:

$$\epsilon_1 = \epsilon_2 = 0.8,$$

$$Q_{\text{without shield}} = 10 Q_{\text{with shield}}$$

$$\frac{Q_{\text{with shield}}}{Q_{\text{without shield}}} = \frac{\frac{\sigma (T_1^4 - T_2^4)}{\frac{1}{\epsilon_1} + \frac{1}{\epsilon_2} + \frac{2N}{\epsilon_s} - (N+1)}}{\frac{\sigma (T_1^4 - T_2^4)}{\frac{1}{\epsilon_1} + \frac{1}{\epsilon_2} - 1}}$$

$$\frac{Q_{\text{with shield}}}{Q_{\text{without shield}}} = \frac{\frac{1}{\epsilon_1} + \frac{1}{\epsilon_2} - 1}{\frac{1}{\epsilon_1} + \frac{1}{\epsilon_2} + \frac{2N}{\epsilon_s} - (N+1)}$$

$$10 = \frac{\frac{1}{0.8} + \frac{1}{0.8} - 1}{\frac{1}{0.8} + \frac{1}{0.8} + \frac{2}{\epsilon_s} - 2}$$

(Number of shield (N) = 1)

$$\epsilon_s = 0.138$$

06. Ans: (c)
Sol: Given data:

$$G = 300 \text{ W/m}^2, \quad \epsilon = 0.4, \quad \alpha = 0.3$$

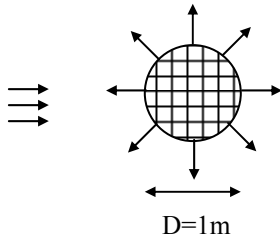

$$\alpha G A_{\text{projected}} = \epsilon E_b A$$

$$0.3 \times 300 \times \frac{\pi}{4} D^2 = 0.04 \times \sigma \times T^4 \times \pi D^2$$

$$0.3 \times 300 \times \frac{\pi}{4} (1)^2 = 0.04 \times 5.67 \times 10^{-8} \times T^4 \times \pi (1)^2$$

$$\Rightarrow T = 315.6 \text{ K}$$

07. Ans: (c)
Sol: Given data:

$$L = 1.5 \times 10^{11} \text{ m}, \quad R_{\text{SUN}} = 7 \times 10^8 \text{ m},$$

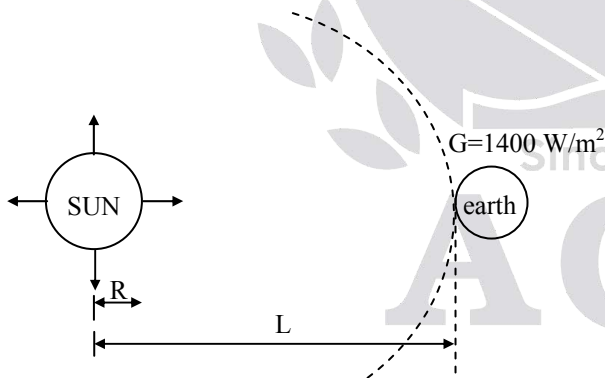
Energy balance:

$$E_b \times A_{\text{SUN}} = G \times A_{\text{Hemisphere}}$$

$$\sigma T_{\text{SUN}}^4 \times 4\pi R^2 = G \times 4\pi L^2$$

$$T_{\text{SUN}}^4 = \left(\frac{L}{R}\right)^2 \frac{G}{\sigma}$$

$$T_{\text{SUN}} = 5802.634 \approx 5800 \text{ K}$$

08. Ans: (a)
Sol: Given data:

$$J = 5000 \text{ W/m}^2,$$

$$T_1 = 350 \text{ K},$$

$$T_{\infty} = 300 \text{ K},$$

$$h = 40 \text{ W/m}^2\text{K},$$

$$\alpha = 0.4$$

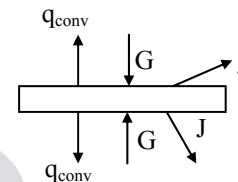

$$\begin{aligned} \text{Convective heat transfer } (q_{\text{conv}}) &= h(T_s - T_{\infty}) \\ &= 40(350 - 300) \\ &= 2000 \text{ W/m}^2 \end{aligned}$$

Energy balance:

$$Q_{\text{in}} + Q_{\text{gen}} - Q_{\text{out}} = Q_{\text{stored}}$$

$$Q_{\text{in}} - Q_{\text{out}} = 0 \quad (Q_{\text{stored}} = 0 \text{ and } Q_{\text{gen}} = 0)$$

$$2G - [2J + 2q_{\text{conv}}] = 0$$

$$2G - [2 \times 5000 + 2 \times 2000] = 0$$

$$G = 7000 \text{ W/m}^2$$

 Leaving energy (J) = $\rho G + E + \tau G$

$$J = (\rho + \tau) G + E$$

$$J = (1 - \alpha) G + E$$

$$J = (1 - 0.40) \times 7000 + \epsilon E_b$$

$$5000 = 0.6 \times 7000 + \epsilon \times 5.67 \times 10^{-8} \times (350)^4$$

$$\Rightarrow \epsilon = 0.940$$

09. Ans: (d)
Sol: Black body emission does not depend on the size of the object.

10. Ans: (b)
Sol: Given data:

$$T_w = 533 \text{ K}, \quad T_{tc} = 1066 \text{ K},$$

$$\epsilon = 0.5, \quad \bar{h} = 114 \text{ W/m}^2\text{K}$$

Energy balance:

 Heat transfer by convection = Heat transfer
 by radiation

$$q_{\text{conv}} = q_{\text{rad}}$$

$$\bar{h}(T_{\text{air}} - T_{tc}) = \epsilon \sigma (T_{tc}^4 - T_w^4)$$

$$114(T_{\text{air}} - 1066) = 0.5 \times 5.67 \times 10^{-8} (1066^4 - 533^4)$$

$$\Rightarrow T_{\text{air}} = 1367 \text{ K}$$

11. Ans: (a)
Sol:

$$T_{\text{sky}} = -30^\circ\text{C},$$

$$h = 4.36 \text{ W/m}^2\text{K}$$

$$T_s = 25^\circ\text{C}, \quad T_\infty = 0^\circ\text{C}$$

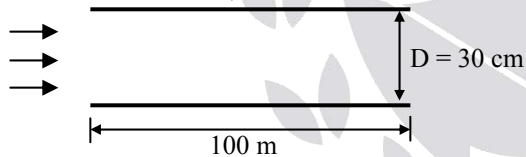
 Power required by resistance heater = Heat
 loss by convection from the surface + Heat
 loss by radiation from surface

$$P = hA(T_s - T_\infty) + \epsilon \sigma A_s(T_s^4 - T_{\text{sky}}^4)$$

$$= 4.36 \times \pi \times D \times L(25 - 0) + 0.8 \times 5.67 \times 10^{-8} \times \pi \times D \times L(298^4 - 243^4)$$

$$= 4.36 \times \pi \times 0.3 \times 100(25 - 0) + 0.8 \times 5.67 \times 10^{-8} \times \pi \times 0.3 \times 100(298^4 - 243^4)$$

$$= 29080.64 \text{ W}$$

$$P = 29.08 \text{ kW}$$

Chapter
6
Heat Exchangers
01. Ans: (d)
Sol: Given that:

$$T_{h1} = 70^\circ\text{C}, \quad T_{c1} = 30^\circ\text{C}$$

$$T_{h2} = 40^\circ\text{C}, \quad T_{c2} = 50^\circ\text{C}$$

$$\Delta T_1 = T_{h1} - T_{c2} = 20$$

$$\Delta T_2 = T_{h2} - T_{c1} = 10$$

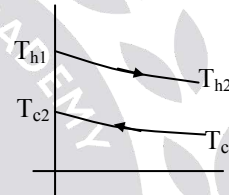

Log Mean Temperature Difference

$$(\text{LMTD}) = \frac{\Delta T_1 - \Delta T_2}{\ln \left[\frac{\Delta T_1}{\Delta T_2} \right]} = \frac{20 - 10}{\ln \left(\frac{20}{10} \right)} = 14.42^\circ\text{C}$$

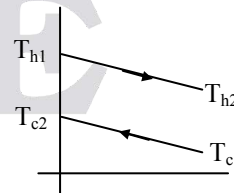
02. Ans: (c)
Sol:

$$\text{LMTD} = 20^\circ\text{C}, \quad T_{c1} = 20^\circ\text{C}, \quad T_{h1} = 100^\circ\text{C}$$

$$\dot{m}_c = 2\dot{m}_h \quad c_h = 2c_c,$$

$$C_h = \dot{m}_h c_h = 2\dot{m}_h c_c$$

$$C_c = \dot{m}_c c_c = 2\dot{m}_h c_c$$

When $C = \frac{C_{\min}}{C_{\max}} = 1$, Temperature profile

will be linear for the counter flow heat exchanger and the mean temperature difference between hot fluid and cold fluid will be same at every section.

$$\text{LMTD} = \Delta T_1 = \Delta T_2$$

$$\text{LMTD} = \Delta T_1 = T_{h1} - T_{c2}$$

$$20 = 100 - T_{c2}$$

$$T_{c2} = 100 - 20 = 80^\circ\text{C}$$

03. Ans: 0.9

Sol: This is the counter flow type of heat exchanger because exit temperature of cold fluid is greater than that of hot fluid.

$$T_{h1} - T_{h2} = 200 - 110 = 90^\circ\text{C}$$

$$T_{c2} - T_{c1} = 125 - 100 = 25^\circ\text{C}$$

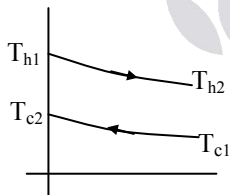

Energy balance:

Heat released by hot fluid = heat received by cold fluid

$$\dot{m}_h c_h (T_{h1} - T_{h2}) = \dot{m}_c c_c (T_{c2} - T_{c1})$$

$$\dot{m}_h c_h \times 90 = \dot{m}_c c_c \times 25$$

From the above equation $\dot{m}_c c_c > \dot{m}_h c_h$

$$\begin{aligned} \text{Effectiveness } (\epsilon) &= \frac{Q_{\text{act}}}{Q_{\text{max}}} = \frac{\dot{m}_h c_h (T_{h1} - T_{h2})}{\dot{m}_h c_h (T_{h1} - T_{c1})} \\ &= \frac{T_{h1} - T_{h2}}{T_{h1} - T_{c1}} = \frac{90}{200 - 100} \\ &= \frac{90}{100} = 0.9 \end{aligned}$$

04. Ans: (c)

Sol: Given data:

$$\dot{m}_h = 3.5 \text{ kg/s}, \quad T_{h1} = 80^\circ\text{C},$$

$$c_c = 4180 \text{ J/kg}^\circ\text{C}, \quad U_i = 250 \text{ W/m}^2\text{C}$$

$$c_h = 2560 \text{ J/kg}^\circ\text{C}, \quad T_{h2} = 40^\circ\text{C},$$

$$T_{c1} = 20^\circ\text{C}, \quad T_{c2} = 55^\circ\text{C}$$

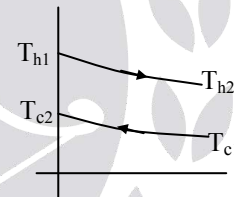

$$\Delta T_1 = T_{h1} - T_{c2} = 25$$

$$\Delta T_2 = T_{h2} - T_{c1} = 20^\circ$$

Log Mean Temperature Difference

$$(\text{LMTD}) = \frac{\Delta T_1 - \Delta T_2}{\ln \left[\frac{\Delta T_1}{\Delta T_2} \right]} = \frac{25 - 20}{\ln \left(\frac{25}{20} \right)} = 22.40^\circ\text{C}$$

Heat transfer rate

$$(Q) = \dot{m}_h c_h (T_{h1} - T_{h2}) = U_i \times A_i \times \text{LMTD}$$

$$35 \times 2560 (80 - 40) = 250 \times A_i \times 22.4$$

$$A_i = 64 \text{ m}^2$$

05. Ans: (a)
Sol: Given data:

$$T_{h1} = T_{h2} = 75^\circ\text{C},$$

$$\dot{m}_h = 2.7 \text{ kg/s}$$

$$T_{c1} = 21^\circ\text{C},$$

$$T_{c2} = 28^\circ\text{C},$$

$$A = 24 \text{ m}^2,$$

$$\Delta T_1 = T_{h1} - T_{c1} = 54^\circ\text{C}$$

$$\Delta T_2 = T_{h2} - T_{c2} = 47^\circ\text{C}$$

Log Mean Temperature Difference (LMTD)

$$= \frac{\Delta T_1 - \Delta T_2}{\ln\left(\frac{\Delta T_1}{\Delta T_2}\right)} = \frac{54 - 47}{\ln\left(\frac{54}{47}\right)} = 50.149^\circ\text{C}$$

Heat transfer rate

$$(Q) = \dot{m}_h \times h_{fg} = U \times A \times \text{LMTD}$$

$$2.7 \times 255.7 \times 10^3 = U \times 24 \times 50.419$$

$$\Rightarrow U = 571 \text{ W/m}^2\text{C}$$

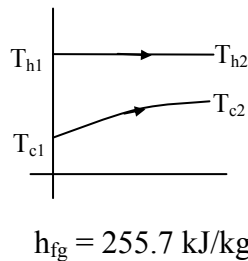

$$h_{fg} = 255.7 \text{ kJ/kg}$$

06. Ans: (c)
Sol: $T_{h1} = 150^\circ\text{C}, T_{c1} = 25^\circ\text{C}$

$$T_{h2} = 80^\circ\text{C}, T_{c2} = 60^\circ\text{C}$$

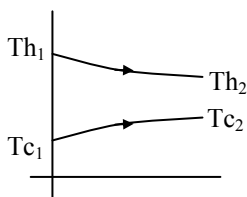

$$\Delta T_1 = T_{h1} - T_{c1} = 125$$

$$\Delta T_2 = T_{h2} - T_{c2} = 20$$

$$\text{LMTD} = \frac{\Delta T_1 - \Delta T_2}{\ln\left(\frac{\Delta T_1}{\Delta T_2}\right)} = \frac{125 - 20}{\ln\left(\frac{125}{20}\right)} = 57.29^\circ\text{C}$$

Energy balance:

Heat released by hot fluid = heat received by cold fluid

$$\dot{m}_h c_h (T_{h1} - T_{h2}) = \dot{m}_c c_c (T_{c2} - T_{c1})$$

$$\dot{m}_h c_h (150 - 80) = \dot{m}_c c_c (60 - 25)$$

$$\dot{m}_h c_h \times 70 = \dot{m}_c c_c \times 35$$

From the above equation

$$\dot{m}_c c_c > \dot{m}_h c_h \Rightarrow C_{\min} = \dot{m}_h c_h$$

Heat transfer rate (Q)

$$\dot{m}_h c_h (T_{h1} - T_{h2}) = U \times A \times \text{LMTD}$$

$$C_{\min} (T_{h1} - T_{h2}) = U \times A \times \text{LMTD}$$

$$\text{NTU} = \frac{UA}{C_{\min}} = \frac{T_{h1} - T_{h2}}{\text{LMTD}} = \frac{70}{57.29} = 1.22$$

07. Ans: (c)
Sol: Given data:

$$T_{c1} = 20^\circ\text{C},$$

$$T_{h1} = 80^\circ\text{C},$$

$$\dot{m}_c = 20 \text{ kg/s},$$

$$\dot{m}_h = 10 \text{ kg/s},$$

$$c_h = c_c = 4.2 \times 10^3 \text{ J/kg.K},$$

$$\dot{m}_h c_h = C_{\min}$$

Case - I, For parallel flow heat exchanger:

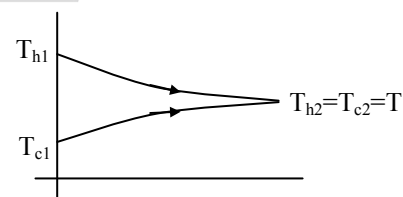
Energy balance:

Heat released by hot fluid = heat received by cold fluid

$$\dot{m}_h c_h (T_{h1} - T_{h2}) = \dot{m}_c c_c (T_{c2} - T_{c1})$$

$$10(80 - T) = 20(T - 20)$$

$$80 - T = 2(T - 20)$$

$$80 - T = 2T - 40$$

$$120 = 3T$$

$$\Rightarrow T = 40^\circ\text{C}$$

Case – II, For counter flow heat exchanger:

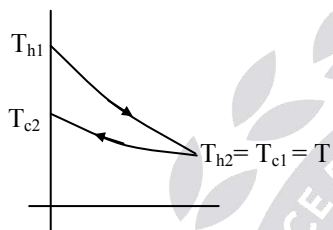

Energy balance:

Heat released by hot fluid = heat received by cold fluid

$$\dot{m}_h c_h (T_{h1} - T_{h2}) = \dot{m}_c c_c (T_{c2} - T_{c1})$$

$$10(80 - T_{c1}) = 20(T_{c2} - T_{c1})$$

$$10(80 - 20) = 20(T_{c2} - 20)$$

$$\Rightarrow T_{c2} = 50^\circ\text{C}$$

08. Ans: (b)

Sol: Given data:

$$Q = 23.07 \times 10^6 \text{ W}, \quad T_{h1} = T_{h2} = 50^\circ\text{C},$$

$$T_{c1} = 15^\circ\text{C}, \quad T_{c2} = 25^\circ\text{C},$$

$$D = 0.0225 \text{ m}, \quad c_c = 4180 \text{ J/kg.K}$$

$$u_{\text{avg}} = 2.5 \text{ m/s}, \quad U = 3160.07 \text{ W/m}^2\text{K},$$

$$\text{LMTD} = 29.72^\circ\text{C}$$

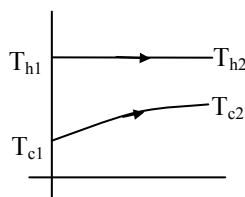

$$\text{Heat transfer rate (Q)} = \dot{m}_c c_c (T_{c2} - T_{c1})$$

$$23.07 \times 10^6 = \dot{m}_c \times 4180(25 - 15)$$

$$\dot{m}_c = 551.91 \text{ kg/sec}$$

$$\dot{m}_{\text{each tube}} = \rho A u_{\text{avg}} = \rho \frac{\pi}{4} D^2 u_{\text{avg}}$$

$$= 998.8 \times \frac{\pi}{4} (0.0225)^2 \times 2.5$$

$$\dot{m}_{\text{each tube}} = 0.7942 \text{ kg/sec}$$

$$\text{No. of tube} \times \dot{m}_{\text{each tube}} = \dot{m}_c$$

$$\text{No. of tube} = \frac{551.91}{0.7942} = 695$$

$$\text{Heat transfer rate (Q)} = U \times A \times \text{LMTD}$$

$$23.07 \times 10^6 = 3160.17 \times A \times 29.72$$

$$\Rightarrow A = 245.64 \text{ m}^2$$

$$A = \pi D L \times \text{No. of tube} \times \text{No. of pass}$$

$$245.64 = \pi \times 0.0225 \times 2.5 \times 695 \times \text{No. of pass}$$

$$\text{No. of pass} = 2$$

09. Ans: (d)

Sol: Effectiveness (ϵ) of heat exchanger will be

$$\text{minimum when } C \left(\frac{C_{\min}}{C_{\max}} \right) = 1$$

Effectiveness of parallel flow heat

$$\text{exchanger} = \frac{1 - e^{-(1+C)NTU}}{1 + C}$$

When $C = 1$

$$\epsilon = \frac{1 - e^{-2NTU}}{2},$$

$$\epsilon = \frac{1 - e^{-2 \times 2.5}}{2} = 0.4966 = 50\%$$