



**ACE**  
Engineering Academy  
(Leading institute for ESE/GATE/PSUs)

# **ESE – 2019 MAINS OFFLINE TEST SERIES**



## **MECHANICAL ENGINEERING**

# **TEST -13 SOLUTIONS**

All Queries related to **ESE – 2019 MAINS Test Series** Solutions are to be sent to the following email address  
[testseries@aceenggacademy.com](mailto:testseries@aceenggacademy.com) | Contact Us : 040 – 48539866 / 040 – 40136222

01(a).

Sol:

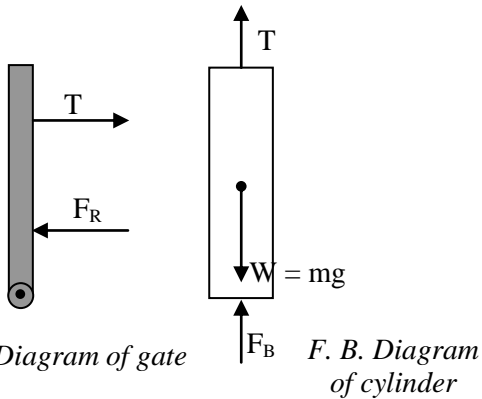

The resultant hydrostatic force on the gate is,

$$F_R = \gamma_w \left( \frac{h}{2} \right) (2 \times h) = \gamma_w h^2$$

The depth of centre of pressure from free liquid surface is,

$$h_{cp} = \frac{2}{3} h$$

Taking moment of the forces about the hinge,

$$T \times 4 = F_R \times \frac{h}{3}$$

where T is the tension in the string

$$T = F_R \times \frac{h}{12} = \gamma_w \times h^2 \times \frac{h}{12} = \frac{\gamma_w h^3}{12}$$

Consider F.B.D of cylinder under equilibrium condition,

$$Mg = T + F_B$$

$$Mg = \frac{\gamma_w h^3}{12} + \gamma_w \times \frac{\pi}{4} \times 1^2 \times (h - 1)$$

$$M = \frac{\rho h^3}{12} + \rho \times \frac{\pi}{4} \times (h - 1)$$

For  $h = 2.5$  m

$$M = 10^3 \left[ \frac{2.5^3}{12} + \frac{\pi}{4} \times 1.5 \right]$$

$$= 10 \times 2.48 = 2480 \text{ kg}$$

01(b).

Sol:

(i). Emissive power,  $(E) = \epsilon \sigma T_s^4$

$$= 0.8(5.67 \times 10^{-8} \text{ W/m}^2 \cdot \text{K}^4)(473 \text{ K})^4$$

$$= 2270 \text{ W/m}^2$$

$$G = \sigma T_{sur}^4 = 5.67 \times 10^{-8} \text{ W/m}^2 \cdot \text{K}^4 (298 \text{ K})^4$$

$$= 447 \text{ W/m}^2$$

(ii). Heat loss from the pipe is by convection to the room air and by radiation exchange with the walls.

Hence,  $q = q_{conv} + q_{rad}$  and from equation with  $A = \pi DL$ .

$$q = h(\pi DL)(T_s - T_\infty) + \epsilon(\pi DL)\sigma(T_s^4 - T_{sur}^4)$$

The heat loss per unit length of pipe is then

$$q' = \frac{q}{L} = 15 \text{ W/m}^2 \cdot \text{K} (\pi \times 0.07 \text{ m}) (200 - 25)^\circ\text{C} + 0.8 (\pi \times 0.07 \text{ m}) 5.67 \times 10^{-8} \text{ W/m}^2 \cdot \text{K}^4 (473^4 - 298^4) \text{K}^4$$

$$q' = 577 \text{ W/m} + 421 \text{ W/m} = 998 \text{ W/m}$$

01(c).

Sol:

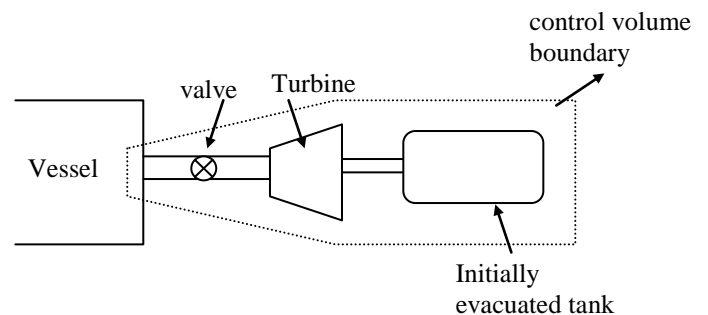

Mass balance for control volume

$$\frac{dm_i}{dt} - \frac{dm_e}{dt} = \left( \frac{dm}{dt} \right)_{c.v.}$$

(where,  $m_i$  = mass entering the control volume,  $m_e$  = mass leaving the control volume)

Energy balance for control volume

$$\frac{d}{dt}[m_i h_i + Q] - \frac{d}{dt}[m_e h_e + w] = \left(\frac{dU}{dt}\right)_{c.v}$$

Since no mass is leaving the control volume

$$\frac{dm_i}{dt} = \left(\frac{dm}{dt}\right)_{c.v}$$

$$\frac{d}{dt}[m_i h_i] - \frac{dw}{dt} = \left(\frac{dU}{dt}\right)_{c.v}$$

$$h_i \frac{dm_i}{dt} - \frac{dw}{dt} = \left(\frac{dU}{dt}\right)_{c.v}$$

Integrating we get

$$h_i(m_2 - m_1) - (m_2 u_2 - m_1 u_1)_{c.v} = W$$

(where  $m_1$  = Initial mass in the c.v

$m_2$  = final mass in the c.v)

$$W = m_2(h_i - u_2)$$

$$m_2 = \frac{V}{v} = \frac{0.6}{0.2027} = 2.96 \text{ kg}$$

$$h_i = 3081.9 \text{ kJ/kg}$$

$$u_2 = 2951.3 \text{ kJ/kg}$$

$$W = 2.96 \times (3081.9 - 2951.3) = 386.6 \text{ kJ}$$

**01(d).**

**Sol:**

- The two stroke SI engines mainly suffer from fuel loss and idling difficulty. The CI engines have no such problems.
- In the two stroke SI engine the air fuel mixture enters into the engine cylinder while both the inlet and exhaust ports remain open. So, some fuel is liable to go out through the exhaust port before the ports are closed. Thus there is a loss of fuel. In the CI engine, only the air enters into the cylinder while the ports

are open and fuel is injected well after the ports are closed. So all the fuel injected takes part in the process of combustion.

- At low engine speed during idling the engine may run irregularly and may even stop. This is because of the dilution of fresh charge with the large amount of residual gases that result due to poor scavenging. At low speeds the burning rate is slow which may cause backfiring in the intake system.
- The problems of the two stroke SI engine can be eliminated if the fuel is injected as soon as the exhaust port closes. It will prevent fuel loss and also backfiring as there is no fuel in the intake system.

**01(e).**

**Sol:**

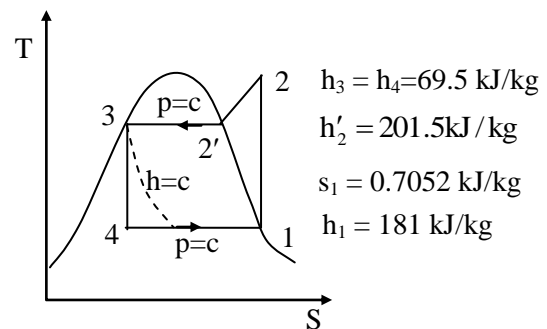

Referring to the table and the figure above.

**1-2**

$$s = c$$

$$s_1 = s_2 = 0.7052 \text{ kJ/kgK}$$

By interpolation for the degree of superheat at discharge.

$$\Delta t = \frac{0.7052 - 0.6839}{0.731 - 0.6839} \times 20 = 9.04^\circ\text{C}$$



Hence,

$$h_2 = 201.5 + \frac{10.2}{20} (216.4 - 201.5)$$

$$= 208.2 \text{ kJ/kg}$$

$$\text{NRE} = 181 - 69.5 = 111.5 \text{ kJ/kg}$$

$$W_{\text{comp}} = 208.2 - 181 = 27.2 \text{ kJ/kg}$$

$$\text{COP} = \frac{\text{NRE}}{W_{\text{comp}}} = \frac{111.5}{27.2} = 4.09$$

$$\frac{\text{HP}}{\text{TR}} = \frac{4.761}{\text{COP}} = \frac{4.761}{4.09} = 1.16$$

**02(a).**

**Sol: Given that,**

Latitude,  $\phi = 40^\circ$

Day of year for August 1,  $n = 213$

Given location ( $\phi = 40^\circ$ )

$$\begin{aligned} \text{Declination, } \delta &= 23.45 \sin \left[ \frac{360}{365} [284 + n] \right] \\ &= 23.45 \sin \left[ \frac{360}{365} [284 + 213] \right] \end{aligned}$$

$$\therefore \delta = 17.913^\circ$$

$$\begin{aligned} \omega_s &= \cos^{-1} [-\tan \phi \tan \delta] \\ &= \cos^{-1} [-\tan(40^\circ) \tan(17.913^\circ)] \end{aligned}$$

$$\therefore \omega_s = 105.737^\circ$$

$$\begin{aligned} \cos \theta_z &= \cos \phi \cos \delta \cos \omega_s + \sin \delta \sin \phi \\ &= \cos 40^\circ \cos 17.913^\circ \cos 105.737^\circ + \sin 17.913^\circ \sin 40^\circ \\ &= -0.2 + 0.2 \end{aligned}$$

$$\cos \theta_z = 0$$

$$\therefore \text{Zenith angle, } \theta_z = 90^\circ$$

(i) Sun's altitude,

$$\sigma = \pi/2 - \theta_z$$

$$\sigma = \pi/2 - \pi/2 = 0$$

$$\therefore \text{Sun's altitude, } \alpha = 0^\circ$$

(ii) Azimuth angle,

$$\begin{aligned} \cos \gamma_s &= \frac{[\cos \theta_z \sin \phi - \sin \delta]}{[\sin \theta_z \sin \phi]} \\ &= \frac{[\cos 90^\circ \sin 40^\circ - \sin 17.913^\circ]}{[\sin 90^\circ \sin 40^\circ]} \end{aligned}$$

$$\cos \gamma_s = -0.478$$

$$\gamma_s = \cos^{-1}(-0.478) = 118.554^\circ$$

$$\therefore \text{Azimuth angle, } \gamma_s = 118.554^\circ$$

**02(b).**

**Sol:**

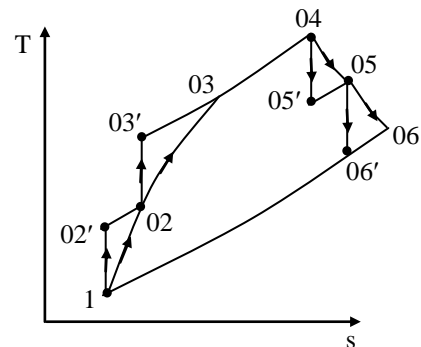

$$(c_{pg} = 1.147 \text{ kJ/kgK, } c_{pa} = 1000 \text{ kJ/kgK})$$

$$P_1 = 0.458 \text{ bar,}$$

$$T_1 = 258 \text{ K, } T_{03} = 1200 \text{ K}$$

$$\begin{aligned} \text{Velocity of air craft} &= V_i = 600 \times \frac{5}{18} \\ &= 166.67 \text{ m/sec} \end{aligned}$$

$$\begin{aligned} \text{Velocity of gases} &= V_g = 600 \times \frac{5}{18} \\ &= 166.67 \text{ m/sec} \end{aligned}$$

$$\begin{aligned} T_{02'} &= T_1 + \frac{V_i^2}{2c_p} = 258 + \frac{166.67^2}{2 \times 1005} \\ &= 271.82 \text{ K} = T_{02} \end{aligned}$$

$$P_{02'} = P_1 \left( \frac{T_{02'}}{T_1} \right)^{\frac{\gamma}{\gamma-1}} = 0.458 \left( \frac{271.82}{258} \right)^{3.5}$$

$$= 0.5497 \text{ bar}$$

Intake duct efficiency = Ram efficiency = 0.9

Ram efficiency

$$= \frac{\text{Actual Rise in pressure}}{\text{Isentropic Rise in pressure}}$$

$$\eta_{\text{ram}} = \frac{P_{02} - P_1}{P_{02'} - P_1}$$

$$P_{02} = P_1 + \eta_{\text{ram}}(P_{02'} - P_1)$$

$$= 0.458 + 0.9(0.5497 - 0.458)$$

$$= 0.5405 \text{ bar}$$

$$\text{Compressor pressure ratio} = \frac{P_{03}}{P_{02}} = 9 = r_p$$

$$P_{03'} = P_{03} = 9P_{02} = 9 \times 0.5405 = 4.865 \text{ bar}$$

$$T_{03'} = T_{02} (r_p)^{\frac{\gamma-1}{\gamma}} = 271.82 \times (9)^{0.286}$$

$$= 509.6 \text{ K}$$

$$\eta_{\text{comp}} = \frac{(\Delta T)_{S=C}}{(\Delta T)_{\text{actual}}} = \frac{T_{03'} - T_{02}}{T_{03} - T_{02}}$$

$$T_{03} = T_{02} + \frac{T_{03'} - T_{02}}{\eta_c}$$

$$\eta_{\text{comp}} = 0.89$$

$$= 271.82 + \frac{509.6 - 271.82}{0.89} = 539 \text{ K}$$

$$\frac{P_{04}}{P_{05}} = \frac{P_{04}}{P_{05'}} = \text{Turbine pressure ratio} = 9$$

$$\gamma_g = 1.147 \text{ kJ/kg.K}$$

$$T_{05'} = T_{04} \left( \frac{P_{04}}{P_{05'}} \right)^{\frac{\gamma_g - 1}{\gamma_g}} = 1200 \left( \frac{1}{9} \right)^{0.248}$$

$$= 695.87 \text{ K}$$

$$\eta_T = 0.9$$

$$\eta_T = \frac{(\Delta T)_{\text{actual}}}{(\Delta T)_{S=C}} = \frac{T_{04} - T_{05}}{T_{04} - T_{05'}}$$

$$T_{05} = T_{04} - \eta_T(T_{04} - T_{05'})$$

$$= 1200 - 0.93(1200 - 695.87)$$

$$= 731.6 \text{ K}$$

$$\text{Transmission efficiency} = \eta_m = 0.98$$

(Because external agent gives work input to compressor)

$$\text{Net work} = \text{Turbine work} - \frac{W_{\text{comp}}}{\eta_m}$$

$$= c_{pg}(T_{04} - T_{05}) - \frac{c_{pa}(T_{05} - T_{02})}{\eta_m}$$

$$= 1.147(1200 - 731.16) - \frac{1.005(539 - 271.82)}{0.98}$$

$$= 263.76 \text{ kJ/kg}$$

$$\eta_{\text{th}} = \frac{W_{\text{net}}}{Q_s} \times 100 = \frac{W_{\text{net}}}{c_{pg}(T_{04} - T_{03})} \times 100$$

$$= \frac{263.76}{1.147(1200 - 539)} \times 100 = 34.79\%$$

**02(c).**

**Sol:**

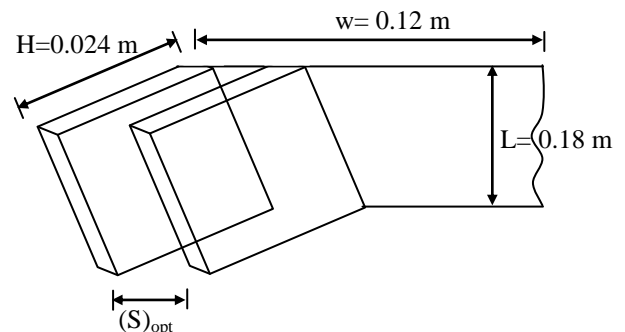

$$T_s = 80^\circ\text{C} = 353 \text{ K}$$

(i) Mean temperature = 325.5 K

$$\frac{T_s + T_\infty}{2} = 325.5$$



$$T_s + T_\infty = 651 \text{ K}$$

$$T_\infty = 651 - 353 = 298 \text{ K} = 25^\circ\text{C}$$

$$\text{Pr} = 0.709$$

Grashoff's number,

$$\begin{aligned} \text{Gr} &= \frac{g \cdot \beta \cdot \Delta T \cdot L^3}{\nu^2} \\ &= \frac{9.81 \times \frac{1}{325.5} (80 - 25) \times 0.18^3}{(1.82 \times 10^{-5})^2} \end{aligned}$$

$$\text{Gr} = 29184714.11$$

$$\text{Ra} = \text{Gr} \cdot \text{Pr} = 20691962.3$$

The optimum fin spacing is to be determined

$$\begin{aligned} (S)_{\text{opt}} &= 2.714 \times \frac{L}{(\text{Ra})^{1/4}} \\ &= 2.714 \times \frac{0.18}{(20691962.3)^{1/4}} \end{aligned}$$

$$(S)_{\text{opt}} = 7.243 \times 10^{-3} \text{ m} = 7.243 \text{ mm}$$

(ii) Number of fins

$$(n) = \frac{W}{(S)_{\text{opt}} + 1} = \frac{120}{7.243 + 1} = 14.55 \approx 15$$

Heat transfer coefficient

$$h = 1.31 \frac{k}{S_{\text{opt}}} = 1.31 \times \frac{0.0279}{0.007243}$$

$$h = 5.046 \text{ W/m}^2$$

Total heat transfer rate,

$$\begin{aligned} Q &= h \cdot A \cdot \Delta T \\ &= 5.046 (2nLH)(T_s - T_\infty) \\ &= 5.046 (2 \times 15 \times 0.18 \times 0.024)(80 - 25) \end{aligned}$$

$$Q = 35.968 \text{ W}$$

**02(d)(i).**

$$\text{Sol: } dq = du + Pdv$$

We know that,  $du = c_v dT$

Also by applying equation of state

$$Pv = RT \Rightarrow P = \frac{RT}{v}$$

Thus we get,

$$dq = c_v dT + \frac{RT}{v} dv$$

Dividing throughout by T

$$\frac{dq}{T} = c_v \frac{dT}{T} + R \frac{dv}{v}$$

$$\text{Now, } \Delta s = \int_1^2 \frac{dq}{T}$$

$$\Delta s = c_v \int_1^2 \frac{dT}{T} + R \int_1^2 \frac{dv}{v}$$

$$\Delta s = c_v \ln\left(\frac{T_2}{T_1}\right) + R \ln\left[\frac{v_2}{v_1}\right]$$

**02(d)(ii).**

**Sol:** Using steady flow energy equation for unit mass

$$h_1 + \frac{V_1^2}{2} + \frac{dQ}{dm} = h_2 + \frac{V_2^2}{2} + \frac{dW}{dm}$$

$$h_1 + \frac{dQ}{dm} = h_2$$

$$\left[ \because \frac{dW}{dm} = 0, V_1 \text{ and } V_2 \text{ are negligible} \right]$$

$$C_p T_1 + \frac{dQ}{dm} = C_p T_2$$

$$\Rightarrow 5.19 \times 50 - 1.75 = 5.19 \times T_2$$

$$\Rightarrow T_2 = 49.7^\circ\text{C}$$



$$S_2 - S_1 = C_p \ln\left(\frac{T_2}{T_1}\right) - R \ln\left(\frac{P_2}{P_1}\right)$$

$$0.25 = 5.19 \ln\left(\frac{49.7 + 273}{50 + 273}\right) - 2.07 \ln\left(\frac{P_2}{300}\right)$$

$$\Rightarrow P_2 = 265 \text{ kPa}$$

**03(a).**

**Sol: Given data:**

$$Q_p = 0.6 \text{ m}^3 / \text{s},$$

$$N_p = 1450 \text{ rpm}, N_m = 1200 \text{ rpm}$$

$$H_p = 20 \text{ m}, \rho_m = 825 \text{ kg/m}^3, \eta_m = \eta_p = 0.8$$

By similarity laws,

$$ND \propto \sqrt{H}$$

$$\therefore \frac{N_m}{N_p} \times \frac{D_m}{D_p} = \sqrt{\frac{H_m}{H_p}}$$

$$\frac{1200}{1450} \times \frac{400}{60} = \sqrt{\frac{H_m}{20}}$$

$$\therefore H_m = 6.08 \text{ m}$$

$$\text{Also, } Q \propto D^2 \sqrt{H} \propto D^2 (ND)$$

$$Q \propto ND^3$$

$$\therefore \frac{Q_m}{Q_p} = \frac{N_m}{N_p} \times \left(\frac{D_m}{D_p}\right)^3$$

$$\frac{Q_m}{0.6} = \frac{1200}{1450} \times \left(\frac{40}{60}\right)^3$$

$$\therefore Q_m = 0.147 \text{ m}^3 / \text{s}$$

$$P_m = \eta_m \rho_m g Q_m H_m$$

$$= 0.8 \times 1000 \times 9.81 \times 0.147 \times 6.08$$

$$= 10.94 \text{ kW}$$

$$N_{sm} = \frac{N_m \sqrt{Q_m}}{H_m^{3/4}} = \frac{1200 \sqrt{0.147}}{6.08^{0.75}} = 118.8$$

$$N_{sp} = \frac{N_p \sqrt{Q_p}}{H_p^{3/4}} = \frac{1450 \sqrt{0.6}}{20^{0.75}} = 118.8$$

**03(b).**

**Sol:** Density of air,

$$\rho_a = \frac{p}{RT} = \frac{1 \times 10^5}{287 \times 300} = 1.161 \text{ kg/m}^3$$

Mass flow rate of air,

$$\dot{m}_a = C_d A_o \sqrt{2g\Delta H \rho_{H_g} \rho_a}$$

Volume flow rate of air,

$$\dot{V}_a = \frac{\dot{m}_a}{\rho_a} = C_d A_a \sqrt{2g\Delta H \rho_{H_g} \rho_a}$$

$$= 0.0761 \text{ m}^3 / \text{s}$$

Swept volume per second,

$$\dot{V}_s = \frac{\pi}{4} d^2 L \frac{N}{2 \times 60} \times n$$

$$= \frac{\pi}{4} (0.1)^2 \times 0.11 \times \frac{2500}{2 \times 60} \times 6$$

$$= 0.108 \text{ m}^3 / \text{s}$$

$$\text{Volumetric efficiency, } \eta_v = \frac{\dot{V}_a}{\dot{V}_s}$$

$$= \frac{0.0761}{0.108} = 0.705 = 70.5\%$$

$$bp = \frac{WN}{20000} = \frac{540 \times 2500}{20000} = 67.5 \text{ kW}$$

$$bmep = \frac{bp}{LA \frac{N}{2 \times 60} n}$$

$$= \frac{67.5 \times 1000 \times 120}{0.11 \times \frac{\pi}{4} (0.1)^2 \times 2500 \times 6}$$

$$= 6.25 \times 10^5 \text{ N/m}^2 = 6.25 \text{ bar}$$

$$bp = \frac{2\pi NT}{60}$$



$$\therefore T = \frac{60 \times bp}{2\pi N} = \frac{60 \times 67.5 \times 1000}{2\pi \times 2500} = 257.8 \text{ N m}$$

Mass rate of fuel,

$$\dot{m}_f = \frac{100}{18} \times 0.78 \times \frac{1}{1000} \times 3600 = 15.6 \text{ kg/h}$$

$$\therefore \text{bsfc} = \frac{\dot{m}_f}{bp} = \frac{15.6}{67.5} = 0.231 \text{ kg/kWh}$$

Stoichiometric oxygen required per kg of

$$\begin{aligned} \text{fuel} &= 0.83 \times \frac{32}{12} + 0.17 \times \frac{8}{1} \\ &= 3.573 \text{ kg/kg fuel} \end{aligned}$$

$\therefore$  Stoichiometric air required

$$= \frac{3573}{0.23} = 15.54 \text{ kg/kg fuel}$$

Actual mass flow rate of air =  $\dot{V}_a \times \rho_a$

$$= 0.0761 \times 1.161 = 0.0884 \text{ kg/s}$$

$$\text{Actual air/fuel ratio} = \frac{0.0884 \times 3600}{15.6} = 20.4$$

**03(c).**

**Sol: Given data:**

Difference between the tides (H) = 9 m

Basin area (A) =  $0.45 \times 10^6 \text{ m}^2$

Total time (t) = 3 hours =  $3 \times 3600 \text{ sec}$

Average available head (H') = 8.5 m

Overall efficiency ( $\eta_{\text{overall}}$ ) = 72% = 0.72

Density of sea water ( $\rho$ ) =  $1025 \text{ kg/m}^3$

Volume of basin = AH

$$= 0.45 \times 10^6 \times 9$$

$$= 4.05 \times 10^6 \text{ m}^3$$

Average discharge,  $Q = \frac{v}{t}$

$$= \frac{AH}{t} \quad [ \because v = AH ]$$

$$= \frac{4.05 \times 10^6}{3 \times 3600}$$

$$= \frac{4.05 \times 10^6}{3 \times 3600}$$

$$Q = 375 \text{ m}^3 / \text{sec}$$

**(i) Power at any instant,**

$$P = \rho g Q H' \times \eta_{\text{overall}}$$

$$= 1025 \times 9.81 \times 375 \times 8.5 \times 0.72$$

$$P = 23077 \text{ kW}$$

**(ii) Yearly power output,**

Energy generated per tidal cycle,

$$E_t = P \times t$$

$$= 23077 \times 3$$

$$E_t = 69231 \text{ kWh}$$

Total number of tidal cycle in a year = 705

$\therefore$  Year power output,

$$P_{\text{year}} = E_t \times 705$$

$$= 69231 \times 705$$

$$P_{\text{year}} = 488.08 \times 10^5 \text{ kWh / year}$$

**03(d).**

**Sol:** From the Pitot - static tube and manometer,

(i)  $P_o - P = (\rho_{\text{oil}} - \rho_{\text{air}})g\Delta h$

$$= (827 - 1.2) \times 9.81 \times 0.046$$

$$= 372.65 \text{ N/m}^2$$

Centreline velocity

$$V_{\text{centreline}} = \sqrt{\frac{2(P_o - P)}{\rho_{\text{air}}}} = \sqrt{\frac{2 \times 372.65}{1.2}}$$

$$= 24.92 \text{ m/s}$$





(ii)  $V_{av} = 0.85 \times 24.92 = 21.182 \text{ m/s}$

Therefore, volume flow rate of air

$$= \frac{\pi}{4} \times 0.1^2 \times 21.182 = 0.166 \text{ m}^3/\text{s}$$

(iii) Since the flow is turbulent

$$V_{av} = \frac{V_{\text{centreline}}}{(1 + 1.33\sqrt{f})}$$

$$\text{Or, } 1 + 1.33\sqrt{f} = \frac{V_{\text{centreline}}}{V_{av}} = \frac{1}{0.85} = 1.176$$

$$1.33\sqrt{f} = 0.176$$

$$\sqrt{f} = 0.1323$$

$$f = 0.0175$$

Hence, wall shear stress,

$$\begin{aligned} \tau &= \frac{f\rho V_{av}^2}{8} \\ &= \frac{0.0175 \times 1.2 \times 21.182^2}{8} \\ &= 1.178 \text{ N/m}^2 \end{aligned}$$

**04(a).**

**Sol:**  $\text{AFR} = \frac{\dot{m}_a}{\dot{m}_f} = 16 \text{ kg/kgfuel}$

$$\dot{m}_f = 16 \text{ kg/hr}$$

$h = 20 \text{ mm of H}_2\text{O column}$

$$T_a = 27^\circ\text{C} + 273 = 300 \text{ K}$$

$$T_g = 277 + 273 = 550 \text{ K}$$

$$v_{act} = 0.35 v_g$$

Draught in mm of water is given by

$$h = 353 H \left[ \frac{1}{T_a} - \left( \frac{m_a + 1}{m_a} \right) \frac{1}{T_g} \right]$$

$$20 = 353 H \left[ \frac{1}{300} - \left( \frac{16 + 1}{16} \right) \frac{1}{550} \right]$$

$$\Rightarrow H = 40.43 \text{ m}$$

Density of flue gases

$$\begin{aligned} \rho_g &= \frac{353}{T_g} \left( \frac{m_a + 1}{m_a} \right) \\ &= \frac{353}{550} \left( \frac{16 + 1}{16} \right) = 0.683 \text{ kg/m}^3 \end{aligned}$$

Mass flow rate of flue gases

$$\begin{aligned} \dot{m}_g &= (m_a + 1) \frac{\dot{m}_f}{3600} \\ &= (16 + 1) \left( \frac{1800}{3600} \right) = 8.5 \text{ kg/sec} \end{aligned}$$

Draught equivalent of hot gas column

$$\begin{aligned} H' &= H \left[ \left( \frac{m_a}{m_a + 1} \right) \frac{T_g}{T_a} - 1 \right] \\ H' &= 40.43 \left[ \left( \frac{16}{16 + 1} \right) \frac{550}{300} - 1 \right] = 29.33 \text{ metres} \end{aligned}$$

Actual velocity of flue gases

$$\begin{aligned} V_{act} &= k\sqrt{2gH'} \\ &= 0.35\sqrt{2 \times 9.8 \times 29.33} \\ &= 8.396 \text{ m/sec} \end{aligned}$$

Mass flow rate of flue gases

$$\begin{aligned} \dot{m}_g &= \rho_g A V_{act} \\ 8.5 &= 0.682 \times \frac{\pi}{4} D^2 \times 8.396 \end{aligned}$$

Diameter of chimney,  $D = 1.375 \text{ m}$

**04(b).**

**Sol: Given Data:**

$$W = 1000 \text{ N,}$$

$$V_1 = 40 \text{ m/s}$$

$$C_D = 1.3, \quad \rho = 1.2 \text{ kg/m}^3$$

$$V_2 = 4 \text{ m/s}$$

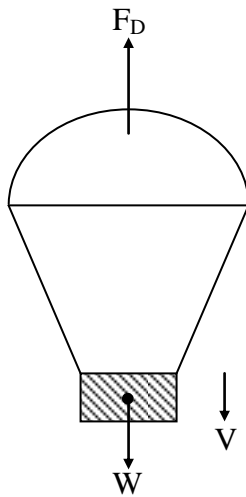

By Newton's second law of motion,

$$\Sigma \vec{F} = m\vec{a}$$

$$\text{i.e } W - F_D = m \frac{dV}{dt} \rightarrow (1)$$

When parachute comes down with steady sinking speed acceleration is zero

$$\therefore W - F_D = 0$$

$$1000 = \frac{C_D}{2} \times \rho A V^2$$

$$A = \frac{2 \times 1000}{1.2 \times 1.3 \times 4^2} = 80.13 \text{ m}^2$$

From equation (1)

$$W - \frac{C_D}{2} \rho A V^2 = m \frac{dV}{dt}$$

$$\therefore dt = \frac{m dV}{W - \frac{C_D}{2} \rho A V^2}$$

$$dt = \frac{\frac{2m}{C_D \rho A} dV}{\frac{2W}{C_D \rho A} - V^2}$$

$$dt = \frac{bdV}{a^2 - V^2} \rightarrow (3)$$

where,

$$b = \frac{2m}{C_D \rho A} = \frac{2 \times 100}{1.3 \times 1.2 \times 80.13} = 1.6$$

$$a = \sqrt{\frac{2W}{C_D \rho A}} = \sqrt{\frac{2 \times 1000}{1.3 \times 1.2 \times 80.13}} = 4$$

Integrating on both sides

$$\int dt = \int \frac{bdV}{a^2 - V^2} + C$$

$$t = \frac{b}{2a} \ln \left| \frac{a+V}{a-V} \right| + C$$

At  $t = 0$ ,  $V = 40 \text{ m/s}$

$$\therefore C = \frac{-1.6}{2 \times 4} \times \ln \left| \frac{4+40}{4-40} \right| = 0.04$$

$$\therefore t = \frac{b}{2a} \ln \left| \frac{1+V/a}{1-V/a} \right| - 0.04$$

**Note:**  $a = \sqrt{\frac{2W}{C_D \rho A}} = 4 \text{ m/s} = \text{Equilibrium}$

sinking speed at 99.9% equilibrium speed  
 $V/a = 0.999$

$$\therefore t = \frac{1.6}{2 \times 4} \ln \left| \frac{1.999}{0.001} \right| - 0.04 = 1.48 \text{ sec}$$

From equation (1)

$$W - F_D = m \frac{dV}{dy} \frac{dy}{dt}$$

$$W - \frac{C_D}{2} \rho A V^2 = mV \frac{dV}{dy}$$

$$\therefore dy = \frac{m}{W - \frac{C_D}{2} \rho A V^2} \cdot V dV \rightarrow (4)$$

Comparing equation (2) (3) and (4)

$$dy = \frac{bV dV}{a^2 - V^2}$$

$$\therefore y = b \int \frac{V dV}{a^2 - V^2} + c$$



$$= \frac{-b}{2} \int \frac{(-2v)dv}{a^2 - v^2} + c$$

$$y = \frac{-b}{2} \ln|4^2 - v^2| + c$$

At  $y = 0$ ,  $v = 40$  m/s

$$\Rightarrow c = \frac{1.6}{2} \ln a^2 \left( 1 - \left( \frac{v}{a} \right)^2 \right) + 5.89$$

$$= \frac{-1.6}{2} \ln|16(1 - 0.999^2)| + 5.89$$

$$= 8.648 \text{ m}$$

**04(c).**

**Sol: Assumption :**

The streamlines are parallel at locations (1), (2) and (3).

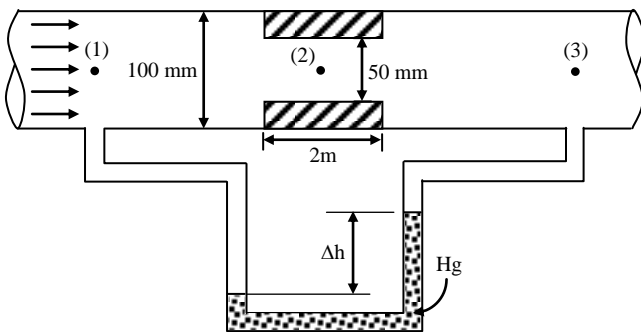

$$Re_1 = \frac{V_1 D}{\nu} = \frac{4Q}{\pi \nu D} = \frac{4 \times 0.015}{\pi \times 10^{-6} \times 0.1} = 1.91 \times 10^5 = Re_3$$

$\Rightarrow$  Flow is turbulent

$$Re_2 = 2 \times Re_1 \quad (\text{as } d = D/2) = 3.82 \times 10^5$$

$$\text{Thus, } f_1 = f_3 = \frac{0.316}{(1.91 \times 10^5)^{1/4}} = 0.015$$

and  $f_2 = 0.0127$

Applying energy equation for points (1) & (3)

$$\frac{P_1}{\gamma_w} + \frac{V_1^2}{2g} + Z_1 = \frac{P_3}{\gamma_w} + \frac{V_3^2}{2g} + Z_3 + 2h_{f1} + h_{f2} + h_{L \text{ contraction}} + h_{L \text{ expansion}}$$

Here,  $V_1 = V_3$  and  $Z_1 = Z_3$

$$h_{L \text{ contraction}} = K_{\text{contraction}} \times \frac{V_2^2}{2g}$$

$$\frac{P_1 - P_3}{\gamma_w} = \frac{2 \times f_1 L_1 Q^2}{12.1 D^5} + \frac{f_2 L_2 Q^2}{12.1 d^5} + K_{\text{contraction}} \times \frac{Q^2}{12.1 d^4} + \frac{V_2^2}{2g} \left( 1 - \frac{V_3}{V_2} \right)^2$$

$$\frac{P_1 - P_3}{\gamma_w} = \frac{2f_1 L_1 Q^2}{12.1 D^5} + \frac{f_2 L_2 Q^2}{12.1 d^5} + K_{\text{contraction}} \times \frac{Q^2}{12.1 d^4} + \frac{Q^2}{12.1 d^4} \left( 1 - \left( \frac{50}{100} \right)^2 \right)^2$$

$$= \frac{Q^2}{12.1} \left[ \frac{2f_1 L_1}{D^5} + \frac{K_{\text{contraction}}}{d^4} + \frac{f_2 L_2}{d^5} + \frac{1}{d^4} \times \frac{9}{16} \right]$$

$$= \frac{Q^2}{12.1} \left[ \frac{2 \times 0.015 \times 4}{0.1^5} + \frac{0.48}{0.05^4} + \frac{0.0127 \times 2}{0.05^5} + \frac{1}{0.05^4} \times \frac{9}{16} \right]$$

$$= \frac{0.015^2}{12.1} [12000 + 76800 + 81,280 + 90,000]$$

$$= \frac{0.015^2 \times 260080}{12.1}$$

$$= 3.259 \text{ m}$$

From the manometer,

$$\frac{P_1 - P_3}{\gamma_w} = \Delta h \left( \frac{\gamma_{\text{Hg}}}{\gamma_w} - 1 \right) = \Delta h (13.6 - 1) = 12.6 \Delta h$$

$$\text{Thus, } \Delta h = \frac{3.259}{12.6} = 0.258 \text{ m} = 258 \text{ mm}$$

(ii) When major losses, i.e., frictional losses are neglected, then

$$\frac{P_1 - P_3}{\gamma_w} = \frac{0.015^2}{12.1} [76800 + 90000] = 3.1016 \text{ m}$$

$$\text{Thus, } \Delta h = \frac{3.1016}{12.6} = 0.246 \text{ m} = 246 \text{ mm}$$

Thus, there is a percentage reduction in  $\Delta h$  given by

$$\% \text{ reduction in } \Delta h = \left( 1 - \frac{246}{258} \right) \times 100 = 4.65 \%$$

05(a).

Sol: Given:  $\Delta h = 740 \text{ mm} = 0.74 \text{ m}$   
 $d_s = 100 \text{ mm} = 0.1 \text{ m};$   
 $d_d = 80 \text{ mm} = 0.08 \text{ m}$

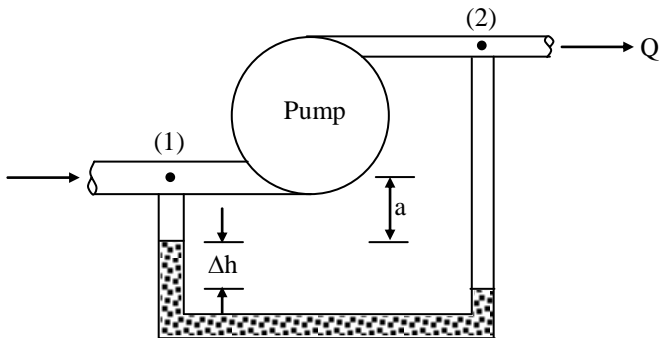

The velocity of water in suction pipe,

$$V_s = \frac{4Q}{\pi d_s^2} = \frac{4 \times 3.42 / 60}{\pi \times 0.1^2} = 7.257 \text{ m/s}$$

$$\text{Similarly, } V_d = \frac{4Q}{\pi d_d^2} = 4 \times \frac{3.42}{60} \times \frac{1}{\pi \times 0.08^2}$$

$$= 11.34 \text{ m/s}$$

Applying energy equation for points (1) & (2)

we get,

$$\frac{P_1}{\gamma_w} + \frac{V_s^2}{2g} + Z_1 + h_{\text{pump}} = \frac{P_2}{\gamma_w} + \frac{V_d^2}{2g} + Z_2$$

$$h_{\text{pump}} = \frac{P_2 - P_1}{\gamma_w} + \frac{V_d^2 - V_s^2}{2g} + (Z_2 - Z_1) \text{ -----(1)}$$

From manometric equation:

$$P_1 + \gamma_w a + \gamma_{\text{Hg}} \Delta h = P_2 + \gamma_w (Z_2 - Z_1 + a + \Delta h)$$

$$P_2 - P_1 = (\gamma_{\text{Hg}} - \gamma_w) \Delta h - \gamma_w (Z_2 - Z_1)$$

$$= \gamma_w \left( \frac{\gamma_{\text{Hg}}}{\gamma_w} - 1 \right) \Delta h - \gamma_w (Z_2 - Z_1)$$

$$\frac{P_2 - P_1}{\gamma_w} = \left( \frac{\gamma_{\text{Hg}}}{\gamma_w} - 1 \right) \Delta h - (Z_2 - Z_1)$$

$$= (13.6 - 1)0.74 - 0.33 = 8.994 \text{ m}$$

Substituting the value of  $\frac{P_2 - P_1}{\gamma_w}$  into

equation (1), we get

$$h_{\text{pump}} = 8.994 + \frac{11.34^2 - 7.257^2}{2 \times 9.81} + 0.33$$

$$= 8.994 + 3.87 + 0.33 = 13.194 \text{ m}$$

05(b).

Sol:

- (i) Dry matter produced by two cows  
 $= 2 \times 2 = 4 \text{ kg/day}$

As dry matter content in cow dung is only 18%, cow dung produced

$$= 4/0.18 = 22.22 \text{ kg/day}$$

Equal quantity of water is added to make the slurry. The amount of slurry produced per day = 22.22 + 22.22 = 44.44 kg/day

Slurry volume produced per day

$$= \frac{44.44}{1090} = 0.04077 \text{ m}^3/\text{day}$$

With retention time of 30 days, total slurry volume in the digester

$$= 30 \times 0.04077 = 1.223 \text{ m}^3$$

As about 15% digester area is occupied by the gas, the net

$$\text{Digester size} = 1.223/0.85 = 1.44 \text{ m}^3$$

$$\text{Gas produced} = 4 \times 0.22 = 0.88 \text{ m}^3/\text{day}$$

Thermal energy available

$$= 0.88 \times 23 \times 0.6 = 12.144 \text{ MJ/day}$$

Continuous thermal power available

$$= \frac{12.144 \times 10^6}{24 \times 60 \times 60} = 140.55 \text{ W}$$

**05(c).**
**Sol: Given data:**

$$P = 50 \text{ MW}, \quad H = 15 \text{ m}, \quad N = 150 \text{ rpm}$$

$$N_{s1} = 300, \quad N_{s2} = 600,$$

$$\sigma_{c1} = 0.35, \quad \sigma_{c2} = 0.5$$

$$N_{s1} = \frac{N\sqrt{P_1}}{H^{5/4}}$$

$$\text{i.e. } 300 = \frac{150\sqrt{P_1}}{15^{1.25}}$$

$$\Rightarrow P_1 = 3487 \text{ kW} = 3.487 \text{ MW}$$

 No. of unit of Francis turbine ( $n_1$ ) are

$$n_1 = \frac{50}{3.487} = 14.34 \approx 15 \text{ units}$$

$$\sigma_c = \frac{H_a - H_{s,\max} - H_v}{H}$$

For Francis turbine,

$$0.35 = \frac{10.3 - H_{s,\max} - 0.3}{15}$$

$$H_{s,\max} = 4.75 \text{ m}$$

$$N_{s2} = \frac{N\sqrt{P_2}}{H^{5/4}}$$

$$\text{i.e. } 600 = \frac{150\sqrt{P_2}}{15^{5/4}}$$

$$\therefore P_2 = 13943 \text{ kW} = 13.943 \text{ MW}$$

Number of units for Kaplan turbine are,

$$n_2 = \frac{50}{13.94} = 3.586 \approx 4 \text{ units}$$

Critical cavitation factor for Kaplan turbine

 is given by,  $\sigma_{c1} = 0.5$ 

$$\frac{H_a - H_{s,\max} - H_v}{H} = 0.5$$

$$\therefore H_{s,\max} = H_a - H_v - 0.5 \times H$$

$$= 10.3 - 0.3 - 0.5 \times 15 = 2.5 \text{ m}$$

Hence, draft tube height for Kaplan turbine should be less than 2.5 m and that for Francis turbine should be less than 4.75 m.

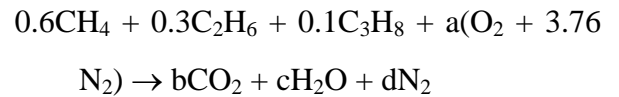
**05(d).**
**Sol:** The combustion equation is written as

Carbon balance :

$$0.6 + 0.6 + 0.3 = b$$

$$\Rightarrow b = 1.5$$

Hydrogen balance:

$$2.4 + 1.8 + 0.8 = 2c$$

$$\Rightarrow c = 2.5$$

 O<sub>2</sub> Balance:

$$2a = 2b + c = 2 \times 1.5 + 2.5$$

$$a = 2.75$$

 N<sub>2</sub> Balance:

$$2 \times 3.76a = 2d$$

$$\Rightarrow d = 3.76a = 3.76 \times 2.75 = 10.34$$

Air Fuel ratio,

$$\frac{\dot{m}_a}{\dot{m}_f} = \frac{2.75 \times 4.76 \times 28.97}{0.6 \times 16 + 0.3 \times 30 + (0.1)(44)} = 16.49$$

$$\frac{\dot{m}_a}{\dot{m}_f} = \text{AFR}$$

$$\dot{m}_a = (\text{AFR})\dot{m}_f = 16.49 \times 12 = 197.88 \text{ kg/hr}$$

$$P = 101.325 \text{ kPa}, \quad T = 298 \text{ K}$$

Volume flow rate of air

$$\begin{aligned} \dot{V}_a &= \frac{\dot{m}_a RT}{P} \\ &= \frac{197.88 \times 0.287 \times 298}{101.325} \\ &= 167.025 \text{ m}^3/\text{hr} \end{aligned}$$

Partial pressure of water vapor in products

$$= \frac{\text{No. of moles of H}_2\text{O vap}}{\text{Total No. of moles}} \times P_{\text{atm}}$$

$$= \frac{2.5}{1.5 + 2.5 + 10.34} \times 101.325$$

$$= 17.664 \text{ kPa}$$

Corresponding to 17.664 kPa pressure whatever is the saturation temperature will be the dew point temperature.

From the table given, DPT is 57.6°C (by interpolation).

05(e).

Sol: Given data:

$$P_1 = 200 \text{ kPa}, \quad T_1 = 300 \text{ K},$$

$$V_1 = 0.5 \text{ m}^3,$$

$$m = \frac{P_1 V_1}{RT_1} = \frac{200 \times 0.5}{0.287 \times 300} = 1.16 \text{ kg}$$

If the piston just touches the stopper the pressure of air becomes,  $P_2 = 400 \text{ kPa}$  and volume becomes,  $V_2 = 1 \text{ m}^3$

Now,

$$\frac{P_1 V_1}{T_1} = \frac{P_2 V_2}{T_2}$$

$$\Rightarrow \frac{200 \times 0.5}{300} = \frac{400 \times 1}{T_2}$$

$$\Rightarrow T_2 = 1200 \text{ K}$$

This process is represented on P-V diagram as shown below.

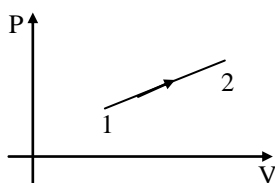

Again as air is heated to 1500 K so pressure will rise further. Let this pressure becomes  $P_3$ .

Now,

$$\frac{P_2 V_2}{T_2} = \frac{P_3 V_3}{T_3}$$

$$\frac{200 \times 0.5}{300} = \frac{P_3 \times 1}{1500} \Rightarrow P_3 = 500 \text{ kPa}$$

This process is represented on P-V diagram as shown below

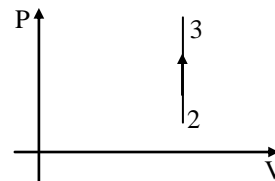

Complete process is represented on P-V diagram as shown below

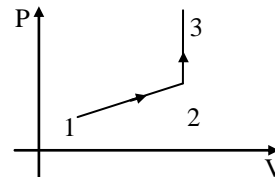

Applying first law of thermodynamics for process 1-2-3

$$Q - W = \Delta U \dots\dots\dots (i)$$

$$W = \frac{1}{2} \times [P_1 + P_2] \times \Delta V$$

$$= \frac{1}{2} \times [200 + 400] \times 0.5 = 150 \text{ kJ}$$

Putting in (i)

$$Q - 150 = 1.16 \times C_v \times (1500 - 300)$$

$$Q = 1148 \text{ kJ}$$

06(a).

**Sol:** For the heat engine, the heat rejected  $Q_2$  to the panel (at  $T_2$ ) is equal to the energy emitted from the panel to the surroundings by radiation.

If  $A$  is the area of the panel,  $Q_2 \propto AT_2^4$  or  $Q_2 = KAT_2^4$ , where  $K$  is a constant.

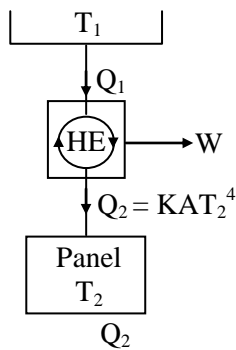

$$\text{Now, } \eta = \frac{W}{Q_1} = \frac{T_1 - T_2}{T_1}$$

$$\frac{W}{T_1 - T_2} = \frac{Q_1}{T_1} = \frac{Q_2}{T_2} = \frac{KAT_2^4}{T_2} = KAT_2^3$$

$$\therefore A = \frac{W}{KT_2^3(T_1 - T_2)} = \frac{W}{K(T_1T_2^3 - T_2^4)}$$

For a given  $W$  and  $T_1$ ,  $A$  will be minimum when

$$\frac{dA}{dT_2} = -\frac{W}{K} (3T_1T_2^2 - 4T_2^3) (T_1T_2^3 - T_2^4)^{-2} = 0$$

$$\text{Since } (T_1T_2^3 - T_2^4)^{-2} \neq 0, \quad 3T_1T_2^2 = 4T_2^3$$

$$\therefore \frac{T_2}{T_1} = 0.75 \text{ Proved.}$$

$$\begin{aligned} \therefore A_{\min} &= \frac{W}{K(0.75)^3 T_1^3 (T_1 - 0.75T_1)} \\ &= \frac{W}{K \left(\frac{27}{256}\right) T_1^4} = \frac{256W}{27KT_1^4} \end{aligned}$$

Here,  $W = 1 \text{ kW}$ ,

$$K = 5.67 \times 10^{-8} \text{ W/m}^2\text{K}^4, \text{ and}$$

$$T_1 = 1000 \text{ K}$$

$$\begin{aligned} \therefore A_{\min} &= \frac{256 \times 1 \text{ kW} \times \text{m}^2\text{K}^4}{27 \times 5.67 \times 10^{-8} \times 10^{12} \text{ m}^2} \\ &= 0.1672 \text{ m}^2 \end{aligned}$$

06(b).

**Sol:**

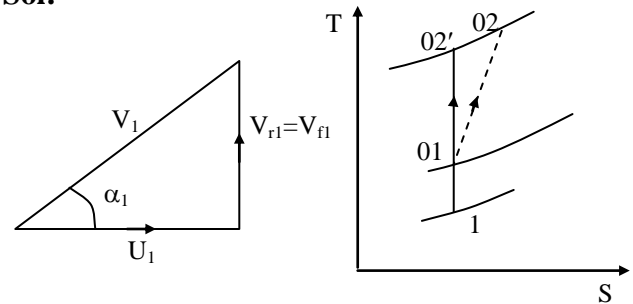

Speed = 10,000 rpm

Volume flow rate of air =  $\dot{V} = 600 \text{ m}^3 / \text{min}$

$$\eta_{\text{comp}} = 0.82$$

$$T_{01} = 293 \text{ K}$$

$$P_{01} = 100 \text{ kPa}$$

$$\text{Pressure ratio of compressor} = r_p = \frac{P_{02}}{P_{01}} = 4$$

$$T_{02'} = T_{01} (r_p)^{\frac{\gamma-1}{\gamma}} = 293(4)^{\frac{1.4-1}{1.4}} = 435.56 \text{ K}$$

$$\eta_c = \frac{W_{s=c}}{W_{\text{act}}} = \frac{T_{02'} - T_{01}}{T_{02} - T_{01}}$$

$$\begin{aligned} T_{02} &= T_{01} + \frac{T_{02'} - T_{01}}{\eta_c} = 293 + \frac{435.56 - 293}{0.82} \\ &= 466.85 \text{ K} \end{aligned}$$

$$\begin{aligned} \text{Euler's work} &= U_2^2 = c_p (dT) \\ &= 1005(466.85 - 293) \\ &= 174719.25 \text{ m}^2/\text{s}^2 \\ &= 174.71925 \text{ kW/kg/sec} \end{aligned}$$

Blade velocity at  $U_2 = 418 \text{ m/s}$

$$U_2 = \frac{\pi D_2 N}{60}$$



$$\begin{aligned} \text{Tip Diameter} = D_2 &= \frac{60U_2}{\pi N} \\ &= \frac{60 \times 418}{\pi \times 10,000} = 0.8 \text{ m} \end{aligned}$$

$$\text{Inner diameter} = \frac{\text{Outer Diameter}}{2}$$

$$\text{Inlet diameter} = D_1 = \frac{D_2}{2} = \frac{0.8}{2} = 0.4 \text{ m}$$

$$T_{01} = T_1 + \frac{V_{f1}^2}{2c_p}$$

$$T_1 = T_{01} - \frac{V_{f1}^2}{2c_p} = 293 - \frac{60^2}{2 \times 1005} = 291.2 \text{ K}$$

$$\frac{T_{01}}{T_1} = \left( \frac{P_{01}}{P_1} \right)^{\frac{\gamma-1}{\gamma}} ;$$

$$P_1 = P_{01} \left( \frac{T_1}{T_{01}} \right)^{\frac{\gamma}{\gamma-1}} = 1 \left( \frac{291.2}{293} \right)^{3.5} = 0.9785 \text{ bar}$$

$$\left[ \frac{\gamma}{\gamma-1} = \left( \frac{1.4}{1.4-1} \right) = 3.5 ; \frac{\gamma-1}{\gamma} = \frac{1.4-1}{1.4} = 0.286 \right]$$

$\rho_1$  = Density of air at inlet to eye

$$= \frac{P_1}{RT_1} = \frac{0.9787 \times 10^2}{0.287 \times 2912} = 1.171 \text{ kg/m}^3$$

$$\text{Discharge} = \dot{Q} = AV_{f1} = \pi D_1 W_{\text{root}} \times V_{f1}$$

$$\text{Width of root} = W_{\text{root}} = \frac{\dot{Q}}{\pi D_1 V_{f1}}$$

$$= \frac{600}{\pi \times 0.4 \times 60} = 0.133 \text{ m}$$

$$U_1 = \frac{\pi D_1 N}{60} = \frac{\pi \times 0.4 \times 10000}{60}$$

$$U_1 = 209.4 \text{ m/sec}$$

$$\text{Inlet blade velocity} = U_1 = 209.4 \text{ m/sec}$$

$$\tan \alpha_1 = \frac{V_{f1}}{U_1} = \frac{60}{209.4} = 16^\circ$$

$$\tan \alpha_2 = \frac{V_{f2}}{U_2} = \frac{60}{418} \quad (V_{f1} = V_{f2})$$

$$\text{Diffuser blade angle at inlet} = \alpha_2 = \tan^{-1} \frac{V_{f2}}{U_2}$$

$$= \tan^{-1} \frac{60}{418} = 8.17^\circ$$

**06(c).**

**Sol: Given data:**

$$\text{DBT} = 5^\circ\text{C}, \quad \text{WBT} = 2.5^\circ\text{C},$$

$$Q = 90 \text{ m}^3/\text{min},$$

$$\dot{Q}_s = 40.7 \text{ kW},$$

$$\dot{m}_s = 40 \text{ kg/hr}, \quad h_s = 2691.3 \text{ kJ/kg}$$

Initial state of air (state 1) can be obtained from psychrometric chart knowing DBT and WBT

$$T_1 = 5^\circ\text{C}, \quad \omega_1 = 0.0035 \text{ kg/kg},$$

$$h_1 = 14 \text{ kJ/kg}, \quad v_1 = 0.792 \text{ m}^3/\text{kg}$$

$h_1$  can also be calculated as,

$$\begin{aligned} h_1 &= c_{p_a} T_1 + \omega (c_{p_v} T_1 + h_{fg}) \\ &= 1.005 \times 5 + 0.0035 (1.88 \times 5 + 2500) \\ &= 13.8 \text{ kJ/kg} \end{aligned}$$

$$\dot{m}_a = \frac{Q}{v_1} = \frac{90/60}{0.792} = 1.894 \text{ kg/s}$$

When 40.7 kW of sensible heat is added to the air its enthalpy increases but specific humidity remains same. The state 2 can be determined by knowing enthalpy and specific humidity.

$$\therefore \omega_2 = \omega_1 = 0.0035 \text{ kg/kg}$$



$$\dot{Q}_s = \dot{m}_a (h_2 - h_1)$$

$$\therefore h_2 = h_1 + \frac{\dot{Q}_s}{\dot{m}_a} = 13.8 + \frac{40.7}{1.894} = 35.3 \text{ kJ/kg}$$

Specific humidity of final state (state 3) can be obtained by adding vapour added per unit mass of dry air into specific humidity of state 2.

$$\begin{aligned} \therefore \omega_3 &= \omega_2 + \frac{\dot{m}_s}{\dot{m}_a} = 0.0035 + \frac{40/3600}{1.894} \\ &= 0.0094 \text{ kg/kg} \end{aligned}$$

By energy balance :

$$\dot{m}_a (h_3 - h_2) = \dot{m}_s h_s$$

$$\begin{aligned} h_3 &= h_2 + \frac{\dot{m}_s}{\dot{m}_a} \times h_s \\ &= 35.3 + \frac{40/3600}{1.894} \times 2691.3 = 51.1 \text{ kJ/kg} \end{aligned}$$

By knowing  $h_3$  and  $\omega_3$ , DBT and WBT can be obtained using psychrometric chart

$$T_3 = 27^\circ \text{C}, T_{w_3} = 18^\circ \text{C}$$

**06(d).**

**Sol:**

(a) Cylinder,

$$Re_d = \frac{U_\infty D}{\nu} = \frac{32 \times 0.025}{16.84 \times 10^{-6}} = 47506$$

$$\begin{aligned} Nu_m &= [0.4(47506)^{0.5} + 0.06(47506)^{2/3}] (0.708)^{0.4} \\ &= (87.18 + 78.98) \times 0.87 = 144.56 \end{aligned}$$

$$h = \frac{144.56 \times 0.0262}{0.025} = 151.5 \text{ W/m}^2 \text{K}$$

$$\begin{aligned} Q &= h \pi DL (T_w - T_\infty) \\ &= 151.5 \times \pi \times 0.0251 \times 0.5 (350 - 250) \\ &= 595 \text{ W} \end{aligned}$$

(b) Sphere,

$$Re_d = \frac{U_\infty D}{\nu} = \frac{32 \times 0.025}{16.84 \times 10^{-6}} = 47506$$

$$Nu = 2 + 144.56 = 146.56$$

$$h = \frac{146.56 \times 0.0262}{0.025} = 153.6 \text{ W/m}^2 \text{K}$$

$$\begin{aligned} Q &= h \pi D^2 (T_w - T_\infty) \\ &= 153.6 \times \pi \times (0.025)^2 (350 - 250) \\ &= 30.15 \text{ W} \end{aligned}$$

$$\frac{Q_{\text{cylinder}}}{Q_{\text{sphere}}} = \frac{595}{30.15} = 19.73$$

**07(a).**

**Sol:** Given data :

$$L_p = 2000 \text{ m}, D_p = 0.5 \text{ m}, f = 0.017,$$

$$H_g = 500 \text{ m}, m = 15, k_u = 0.40,$$

$$d = 8 \text{ cm}, k = 0.9$$

$$\beta_2 = 180^\circ - 165^\circ = 15^\circ,$$

$$\eta_m = 0.92, C_v = 0.98$$

(i)  $H_g = H + h_f$

$$H_g = \frac{V^2}{2gC_v^2} + \frac{fL_p V_p^2}{2gD_p} \quad \left\{ \because V = C_v \sqrt{2gH} \right\}$$

where V is the jet velocity leaving the nozzle.

$$\text{i.e } 500 = \frac{V^2}{2g} \left[ \frac{1}{C_v^2} + \frac{fL_p}{D_p} \times \left( \frac{V_p}{V} \right)^2 \right]$$

$$500 = \frac{V^2}{2g} \left[ \frac{1}{C_v^2} + \frac{fL_p d^4}{D^5} \right]$$

$$500 = \frac{V^2}{2 \times 9.81} \left[ \frac{1}{0.98^2} + \frac{0.017 \times 2000 \times 0.08^4}{0.5^4} \right]$$

$$V = 95.05 \text{ m/s}$$



$$H = \frac{V^2}{2gC_v^2} = \frac{95.05^2}{2 \times 9.81 \times 0.98^2} = 479.5 \text{ m}$$

$$h_f = H_g - H = 500 - 479.5 = 20.5 \text{ m}$$

$$(ii) \quad m = \frac{D}{d} = 15$$

$$\therefore D = 15 \times 0.08 = 1.2 \text{ m}$$

$$u = k_u \sqrt{2gH} = 0.46 \times \sqrt{2 \times 9.81 \times 479.5} \\ = 44.62 \text{ m/s}$$

$$\text{But, } u = \frac{\pi DN}{60}$$

$$\therefore N = \frac{60 \times 44.62}{\pi \times 1.2} = 710.1 \text{ rpm}$$

(iii) The maximum wheel efficiency is given by

$$(\eta_w)_{\max} = \frac{1 + k \cos \beta_2}{2} = \frac{1 + 0.9 \cos 15^\circ}{2} = 0.935$$

The maximum overall efficiency is given by

$$(\eta_o)_{\max} = \eta_n \times (\eta_w)_{\max} \times \eta_m \\ = C_v^2 \times (\eta_w)_{\max} \times \eta_m \quad (\because \eta_n = C_v^2) \\ = 0.98^2 \times 0.935 \times 0.92 \\ = 0.826$$

$$\therefore P_{\max} = (\eta_o)_{\max} \times \rho g Q H \\ = 0.826 \times 9810 \times \frac{\pi}{4} \times 0.08^2 \times 95.05 \times 479.5 \\ = 1.856 \text{ MW}$$

(iv) The theoretical runway speed is obtained corresponding to bucket speed equal to jet speed.

$$\therefore u_R = V$$

$$\text{i.e. } \frac{\pi DN_R}{60} = 95.05$$

$$N_R = \frac{95.05 \times 60}{\pi \times 1.2} = 1513 \text{ rpm}$$

**07(b).**

**Sol:**

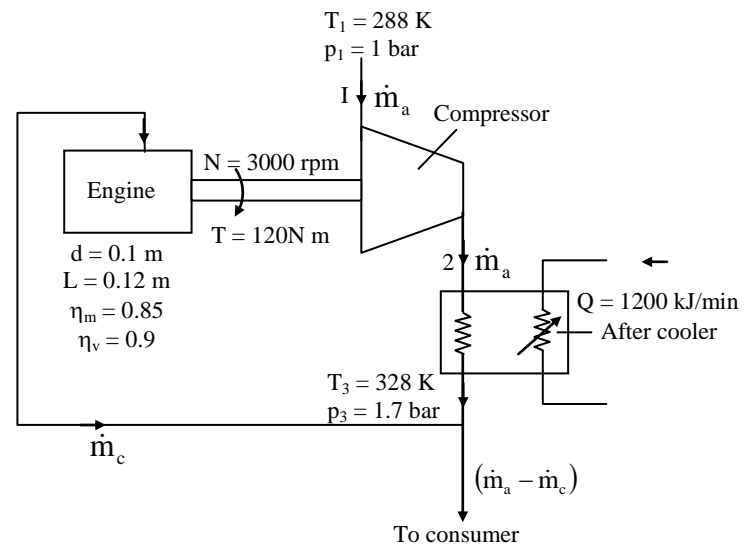

$$(i) \quad bp = \frac{2\pi NT}{60} = \frac{2\pi \times 3000 \times 120}{60 \times 1000} = 37.7 \text{ kW}$$

$$ip = \frac{bp}{\eta_m} = \frac{37.7}{0.85} = 44.35 \text{ kW}$$

$$ip = p_{eq} \frac{LAN}{2 \times 60} \times \text{no. of cylinders}$$

$$\text{Or, } 44.35 = p_{eq} \times 0.12 \times \frac{\pi}{4} (0.1)^2 \times \frac{3000}{120} \times 4 \times \frac{1}{10^3}$$

$$\therefore p_{eq} = \frac{44.35 \times 10^3 \times 4 \times 120}{0.12 \times \pi (0.1)^2 \times 3000 \times 4} \\ = 4.706 \times 10^5 \text{ N/m}^2 \\ = 4.706 \text{ bar}$$

$$(ii) \quad \text{Engine swept volume, } V_s = \frac{\pi}{4} d^2 L$$

Volume swept by the piston per min.

$$\dot{V}_s = \frac{\pi}{4} d^2 L \frac{N}{2} \times \text{no. of cylinders} \\ = \frac{\pi}{4} \times (0.1)^2 \times 0.12 \times \frac{3000}{2} \times 4 \\ = 5.655 \text{ m}^3/\text{min}$$

Rate of volume flow of air into the engine,

$$\dot{V} = \eta_v \times \dot{V}_s$$

$$= 0.9 \times 5.655 = 5.09 \text{ m}^3/\text{min}$$

Rate of mass flow of air into the engine

$$\dot{m} = \frac{p\dot{V}}{RT} = \frac{1.7 \times 10^5 \times 5.09}{287 \times 328} = 9.192 \text{ kg/min}$$

$$= 551.5 \text{ kg/h}$$

(iii) Power output of engine = Power absorbed by the compressor

$$= \text{gain in enthalpy per unit time in the compressor}$$

$$= \dot{m}_a (h_2 - h_1)$$

$$= \dot{m}_a c_{p_a} (T_2 - T_1)$$

$$\therefore \dot{m}_a \times 1.005(T_2 - 288) = 37.7 \text{ kJ/s} \quad \text{-----(1)}$$

where  $\dot{m}_a$  is in kg/s,

Energy balance in the after cooler

$$\dot{m}_a \times c_{p_a} (T_2 - T_3) = \frac{1200}{60} \text{ kJ/s}$$

$$\text{Or, } \dot{m}_a \times 1.005(T_2 - 328) = 20 \quad \text{-----(2)}$$

Dividing equation (1) by (2),

$$\frac{T_2 - 288}{T_2 - 328} = \frac{37.7}{20}$$

$$\therefore T_2 = 373.2 \text{ K}$$

From equation (1),

$$\dot{m}_a = \frac{37.7}{1.005 \times (373.2 - 288)} = 0.44 \text{ kg/s}$$

$$= 1584 \text{ kg/h}$$

Rate of air flow available to the consumer

$$= 1584 - 551.5 = 1032.5 \text{ kg/h}$$

**07(c).**

**Sol:**

$$(i) \text{ Mass of air} = \frac{101.325 \times (75 - 0.05)}{0.287 \times (273 + 6)}$$

$$= 94.84 \text{ kg}$$

$$\text{Mass of oil} = 950 \times 0.05 = 47.5 \text{ kg}$$

we take "air + oil" to be our system and room boundary as system boundary.

By first law of thermodynamics for closed system.

$$Q - W = \Delta U$$

Let the heater is switch on for t sec

$$-0.75 \times t - (-2.4 \times t) = 94.84 \times 0.717 \times (20 - 6) + 47.5 \times 2.2 \times (60 - 6)$$

$$\Rightarrow t = 3997 \text{ sec} = 66.6 \text{ minutes}$$

(ii) Exergy destruction =  $T_o \times S_{\text{gen}}$

$$S_{\text{gen}} = m_{\text{air}} \times c_v \ln\left(\frac{T_{fa}}{T_i}\right) + m_{\text{oil}} \times c \times \ln\left(\frac{T_{fo}}{T_i}\right) + \frac{\dot{Q} \times t}{T_o}$$

$$= 94.84 \times 0.717 \times \ln\left(\frac{293}{279}\right) + 47.5 \times 2.2 \times \ln\left(\frac{333}{279}\right) + \frac{0.75 \times 3997}{279}$$

$$= 3.33 + 18.49 + 10.74 = 32.56 \text{ kJ/K}$$

$$X_{\text{destroyed}} = 279 \times 32.56 = 9084.24 \text{ kJ}$$

(iii) Exergy supplied =  $2.4 \times 66.6 \times 60$

$$= 9590.4 \text{ kJ}$$

$$\text{Exergy destroyed} = 9084.24 \text{ kJ}$$

$$\eta_{\text{II}} = \frac{9590.4 - 9084.24}{9590.4} \times 100 = 5.28 \%$$

08(a).

Sol:

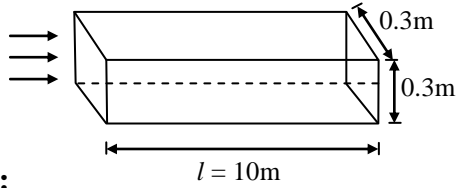

**Given :**

$$Pr = 0.695$$

$$\nu = 1.85 \times 10^{-5} \text{ m}^2/\text{s}$$

$$k = 0.028 \text{ W/m-K}$$

$$T_{\infty} = 25^{\circ}\text{C} = 298 \text{ K}$$

$$T_w = 65^{\circ}\text{C} = 338 \text{ K}$$

$$Gr = \frac{g \cdot \beta \cdot \Delta T \cdot L^3}{\nu^2}$$

$$= \frac{9.81 \times \left( \frac{1}{\frac{298 + 338}{2}} \right) \times (65 - 25) \times L^3}{(1.85 \times 10^{-5})^2}$$

$$Gr = 3.605 \times 10^9 \cdot L^3$$

$$(Ra)_L = Gr \cdot Pr$$

$$(Ra)_L = 2.505 \times 10^9 \cdot L^3$$

For upper and lower surfaces,

Characteristic length,

$$L = \frac{4A_s}{P} = \frac{4 \times 10 \times 0.3}{2(10 + 0.3)} = 0.5825 \text{ m}$$

$$L_{\text{top}} = L_{\text{bottom}} = 0.5825 \text{ m}$$

$$(RaL)_{\text{top}} = (RaL)_{\text{bottom}} = 495.257 \times 10^6$$

For both the vertical sides, characteristic

length,  $L_{\text{vertical}} = 0.3 \text{ m}$

$$(Ra)_{L,\text{side}} = 67.65 \times 10^6$$

Heat transfer from the top surface:

$$\bar{Nu} = 0.54(Ra_{aL})^{1/4}$$

$$= 0.54(495.257 \times 10^6)^{1/4} = 80.55$$

$$\frac{\bar{h} \cdot L_{\text{top}}}{k} = 80.55$$

$$\bar{h} = \frac{80.55 \times 0.028}{0.5825}$$

$$\bar{h} = 3.8722 \text{ W/m}^2 - \text{K}$$

$$Q_{\text{top}} = h \cdot A \cdot \Delta T$$

$$= 3.8722 \times 10 \times 0.3 \times (65 - 25)$$

$$Q_{\text{top}} = 464.67 \text{ W}$$

Heat transfer from bottom surfaces →

$$\bar{Nu} = 0.27(Ra_{aL})^{1/4}$$

$$= 0.27(495.257 \times 10^6)^{1/4}$$

$$\bar{Nu} = 40.27$$

$$\frac{\bar{h} \cdot L_{\text{bottom}}}{k} = 40.27$$

$$\bar{h} = 40.27 \times k$$

$$\bar{h} = \frac{40.27 L_{\text{bottom}} \times 0.028}{0.5825}$$

$$\bar{h} = 1.937 \text{ W/m}^2\text{K}$$

$$(Q)_{\text{bottom}} = \bar{h} \cdot A \cdot \Delta T$$

$$= 1.937 \times 10 \times 0.3 \times (65 - 25)$$

$$= 232.335 \text{ W}$$

Heat transfer from vertical sides

$$\bar{Nu} = 0.59(Ra_{aL})^{1/4}$$

$$= 0.59(67.65 \times 10^6)^{1/4}$$

$$\bar{Nu} = 53.509$$

$$\frac{\bar{h}}{k} = 53.509$$

$$\bar{h} = \frac{53.509 \times k}{L_{\text{vertical}}}$$

$$\bar{h} = \frac{53.509 \times 0.028}{0.3}$$

$$\bar{h} = 4.994 \text{ W/m}^2 - \text{K}$$

Heat transfer from both the vertical sides

$$Q = 2 \times \bar{h} \times A \times \Delta T$$

$$= 2 \times 4.994 \times 10 \times 0.3 \times (65 - 45)$$

$$Q_{\text{sides}} = 1198.60 \text{ W}$$

Total heat transfer from all the sides

$$Q_{\text{total}} = Q_{\text{top}} + Q_{\text{bottom}} + Q_{\text{vertical sides}}$$

$$= 464.67 + 232.335 + 1198.60$$

$$Q_{\text{total}} = 1895.605 \text{ W}$$

**08(b).**

**Ans: Windmill:** It is a device which converts the kinetic energy of wind into the mechanical energy of the turbine shaft. It is also called wind turbine,

### Classification of Windmills

Windmills are generally classified into five categories.

#### I. Based on the Axis of Rotation

##### (a) Horizontal Axis Machines

In horizontal axis machines, the direction of rotation of windmill is horizontal.

##### (b) Vertical Axis Machines

In vertical axis machines, the direction of rotation of windmill is vertical. In this type, the blades of the turbines are provided vertically as in case of ancient Persian windmill.

#### II. Based on the Size

##### (a) Small Scale

Small scale windmills produce electrical output upto 2 kW. These type of windmills are used on farms, remote applications and places where less power is required.

##### (b) Medium Scale

Medium scale windmills generate power at a range of 2–100 kW. These type of wind machines are especially applicable for local use.

##### (c) Large Scale

Large size windmills can generate more than 100 kW of electrical power. It is used for distributing the power in "central power grids". It can be divided into two groups such as,

- (i) Single generator at a single site
- (ii) Multiple generator at various sites over an area

#### III. Based on the Type of Output Generated

- (a) D.C output
- (b) A.C output

#### IV. Based on the Rotational Speed

- (a) Constant speed with variable pitch blades
- (b) Nearly constant speed with fixed pitch blades
- (c) Variable speed with fixed pitch blades

#### V. Based on the Utilization of Output Mode

- (a) Battery storage
- (b) Direct connection to an electromagnetic energy converter
- (c) Other forms of storage such as thermal potential etc.
- (d) Interconnection with conventional electric utility grids

The horizontal and vertical axis wind machines are briefly described as follows,

**1. Horizontal Axis Wind Mill (HAWM) working principle :**

1. It is a wind turbine in which the axis of the rotor's rotation is parallel to the wind stream and the ground. It is built with a propeller type rotor on a horizontal axis i.e, a horizontal main shaft. It may have two (or) three blades (or) more blades. The rotor converts linear motion of the wind into rotational energy that is used to drive a generator.

The basic principle is that the flow of air is parallel to the rotational axis of the turbine blades. The wind passes over both surfaces of the blade creating a lower pressure area above the air foil. The pressure differential between top and bottom surfaces results in aerodynamic lift. The blades of the turbine are constrained to move in a plane with the hub as its centre, the lift force causes rotation about the hub. In addition to lift force, a drag force perpendicular to lift force impedes rotor rotation. It has high lift-to-drag ratio.

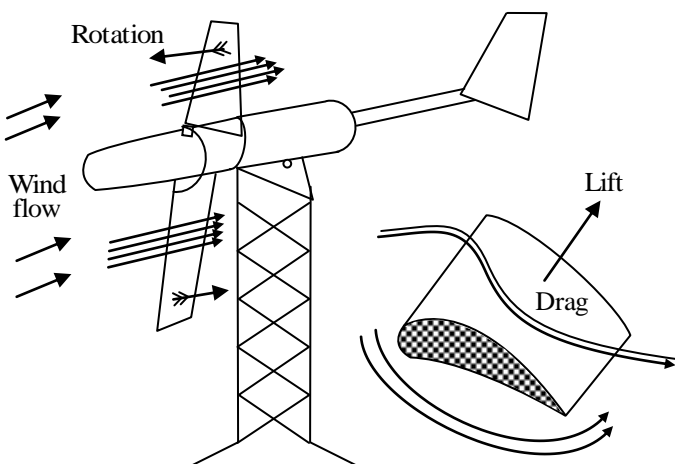

**2. Vertical Axis Wind Mill (VAWM) – working principle :**

A vertical axis wind mill is also known as "panemones" as shown in the figure. This type of wind mill is operated based on lift and drag devices. The devices such as plates, cups and wind turbines are used in the vertical axis wind mills. An example of vertical axis wind machine is a cup anemometer which consists of concave and convex surfaces. When the direction of wind acts towards concave surface, more drag is produced, as a result of this anemometer rotates. When the anemometer passes across the wind, it undergoes a little amount of force (lift) and due to their convex surfaces wind gets deflected and reduced in pressure. The main function of cup anemometer is to rotate the rotor within a limited range of tip speed ratio which makes its rotational speed nearly equivalent to wind speed. The major advantage of vertical axis wind mill is that, it does not turn into windstream as the direction of wind changes.

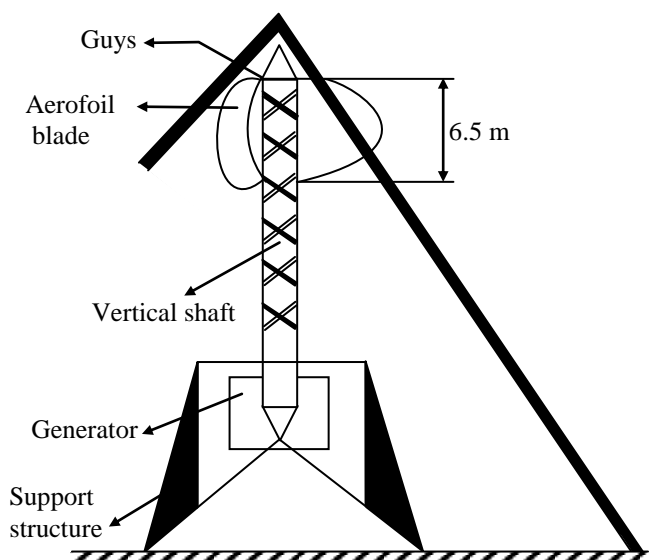



08(c).

Sol:

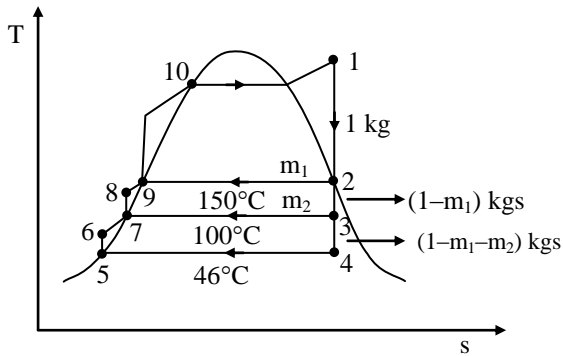

At 20 bar,  $T_{sat} = 212^\circ\text{C}$

At 0.1 bar,  $T_{sat} = 46^\circ\text{C}$

(i) At 20 bar,  $300^\circ\text{C}$  :

$$h_1 = 3023.5 \text{ kJ/kg},$$

$$s_1 = 6.7664 \text{ kJ/kgK},$$

$$s_1 = s_2 = s_3 = s_4$$

Temperature difference between feedwater heater

$$= \frac{(T_{sat})_{boil} - (T_{sat})_{con}}{n + 1}$$

Here,  $n = 2$  feed water heaters

$$dT = \frac{212 - 46}{2 + 1} = 55^\circ\text{C}$$

Temperature of first feed water heater

$$= (T_{sat})_{boil} - dT = 212 - 55$$

$$= 157^\circ\text{C} \approx 150^\circ\text{C} \text{ (assumed)}$$

Temperature of second feed water heater

$$= (T_{sat})_{boil} - 2 dT = 212 - 2 \times 55$$

$$= 102^\circ\text{C} \approx 100^\circ\text{C} \text{ (assumed)}$$

Assumptions are made based on data values given in steam tables in the problem.

$$s_1 = s_2 = 6.7664 < s_g \text{ at } 150^\circ\text{C}$$

hence is wet state

$$s_1 = s_{f2} + x_2(s_{g2} - s_{f2})$$

$$6.7664 = 1.8418 + x_2(6.7664 - 1.8418)$$

$$x_2 = 0.986$$

$$h_2 = h_{f2} + x_2(h_{g2} - h_{f2})$$

$$= 632.2 + 0.986(2114.3) = 2716.9 \text{ kJ/kg}$$

$$s_1 = s_3 = 6.7664 < s_g \text{ at } 100^\circ\text{C} \rightarrow \text{wet state}$$

$$s_1 = s_{f3} + x_3(s_{g3} - s_{f3})$$

$$6.7664 = 1.3069 + x_3(6.048)$$

$$x_3 = 0.903$$

$$h_3 = h_{f3} + x_3(h_{g3} - h_{f3})$$

$$= 191.83 + 0.903(2257) = 2457.1 \text{ kJ/kg}$$

$$s_1 = s_4 = 6.7664 < s_g \text{ at } 46^\circ\text{C} \rightarrow \text{wet state}$$

$$s_1 = s_{f4} + x_4(s_{g4} - s_{f4})$$

$$6.7664 = 0.6493 + x_4(7.501)$$

$$x_4 = 0.816$$

(ii)  $h_4 = h_{f4} + x_4(h_{g4} - h_{f4})$

$$= 191.83 + 0.816(2392.8) = 2144.3 \text{ kJ/kg}$$

As pump work is neglected

$$h_{10} = h_9, \quad h_8 = h_7, \quad h_6 = h_5$$

Energy balance for feed water heater (2) HP heater

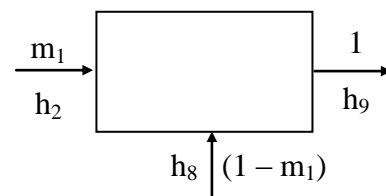

$$m_1 h_2 + (1 - m_1) h_8 = h_9$$

$$m_1 = \frac{h_9 - h_8}{h_2 - h_8}$$

$$= \frac{632.2 - 419.04}{2716.9 - 419.04} = 0.093 \text{ kg}$$



$$h_9 = (h_f)_{150^\circ\text{C}} = 632.2 \text{ kJ/kg}$$

$$h_8 = (h_f)_{100^\circ\text{C}} = 419.04 \text{ kJ/kg}$$

$$h_6 = (h_f)_{46^\circ\text{C}} = 191.83 \text{ kJ/kg}$$

Energy balance for feed water heater (1) LP heater

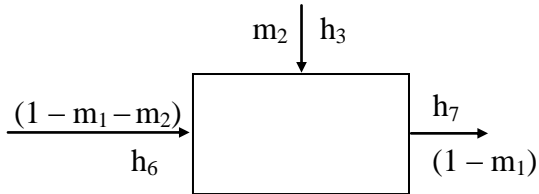

$$(1 - m_1 - m_2) h_6 + m_2 h_3 = (1 - m_1) h_7$$

$$(1 - m_1) h_6 + m_2 (h_3 - h_6) = (1 - m_1) h_7$$

$$m_2 (h_3 - h_6) = (1 - m_1) (h_7 - h_6)$$

$$m_2 = \frac{(1 - m_1)(h_7 - h_6)}{(h_3 - h_6)}$$

$$= \frac{(1 - 0.093)(419.04 - 191.83)}{(2457.1 - 191.83)}$$

$$= 0.091 \text{ kgs}$$

$$W_T = 1 (h_1 - h_2) + (1 - m_1) (h_2 - h_3) + (1 - m_1 - m_2) (h_3 - h_4)$$

$$= 1 (3023.5 - 2716.9) + (1 - 0.093)(2716.9 - 2457.1) + (1 - 0.093 - 0.091) (2457.1 - 2144.3)$$

$$W_T = 797.48 \text{ kJ/kg}$$

(iii) Heat supplied,

$$Q_1 = h_1 - h_9 = 3023.5 - 632.2$$

$$= 2391.3 \text{ kJ/kg}$$

$$\eta_{\text{cycle}} = \frac{W_T - W_P}{Q_1}$$

$$= \frac{797.48 - 0}{2391.3} = 0.3334 \text{ or } 33.34\%$$

$$(iv) \text{ Steam rate} = \frac{3600}{W_{\text{net}}}$$

$$= \frac{3600}{797.48} = 4.514 \text{ kJ/kWhr}$$