



CIVIL ENGINEERING



GATE | PSUs

STRUCTURAL ANALYSIS

Volume - I : Study Material with Classroom Practice Questions

Structural Analysis

Solutions for Volume : I Classroom Practice Questions

Chapter- 1 Introduction to Structures & Static Indeterminacy

Class Room Practice Solutions

01. Ans: (d)

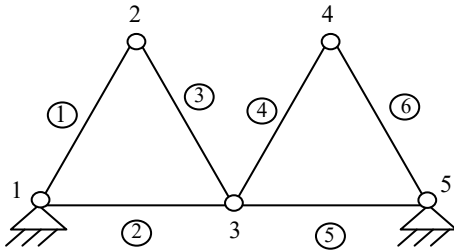

(i) $r = 4; j = 5; m = 6;$

$$D_{se} = 4 - 3 = 1$$

$$\begin{aligned} D_{si} &= m - (2j - 3) \\ &= 6 - (2 \times 5 - 3) \\ &= 6 - 7 = -1 \end{aligned}$$

The given truss is internally unstable.

(ii) $D_{se} = r - 3 \quad j = 9, m = 14$

$$= 6 - 3 = 3$$

$$\begin{aligned} D_{si} &= m - (2j - 3) \\ &= 14 - (18 - 3) = -1 \end{aligned}$$

The given frame is internally unstable.

(iii) All supports are roller,

\therefore The given truss is unstable.

(iv)

$$D_{se} = 4 - 3 = 1$$

$$\begin{aligned} D_{si} &= m - (2j - 3) \\ &= 15 - (20 - 3) \\ &= 15 - 17 = -2 \end{aligned}$$

Internally unstable.

(v) In a member, there should not be more than two internal hinges.

02. Ans: (a)

Sol: $j = 6 ; D_{se} = 4 - 3 = 1$

$$\begin{aligned} m &= 8 ; D_{si} = m - (2j - 3) \\ &= 8 - (12 - 3) \\ &= -1 \end{aligned}$$

$$\text{Total Indeterminacy} = 1 - 1 = 0$$

Note: The extra horizontal reaction available at support will give stability by triangular behaviour.

03. Ans: (b)

Sol: $j = 9 ;$

$$m = 16;$$

$$D_{se} = 3 - 3 = 0$$

$$\begin{aligned} D_{si} &= m - (2j - 3) \\ &= 16 - (2 \times 9 - 3) \\ &= 16 - 15 = 1 \end{aligned}$$

Stable but indeterminate by one



04. Ans: (c)

Sol: $D_{se} = 0$;

$$D_{si} = m - (2j - 3) = 9 - (2 \times 6 - 3) = 0$$

∴ The frame is internally as well as externally determinate.

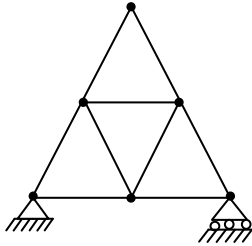

05. Ans: (a)

Sol:

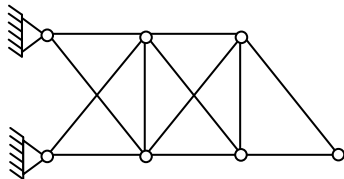

As the two supports are hinged total no. of reactions = 4.

The deficiency of vertical member between the supports is taken care of by the additional vertical reaction. Hence the structure is stable. Hence D_{se} can be taken as zero.

$D_{si} = 2$ (additional members in the first two spans more than required for stability)

$$D_{se} = 2$$

06. Ans: (b)

Sol:

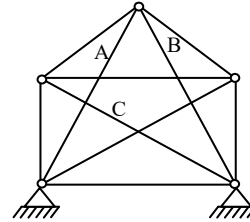

$$D_{se} = 2 + 2 - 3 = 1$$

$$D_{si} = m - (2j - 3) = 10 - (2 \times 5 - 3) = 3$$

$$D_s = 3 + 1 = 4$$

Note: This is formula for internal indeterminacy of pin jointed plane trusses. We know that the basic perfect shape for pin jointed truss is triangle either by shape or by behaviour. Hence by removing three members suitably (A, B & C as shown in figure), the stability can be maintained.

$$D_s = 1 + 3 = 4$$

07. Ans: 19

Sol:

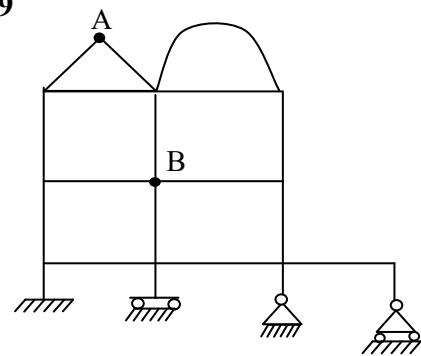

$$\text{Number of reactions} = 3 + 2 + 2 + 1 = 8$$

$$\text{Equilibrium equations} = 3$$

$$D_{se} = 8 - 3 = 5$$

$$D_{si} = 3c = 3 \times 6 = 18$$

$$\text{Force releases at A} = n - 1 = 2 - 1 = 1$$

$$\text{Force releases at B} = n - 1 = 4 - 1 = 3$$



Where,

n = number of members joining at that location.

$$D_s = D_{se} + D_{si} - \text{no. of force releases}$$

$$= 5 + 18 - 1 - 3 = 19$$

08. Ans: (d)

Sol:

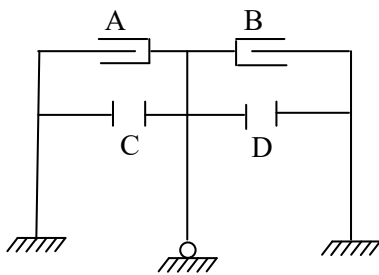

$$\text{No. of reactions}(r) : 3 + 2 + 3 = 8$$

$$D_{se} = r - 3$$

$$D_{se} = 8 - 3 = 5$$

$$D_{si} = 3 \times \text{no. of closed boxes} = 3c = 3 \times 2 = 6$$

$$\text{force releases} = (1 + 1 + 1 + 1) = 4$$

$$D_s = D_{se} + D_{si} - \text{no. of force releases}$$

$$= 5 + 6 - 4 = 7$$

Note: A & B are horizontal shear releases.

At each of them one force is released.

C & D are vertical shear releases.

At each of them one force is released.

09. Ans: (a)

Sol:

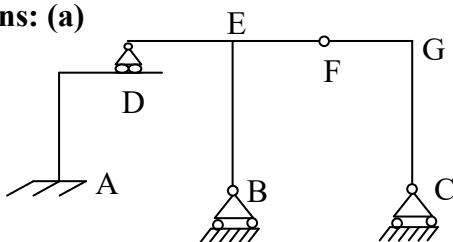

$$D_{se} = (3 + 2 + 1) - 3 = 3$$

$$D_{si} = 0$$

$$\text{Force release at 'D'} = 2$$

$$\text{Force release at 'F'} = 1$$

$$\therefore D_s = 3 + 0 - 2 - 1 = 0$$

10. Ans: (b)

Sol:

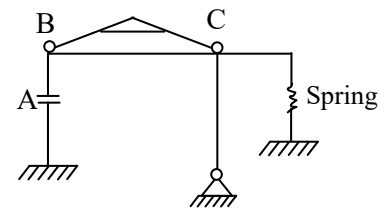

$$\text{Reaction at fixed support} = 3$$

$$\text{Reaction at hinged support} = 2$$

$$\text{Reaction at spring support} = 1$$

$$\text{Total reactions} = 6$$

$$D_{se} = 6 - 3 = 3$$

$$D_{si} = 3 \times 2 = 6$$

$$\text{Horizontal force release at 'A'} = 1$$

$$\text{Moment releases at 'B'} = 1$$

$$\text{Moment releases at 'C'} = 1$$

Note: At B and C the hinges are tangential to the horizontal beam. Hence the column and beam will have only one common rotation.

$$D_s = 3 + 6 - 1 - 1 - 1 = 6$$

11. Ans: (b)

Sol:

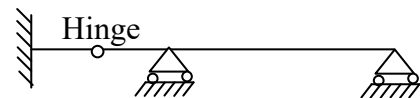

$$\text{No. of reactions}(r) = 3 + 1 + 1 = 5$$

$$\text{No. of eq. eqns (E)} = 3$$

$$\text{Force releases} = 1$$

$$D_{si} = 0$$

$$D_s = 5 - 3 - 1 = 1$$



12. Ans: Zero

Sol: The given truss is statically determinate. Determinate structures are not subjected to stresses by lack of fit, temperature change, sinking of supports etc.

Chapter- 2
Kinematic Indeterminacy

Class Room Practice Solutions

01. Ans: (b)

Sol:

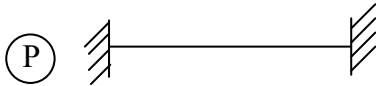

$$D_k = 3j - r \quad D_s = (3m + r) - 3j$$

$$j = 2, r = 6 \quad = 3 + 6 - (3 \times 2)$$

$$D_k = 6 - 6 = 0 \quad D_s = 9 - 6 = 3 \quad D_k = 0 \quad D_s = 3$$

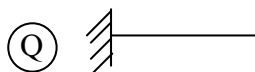

$$D_s = r - 3 = 3 - 3 = 0$$

$$D_k = 3j - r = (3 \times 2) - 3 = 3$$

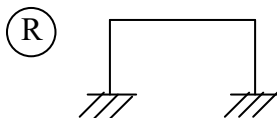

$$D_s = 0 \quad D_k = 3$$

$$j = 4, m = 3, r = 6$$

$$D_s = r - 3$$

$$= 6 - 3 = 3$$

$$D_k = 3j - r = 3 \times 4 - 6 = 6$$

02. Ans: (b)

Sol:

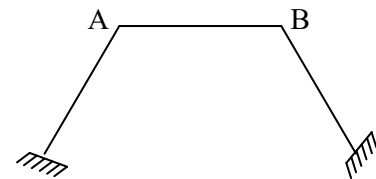

A & B are rigid joints.

The rigid joint of a plane frame will have three degrees of freedom.

Fixed supports will have zero degrees of freedom.

∴ Total number of degrees of freedom = 6 (considering axial deformations)

No. of members = 3

Neglecting axial deformations, degrees of freedom or kinematic indeterminacy

$$D_k = 6 - 3 = 3$$

or

Using the formula

$$D_k = 3j - r$$

$$= 3 \times 4 - 6 = 6 \text{ (with axial deformations)}$$

$$= 6 - 3 = 3 \text{ (Neglecting axial deformations)}$$

Note: While using the formula supports also shall be treated as joints.



03. Ans: (b)

Sol:

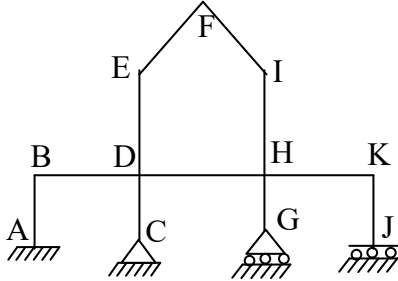

D.O.F of rigid joints = $7 \times 3 = 21$
 D.O.F of fixed support = 0
 D.O.F of hinged support = 1
 D.O.F of roller support = 2
 D.O.F of horizontal shear release support = 1
 Total D.O.F or $D_k = 21 + 0 + 1 + 2 + 1 = 25$
 (Considering axial deformations)
 Neglecting axial deformations = $25 - 11 = 14$

04.

Sol:

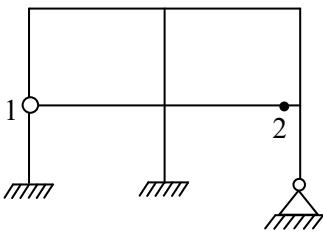

D.O.F of four rigid joints = $4 \times 3 = 12$
 D.O.F of hinged joint '1' = 5
 (three rotations and two translations)
 D.O.F of joint 2 = 4 (two rotations and two translations. Both vertical members will have one common rotation)

D.O.F of fixed supports = 0
 D.O.F of hinged support = 1
 Total D.O.F or $D_k = 12 + 5 + 4 + 1 = 22$
 (considering axial deformations)
 Neglecting axial deformations = $22 - 10 = 12$

05. Ans: 9 or 5

Sol:

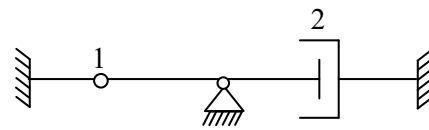

D.O.F of moment release at '1' = 4
 D.O.F of horizontal shear release at '2' = 4
 D.O.F of fixed support = 0
 D.O.F of hinged support = 1
 Total D.O.F or $D_k = 4 + 4 + 1 = 9$
 (considering axial deformations)
 Neglecting axial deformations = $9 - 4 = 5$

06. Ans: 20 or 13

Sol:

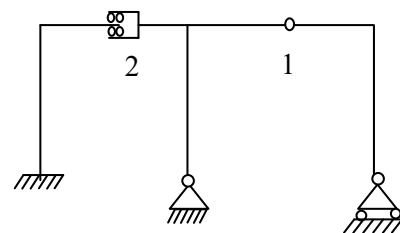

D.O.F of moment release at '1' = 4
 D.O.F of horizontal shear release at '2' = 4
 D.O.F of 3 rigid joints = $3 \times 3 = 9$
 D.O.F of fixed support = 0
 D.O.F of hinged support = 1
 D.O.F of roller support = 2



Total D.O.F or $D_k = 4 + 4 + 9 + 1 + 2 = 20$
(considering axial deformations)
Neglecting axial deformations $= 20 - 7 = 13$

07. Ans: 9 or 5

Sol:

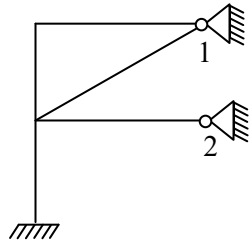

D.O.F of 2 rigid joints $= 2 \times 3 = 6$
D.O.F of fixed support $= 0$
D.O.F of hinged support '1' $= 2$
(Two members are connected to the hinged support '1'. Hence two different rotations are possible)
D.O.F of hinged support '2' $= 1$
Total D.O.F or $D_k = 6 + 0 + 2 + 1 = 9$
(considering axial deformations)
Neglecting axial deformations $= 9 - 4 = 5$

Note: The effect of diagonal member shall not be considered.

Note: At hinged support '1' two rotations, at hinged support '2' one rotation, at each rigid joint one rotation. No sway. Hence five D.O.F neglecting axial deformations.

08. Ans: 6 or 3

Sol:

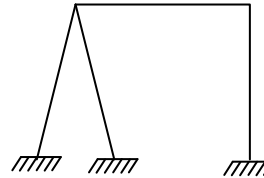

D.O.F of two rigid joints $= 2 \times 3 = 6$
D.O.F of fixed support $= 0$
Total D.O.F or $D_k = 6 + 0 = 6$
(Considering axial deformations)
Neglecting axial deformations $= 6 - 3 = 3$

Note: The effect of two inclined members shall be taken as one member.

Note: At each rigid joint one independent rotation + one sway of the frame as a whole.

09. Ans: 4 or 2

Sol:

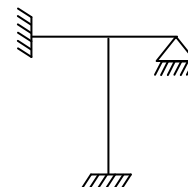

D.O.F of 1 rigid joint $= 1 \times 3 = 3$
D.O.F of fixed supports $= 0$
D.O.F of hinged support $= 1$
Total D.O.F or $D_k = 3 + 1 = 4$
(Considering axial deformations)
Neglecting axial deformations $= 4 - 2 = 2$

Note: As no sway the axial deformation of two beams shall be taken as one.

Note: At rigid joint one independent rotation + one rotation at hinged support.



10. Ans: 13

Sol: For pin jointed plane frame $D_k = 2j - r$
 $= 2(8) - 3$
 $= 13$

11. Ans: (b)

Sol:

$j = 6, r = 3,$
 $D_k = 2j - r$
 $= 2 \times 6 - 3 = 9$
 $D_{se} = r - 3 = 3 - 3 = 0$
 $D_{si} = m - (2j - r)$
 $= 9 - (2 \times 6 - 3)$
 $D_s = D_{se} + D_{si}$
 $= 0$

\therefore Statically determinate and kinematically indeterminate by 9.

Chapter- 3
Statically Determinate Frames

Class Room Practice Solutions

Sign convention for forces

Axial compression: A compression member will push the joint to which it is connected.



Axial tension: A tension member will pull the joint to which it is connected



01. Ans: (d)

Sol:

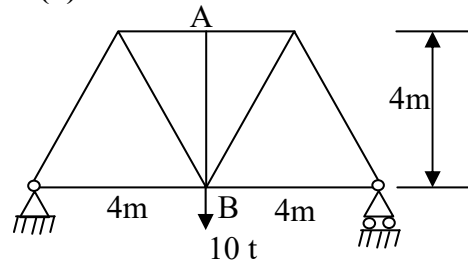

Analyzing at 'A', two forces are in the same line, hence the 3rd force AB is zero.

02. Ans: (a)

Sol:

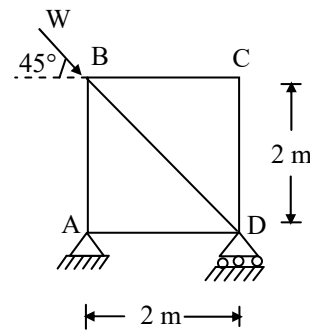

At 'C' the two forces not in the same line, hence $F_{CD} = F_{CB} = 0$

Now analyzing at 'B' $F_{BA} = 0$

03. Ans: (c)

Sol:

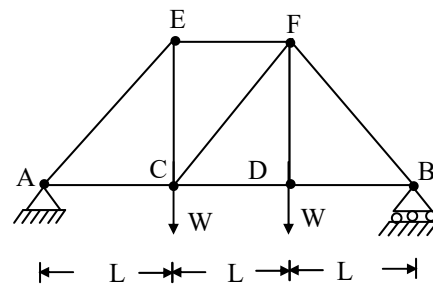

$F_{DC} = F_{DB}$
 $F_{CA} = F_{CD}$
 $F_{CE} = W$
 $\therefore F_{CF} = 0$



04. Ans: (c)

Sol: First analyze at 'E'.

$$\therefore F_{EC} = 0$$

Now analyze at 'C'.

$$\therefore F_{CA} = 0$$

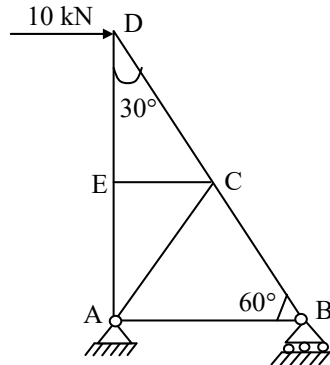

05. Ans: (c)

Sol:

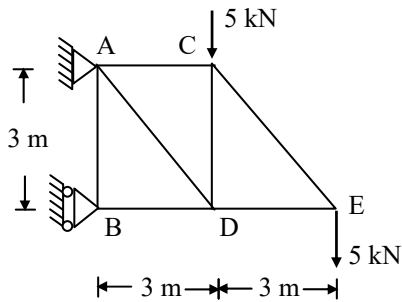

At roller support the reaction is horizontal which is in line with BD

$$\therefore F_{AB} = 0$$

06. Ans: (b)

Sol:

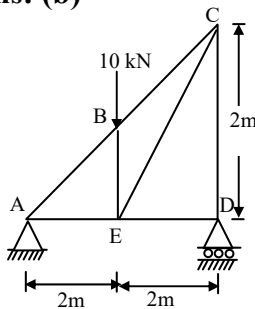

$$R_D = 5 \text{ kN } \uparrow \therefore F_{CD} = 5 \text{ kN}$$

At 'D' as reaction is normal to the plane of rolling and DC and the vertical reaction are in the same line then $F_{DE} = 0$

$$F_{BE} = 10 \text{ kN}$$

07. Ans: (a)

Sol:

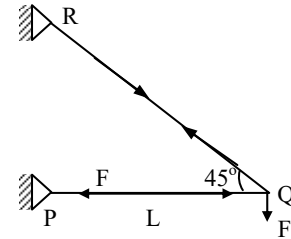

Apply $\Sigma V = 0$ at Q.

$$F_{QR} \sin 45^\circ = F$$

$$\Rightarrow F_{QR} = F\sqrt{2} \text{ (tension)}$$

Now apply $\Sigma H = 0$ at Q.

$$F_{QR} \cdot \cos 45^\circ = F_{QP}$$

$$F\sqrt{2} \times \frac{1}{\sqrt{2}} = F_{QP}$$

$$\therefore F_{QP} = F \text{ (compression).}$$

08. Ans: (c)

Sol:

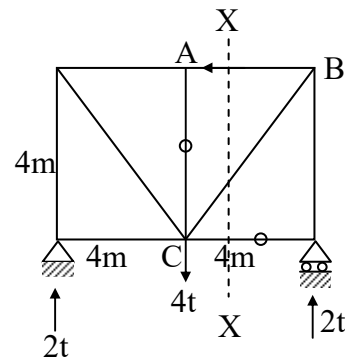

Using method of sections. Pass a section X - X as shown through the chosen member AB and other two members so that these two



other members pass through a common joint say 'C'.

Consider left side of the section.

Apply $\Sigma M = 0$ for the left side of the section.

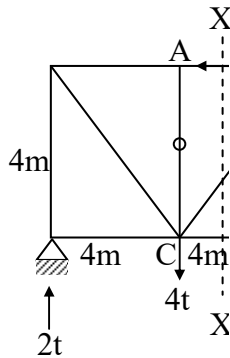

$$2t \times 4 = f_{AB} \times 4$$

$$\therefore f_{AB} = 2t \text{ (Comp)}$$

09. Ans: (a)

Sol:

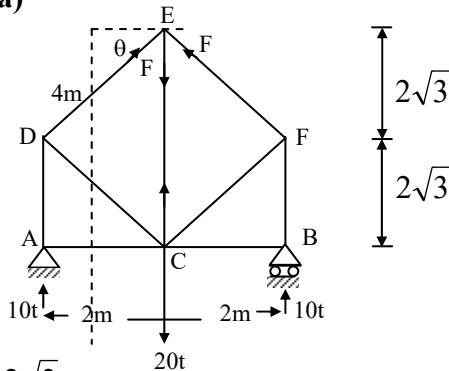

$$\tan \theta = \frac{2\sqrt{3}}{2}$$

$$\therefore \theta = 30^\circ$$

Pass the section as shown in figure

Apply $\Sigma M_C = 0$ for the right part of the section.

$$\Rightarrow 10 \times 2 = F \cos 30^\circ \times \frac{4}{\sqrt{3}}$$

$$\therefore F = 10t$$

Now analysis at joint E.

$$\Sigma F_y = 0 \Rightarrow 2F \sin 30^\circ = F_{CE}$$

$$2 \times 10 \times \frac{1}{2} = F_{CE}$$

$$F_{CE} = 10t \text{ (tension)}$$

10. Ans: (c)

Sol:

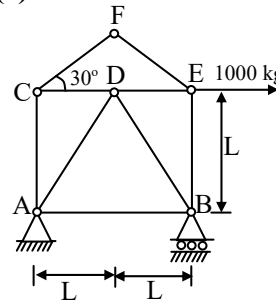

Consider joint F.

We know that if two members act at a joint and if they are not in the same line then each of them are zero.

Hence,

F_{CF} , F_{EF} both are zero.

Similarly Consider joint C.

$\therefore F_{CD}$, F_{CA} both are zero

Taking $\Sigma M_B = 0$, $R_A = 500$ (\downarrow)

Joint (A)

$$F_{AD} \sin 45 = R_A$$

$$\therefore F_{AD} = 500\sqrt{2} \text{ (tension)}$$



11. Ans: (c)

Sol:

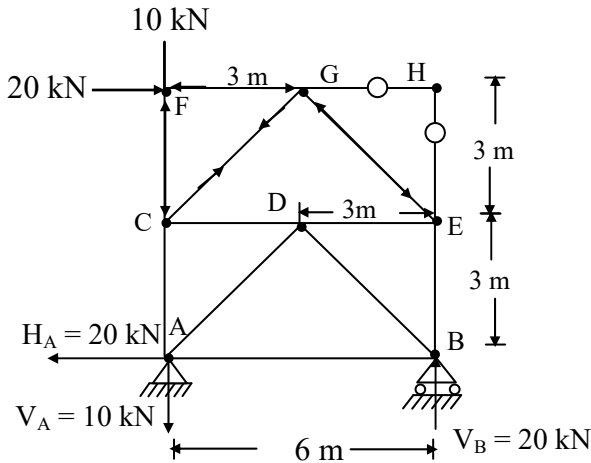

Reactions are $V_A = 10 \text{ kN} \downarrow$,

$H_A = 20 \text{ kN} \leftarrow$

$V_B = 20 \text{ kN} \uparrow$

$F_{HG} = F_{HE} = 0$

Apply $\Sigma V = 0$ at 'G'

$\therefore F_{AC} = F_{AE}$

Apply $\Sigma H = 0$

$F_{GE} \cos 45^\circ + F_{CG} \cos 45^\circ = 20$

$\therefore 2F_{GC} \cos 45^\circ = 20$

$F_{GC} = 10\sqrt{2}$ (tensile)

Apply $\Sigma V = 0$ @ C

$\Rightarrow F_{CA} = 0$

12. Ans:

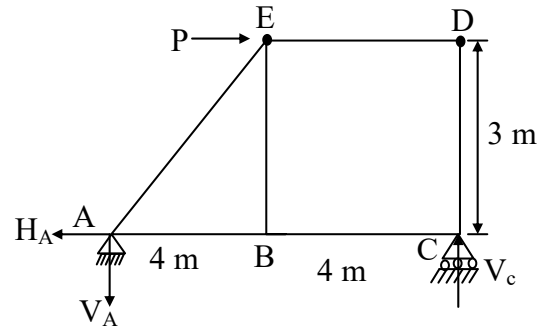

$\Sigma m_c = 0$

$P \times 3 - V_A \times 8 = 0$

$V_A = \frac{3P}{8}$

$\Sigma F_y = 0$

$V_A = V_C = \frac{3P}{8}$

Joint A

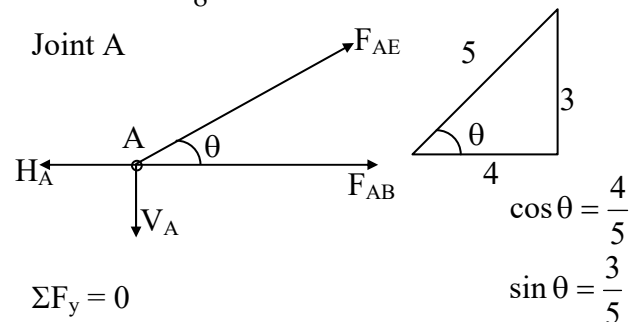

$\Sigma F_y = 0$

$F_{AE} \sin \theta - V_A = 0$

$F_{AE} \times \frac{3}{5} - V_A = 0$

$F_{AE} = \frac{3P}{8} \times \frac{5}{3} = \frac{5P}{8}$

$\Sigma F_x = 0$

$F_{AB} + F_{AE} \cdot \cos \theta - P = 0$

$F_{AB} = \frac{P}{2}$



Joint (E)

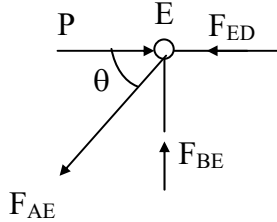

$$\Sigma F_X = 0$$

$$F_{BE} - F_{AE} \cdot \sin \theta = 0$$

$$F_{BE} = \frac{5P}{8} \times \frac{3}{5} = \frac{3P}{8}$$

$$F_{AB} : F_{BE} : F_{AE}$$

$$\frac{P}{2} : \frac{3P}{8} : \frac{5P}{8} = 4 : 3 : 5$$

13. Ans: (b)

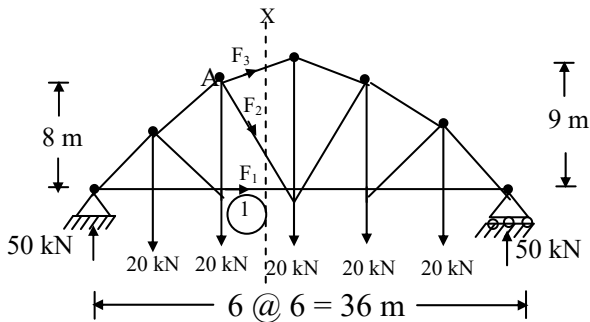

Taking left side

$$\Sigma M_A = 0$$

$$50 \times 12 - 20 \times 6 - F_1 \times 8 = 0$$

$$F_1 = 60 \text{ kN}$$

Chapter- 4 Basic Methods of Structural Analysis

Class Room Practice Solutions

01. Ans: (d)

Sol:

- Stiffness method deals with unknown joint displacement (degrees of freedom). It is nothing but kinematic Indeterminacy. Hence stiffness method is more suitable if kinematic Indeterminacy is less than static indeterminacy. As displacements are unknowns it is also called displacement method.
- Equilibrium equations are used at joints to analyze the structure. Hence it is also called equilibrium method.

02. Ans: (a)

Sol: Force methods, deal with unknown redundant forces. In pin jointed trusses, more number of degrees of freedom. Hence stiffness methods are complicated compare to force method.

03. Ans: (b)

Sol: In theorem of three moments, consistent deformation method unknown forces are dealt with. Hence these are force methods
Moment distribution and slope deflection method deal with displacements. Hence these are displacement methods.



04. Ans: (c)

Sol:

In Force methods, forces are kept unknowns and unknown forces are found by using geometric compatibility conditions.

In displacement methods, joint displacements are kept as unknowns and joint equilibrium conditions are enforced to find unknown displacements.

05. Ans: (b)

Sol:

Description	Option
Kani's method is very much suitable for multistorey frames	∴ A-4
Force method suitable if static indeterminacy is less.	∴ B-3
Column analogy method suitable for box frames with varying sections and inclined members	∴ C-1
Displacement method suitable if Kinematic Indeterminacy is less	∴ D-2

Chapter- 5
Energy Principles

Class Room Practice Solutions

01. Ans: (d)

Sol: Vertical deflection @ C

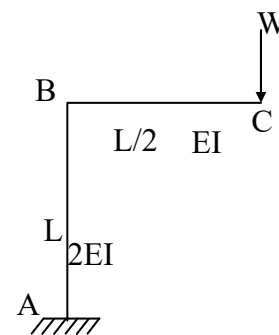

FBD of BC:

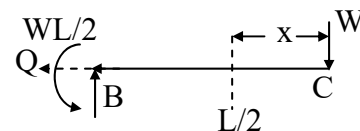

$$M_x = + WX$$

$$\frac{\partial M_x}{\partial W} = X$$

$$\delta_{vBC} = \frac{1}{EI} \int_0^{L/2} M_x \frac{\partial M_x}{\partial W} dx$$

$$= \frac{1}{EI} \int_0^{L/2} (WX)(X) dx$$

$$= \left[\frac{WX^3}{3EI} \right]_0^{L/2}$$

$$= \frac{WL^3}{24EI}$$

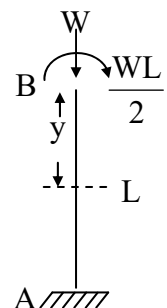



FBD of AB:

$$M_y = \frac{WL}{2}$$

$$\frac{\partial M_y}{\partial W} = \frac{L}{2}$$

$$\begin{aligned} \delta_{VAB} &= \frac{1}{2EI} \int_0^L \left(\frac{WL}{2} \right) \left(\frac{1}{2} \right) dy \\ &= \frac{1}{2EI} \frac{WL^2}{4} y \int_0^L = \frac{WL^3}{8EI} \end{aligned}$$

Total vertical deflection at

$$\delta_c = \frac{WL^3}{24EI} + \frac{WL^3}{8EI} = \frac{WL^3}{6EI}$$

02. Ans: (b)

Sol: Horizontal deflection at C

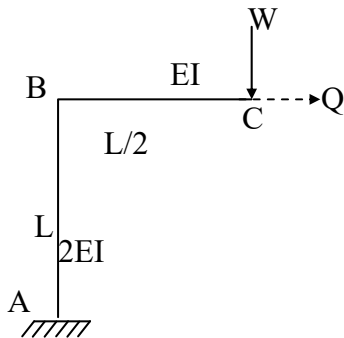

FBD of BC:

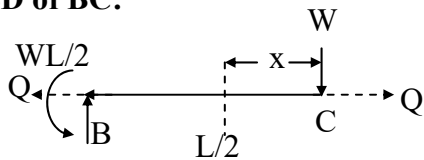

$$M_x = + WX$$

$$\frac{\partial M_x}{\partial Q} = 0$$

$$\delta_{hBC} = \frac{1}{EI} \int_0^{L/2} (WX)(0) dx = 0$$

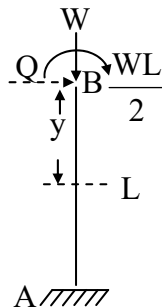

FBD of AB:

$$M_y = \frac{WL}{2} + Qy$$

$$\frac{\partial M_y}{\partial Q} = +y$$

$$\begin{aligned} \delta_{hAB} &= \frac{1}{2EI} \int_0^L \left(\frac{WL}{2} + Qy \right) (y) dy \\ &= \frac{1}{2EI} \int_0^L \left(\frac{WL}{2} \right) (y) dy \end{aligned}$$

(Q= 0 as it is imaginary force)

$$= \frac{1}{2EI} \left(\frac{WL}{2} \right) \left(\frac{y^2}{2} \right)_0^L = \frac{WL^3}{8EI}$$

$$\text{Total horizontal deflection} = \frac{WL^3}{8EI}$$

03. Ans: (c)

Sol:

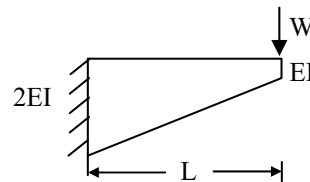

Shortcut: Strain energy is inversely proportional to I.

$$\text{With uniform I, } U = \frac{w^2 l^3}{6EI}$$

$$\text{With uniform 2I, } U = \frac{w^2 l^3}{12EI}$$

As given has I varying from I to 2I, denominator shall be in between 6 and 12.



Traditional procedure:

$$M_x = wx$$

$$I_x = I + \frac{I \cdot x}{l}$$

$$= I \left(1 + \frac{x}{l} \right) = \frac{I(l+x)}{l}$$

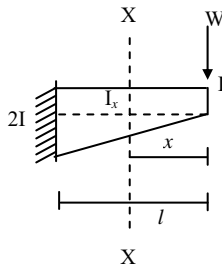

$$U = \int_0^l \frac{w^2 x^2 \cdot dx}{2E \frac{I(l+x)}{l}}$$

$$= \int_0^l \frac{lw^2 x^2 dx}{2EI(l+x)}$$

$$= \frac{w^2 l}{2EI} \int_0^l \frac{x^2}{l+x} dx$$

$$= \frac{w^2 l}{2EI} \int_0^l \frac{x^2 - l^2 + l^2}{l+x} dx$$

$$= \frac{w^2 l}{2EI} \left[\int_0^l \frac{(x+l)(x-l)}{(l+x)} dx + \int_0^l \frac{l^2}{(l+x)} dx \right]$$

$$= \frac{w^2 l}{2EI} \left[\left(\frac{x^2}{2} - lx \right)_0^l + (l^2 \log(l+x))_0^l \right]$$

$$= \frac{w^2 l}{2EI} \left[\frac{l^2}{2} - l^2 + l^2 \log_e 2l - l^2 \log_e l \right]$$

$$= \frac{w^2 l}{2EI} \left[\frac{-l^2}{2} + l^2 \log_e \frac{2l}{l} \right]$$

$$= \frac{w^2 l}{2EI} \left[-0.5l^2 + l^2 (0.693) \right]$$

$$U = \frac{w^2 l^3}{10.35 EI}$$

04. Ans: (b)

Sol: $M_x = W R \sin \theta$

$$\frac{\partial M}{\partial W} = R \sin \theta$$

$$\delta H_B = \frac{1}{EI} \int_0^\pi W R \sin \theta \times R \sin \theta \times R d\theta$$

$$= \frac{WR^3}{EI} \int_0^\pi \sin^2 \theta d\theta$$

$$\therefore \sin^2 \theta = \frac{1 - \cos 2\theta}{2}$$

$$= \frac{WR^3}{EI} \int_0^\pi \left(\frac{1 - \cos 2\theta}{2} \right) d\theta$$

$$= \frac{WR^3}{EI} \left(\frac{\theta}{2} - \frac{\sin 2\theta}{2} \right)_0^\pi$$

$$\delta H_B = \frac{\pi WR^3}{2EI}$$



05. Ans: (c)

Sol: Consider free body diagram Of 'AB'

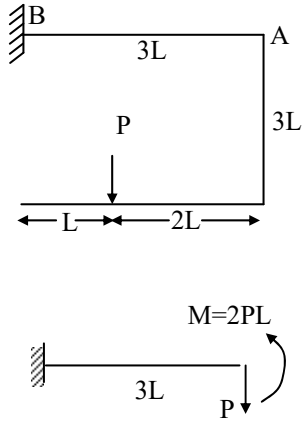

$$\delta_{vA} = \frac{P(3L)^3}{3EI} - \frac{(2PL)(3L)^2}{2EI} = 0$$

06. Ans: (a)

Sol:

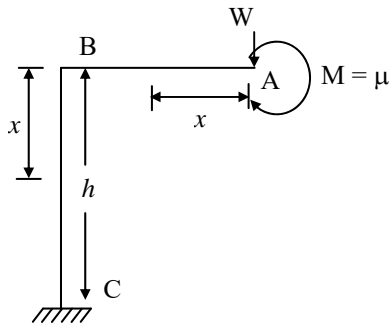

For member AB

$$M_x = M_z + M$$

$$\frac{\partial M_x}{\partial W} = x$$

$$\delta_v = \int M_x \frac{\partial M_x}{\partial W} \cdot \frac{dx}{EI}$$

$$\delta_v = \int_0^{\ell} (Wx + M)x \cdot \frac{dx}{EI}$$

∴ $W = 0$ {fictitious load}

$$\delta_{Lv} = \frac{M}{EI} \int_0^{\ell} x \cdot ds = \frac{M\ell^2}{2EI}$$

For member BC

$$M_x = W + M$$

$$\frac{\partial M_x}{\partial W} = \ell$$

$$\delta_v = \int_0^h (W\ell + M)\ell \frac{dx}{EI}$$

$$\delta_v = \frac{M\ell}{EI} \int_0^h dx = \frac{M\ell h}{EI}$$

∴ $W = 0$

$$\delta = \frac{M\ell}{EI} \left(h + \frac{\ell}{2} \right)$$

$$(\delta_v)_A = \frac{\mu\ell}{EI} \left[h + \frac{\ell}{2} \right]$$

07. Ans: (d)

Sol: Strain energy (u) of Bar AB = $\frac{F^2 \ell}{2AE}$

Where F = Axial force in the Bar

$$F_{AB} = 0$$

$$\therefore u_{AB} = 0$$

08. Ans: (b)

Sol:

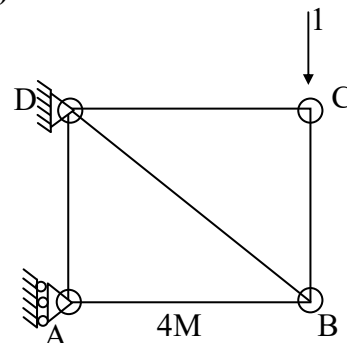



Apply unit load in the vertical direction at 'C'. Due to this unit load $F_{CB} = 1$
 Change in length of member BC due temperature change = $\alpha t l$
 $= 10 \times 10^{-6} \times 4000 \times 25 = 1\text{mm}$
 $\therefore \delta_{VC} = \Sigma k \times \delta' = 1 \times 1 = 1\text{mm}$

09. Ans: (a)

Sol:

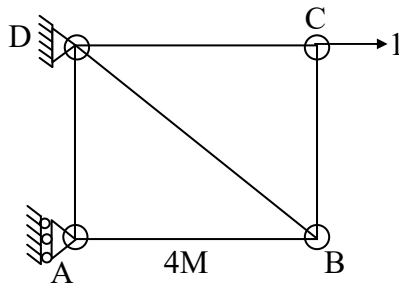

Apply unit horizontal load at 'C'.
 Due to this the force in the member BC zero.
 \therefore Horizontal deflection @ C = $\Sigma k' \delta' = 0$

10. Ans: (d)

Sol:

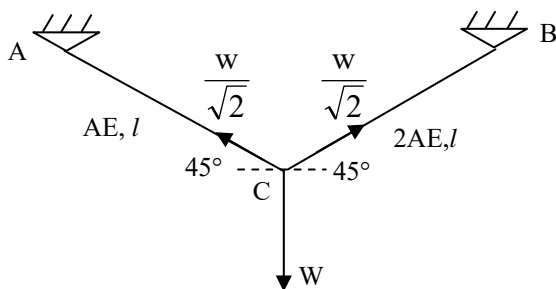

Apply unit vertical load at 'C'. to get the values of k.

Members	Force P	k	$\frac{l}{AE}$	$\frac{Pk}{AE}$
AC	$-\frac{W}{\sqrt{2}}$	$-\frac{1}{\sqrt{2}}$	$\frac{l}{AE}$	$\frac{Wl}{2AE}$
AB	$-\frac{W}{\sqrt{2}}$	$\frac{1}{\sqrt{2}}$	$\frac{l}{2AE}$	$\frac{Wl}{4AE}$

$$(\delta_v)_c = \sum \frac{Pk}{AE} = \frac{Wl}{2AE} + \frac{Wl}{4AE} = \frac{3Wl}{4AE}$$

11. Ans: (d)

Sol: Apply unit horizontal load at 'C'. to get the values of k'

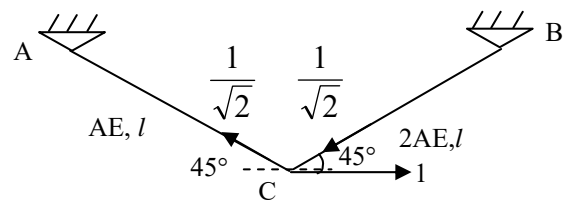

Members	P	k'	$\frac{l}{AE}$	$\frac{Pk'l}{AE}$
AC	$-\frac{W}{\sqrt{2}}$	$-\frac{1}{\sqrt{2}}$	$\frac{l}{AE}$	$\frac{Wl}{2AE}$
AB	$-\frac{W}{\sqrt{2}}$	$\frac{1}{\sqrt{2}}$	$\frac{l}{2AE}$	$-\frac{Wl}{4AE}$

$$(\delta_H)_C = \sum \frac{Pk'l}{AE} = \frac{Wl}{2AE} - \frac{Wl}{4AE} = \frac{Wl}{4AE}$$

12. Ans: 1.5×10^{-3}

Sol: As the structure is determinate extra forces will not be generated due to lack of fit.

$$\tan \theta = \left(\frac{6}{4 \times 10^3} \right) \text{ Inclusion of member BC}$$

is mainly due to 6 mm extension in BD

$$\theta = 1.5 \times 10^{-3} \text{ Radians.}$$



13. Ans: (c)

Sol:

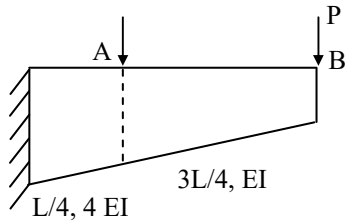

Maxwell's law of Reciprocal deflections:

$$\delta_{ij} = \delta_{ji} \quad \text{where}$$

δ_{ij} = deflection @ 'i' due to unit load at 'j'

δ_{ji} = deflection @ j due to unit load at i

Further Maxwell's law is valid for both prismatic and non prismatic beams.

Maxwell's theorem independent of EI.

Hence option 'C'.

14. Ans: (c)

Sol:

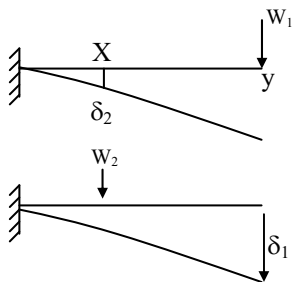

Using Betti's Theorem:

Virtual work done by

$W_1 =$ virtual work done by W_2

$$\therefore W_2 \delta_2 = W_1 \delta_1$$

$$\Rightarrow \frac{\delta_1}{\delta_2} = \frac{W_2}{W_1}$$

Chapter- 6
Moment Distribution Method

Class Room Practice Solutions

01. Ans: (a)

Sol:

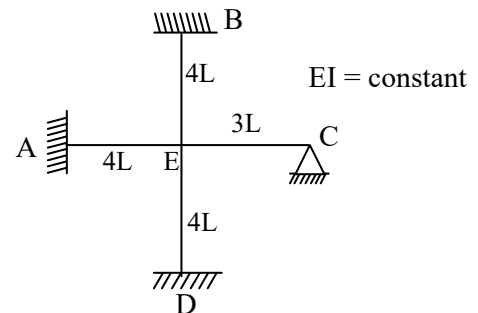

$$(D.F)_{BE} = \frac{\frac{I}{4L}}{\frac{I}{4L} + \frac{I}{4L} + \frac{I}{4L} + \frac{3}{4} \times \frac{I}{3L}} = \frac{1}{4}$$

02. Ans: (c)

Sol:

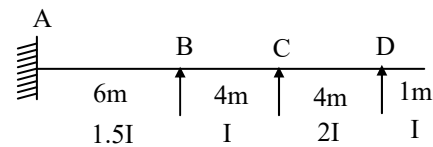

Joint	Member	Relative stiffness 'k'	Distribution factor D.F= k / Σk
B	BA	1.5I/6	0.5
	BC	I/4	0.5
C	CB	$\frac{I}{4}$	0.4
	CD	$\frac{3}{4} \left(\frac{2I}{4} \right)$	0.6



Note: Over hang present beyond 'D' does not give fixity. Hence 'D' will act like simple support. 'B' and 'C' have other supports beyond them. Hence they act like fixed supports to calculate stiffness

03. Ans: (a)

Sol:

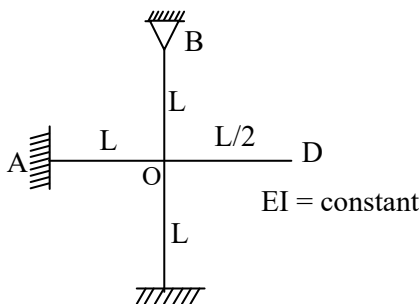

Rotational stiffness of a joint is the sum of stiffness of all members meeting at that joint

$$\therefore K_O = K_{OA} + K_{OB} + K_{OC} + K_{OD}$$

$$\Rightarrow \frac{4EI}{L} + \frac{3EI}{L} + \frac{4EI}{L} + 0 = \frac{11EI}{L}$$

04. Ans: (b)

Sol:

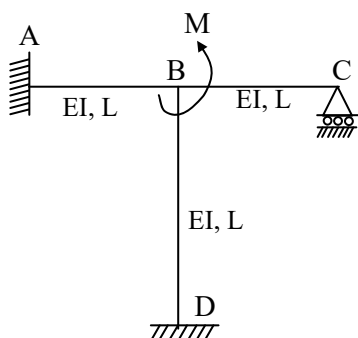

Rotational stiffness of joint 'B'

$$= \frac{11EI}{L}$$

$$\Rightarrow \frac{M}{\theta} = \frac{11EI}{L}, \theta = \frac{ML}{11EI}$$

θ = Rotation of joint 'B'.

05. Ans: (b)

Sol:

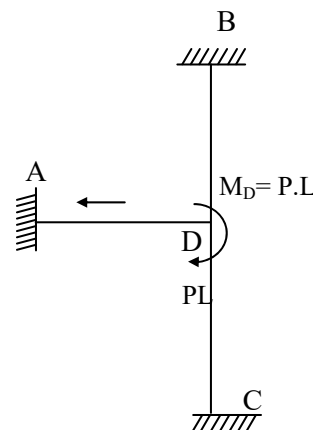
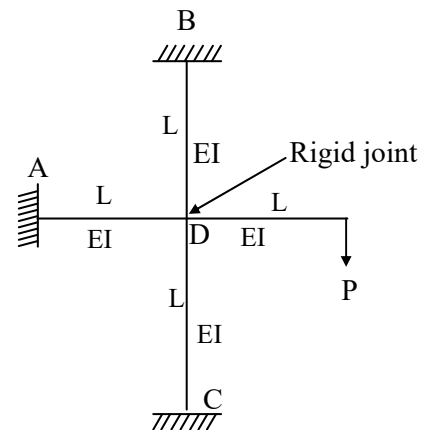

Member	D.F
DB	$\frac{1}{3}$
DA	$\frac{1}{3}$
DC	$\frac{1}{3}$

Moment at 'D' transferred from over hang,

$$M_D = P.L$$



Distribution factors are $\frac{1}{3}$, $\frac{1}{3}$, $\frac{1}{3}$ to DA, DB, DC respectively.

$$\therefore M_{DA} = \frac{PL}{3}$$

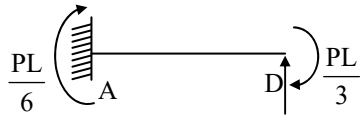

$$\Rightarrow M_A = \frac{1}{2} \times \frac{PL}{3} = \frac{PL}{6}$$

(Far end 'A' is fixed, hence the carry over moment is half of that of moment of near end 'D' of beam 'AD')

06. Ans: (d)

Sol:

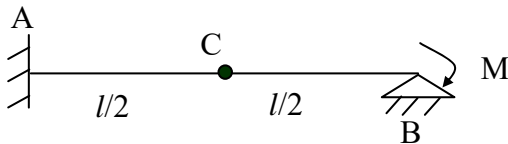

Consider free body diagram of 'BC'

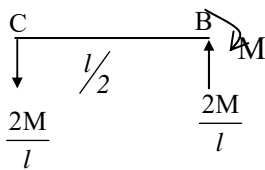

Consider free body diagram of 'AC'

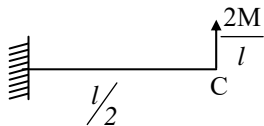

$$\text{Moment at 'A'} = \frac{2M}{l} \times \frac{l}{2} = M$$

07. Ans: (c)

Sol:

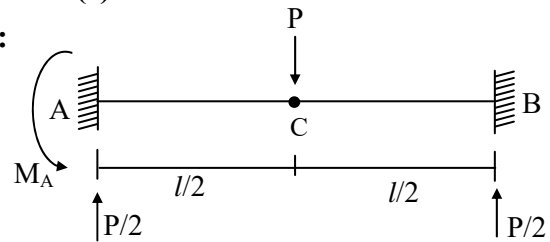

Load is acting at center of the beam.

$$\therefore R_A = R_B = \frac{P}{2} (\uparrow)$$

As center 'C' has an internal moment hinge

$$\sum M_C = 0$$

$$\therefore M_A = R_B \times \frac{L}{2}$$

$$= \frac{p}{2} \times \frac{L}{2}$$

$$\therefore M_A = \frac{pl}{4} \text{ (anticlockwise)}$$

08. Ans: (d)

Sol: Carry over factor

$$C_{AB} = \frac{\text{Moment developed at far end}}{\text{Moment applied at near end}}$$

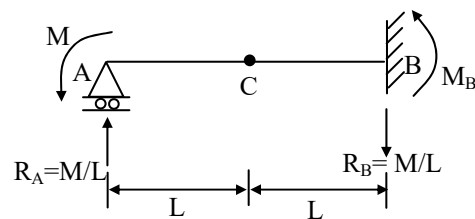

Let us apply moment 'M' at A

For R_A ; take moment @ C = 0



$$\therefore \sum M_c = 0 \quad \therefore R_A \times L = M$$

$$R_A = M/L \text{ (upward)}$$

$$\& R_B = \frac{M}{L} \text{ (downward)}$$

Again $\sum M_c = 0$ from right side

$$\therefore M_B = R_B \times L$$

$$M_B = \frac{M}{L} \times L$$

$$\therefore M_B = M$$

$$\text{Carry over factor} = \frac{\text{Moment at B}}{\text{Moment at A}} = \frac{M}{M} = 1$$

09. Ans: (c)

Sol:

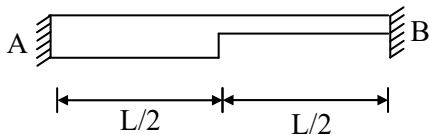

For prismatic beam with uniform EI,

$$\text{The carry over factor} = \frac{1}{2}$$

Beam towards 'A' is more stiff (has more EI)

Beam towards 'B' is less stiff (has less EI)

\therefore Carry over factor to 'B' is less than half

10. Ans: (a)

Sol:

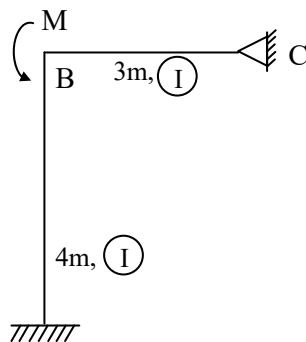

	k	D.F
BA	$\frac{1}{4}$	$\frac{1}{2}$
BC	$\frac{3}{4} \frac{I}{3}$	$\frac{1}{2}$

$$D.F_{BA} = \frac{1}{2}$$

$$D.F_{BC} = \frac{1}{2}$$

Hence applied joint moment 'M' gets equally distributed to members 'BA' and 'BC'.

$$\therefore M_{BA} = M/2, M_{BC} = M/2$$

11. Ans: (a)

Sol:

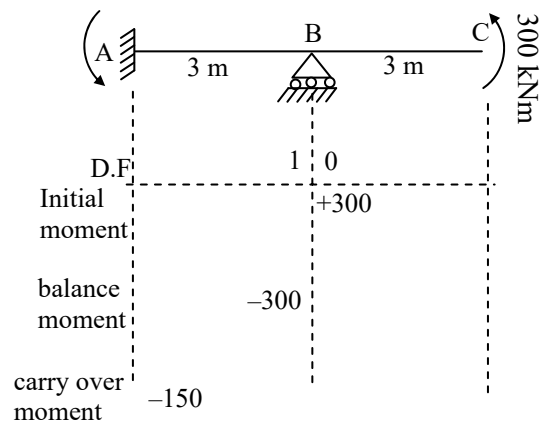

\therefore Correct answer is 150 kN.m hogging.

Shortcut:

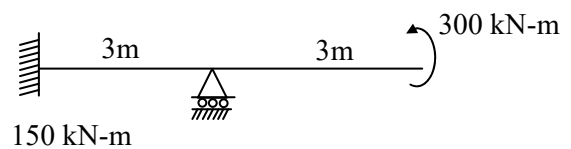

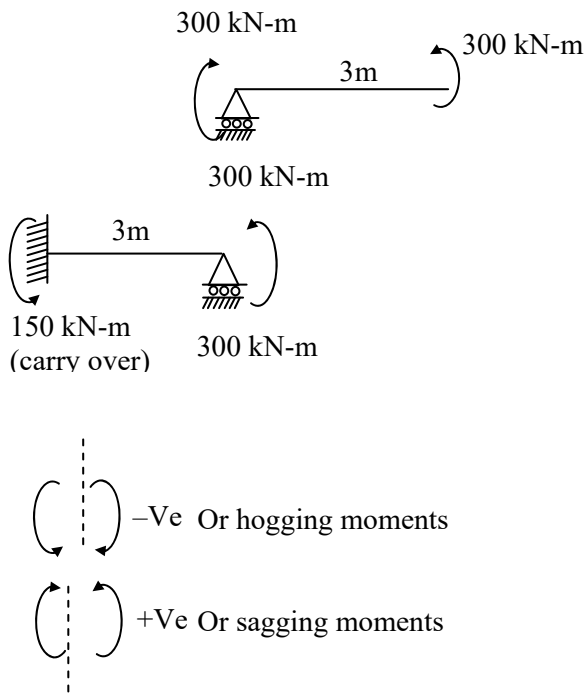

12. Ans: (b)

Sol:

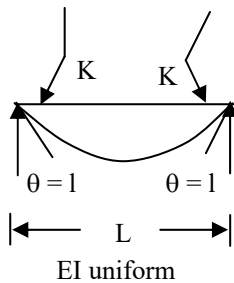

We know that moment required to produce a unit rotation is called stiffness.

∴ Slope $\theta = 1$ at both ends

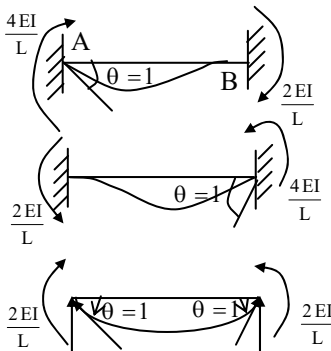

Initially for $\theta=1$ (clockwise) At A, keeping 'B' fixed.

$$M_{AB} = \frac{4EI}{L} \text{ (Clockwise)}$$

$$M_{BA} = \frac{2EI}{L} \text{ (Clockwise)}$$

Then allow $\theta=1$ (anticlockwise) at B, keeping 'A' as fixed.

Now,

$$M_{BA} = \frac{4EI}{L} \text{ (anticlockwise)}$$

$$M_{AB} = \frac{2EI}{L} \text{ (anti clockwise)}$$

If unit rotation at both ends, as shown

$$\begin{aligned} M_{AB} &= \frac{4EI}{L} - \frac{2EI}{L} \\ &= \frac{2EI}{L} \text{ (Clockwise)} \end{aligned}$$

$$\begin{aligned} M_{BA} &= \frac{4EI}{L} - \frac{2EI}{L} \\ &= \frac{2EI}{L} \text{ (Anti clockwise)} \end{aligned}$$

$$\text{Hence, } K = \frac{2EI}{L} = M$$



13. Ans: (c)

Sol:

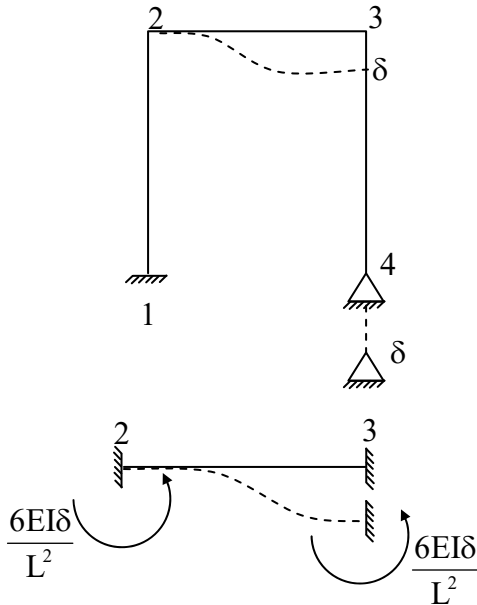

$$M_{23} = \frac{6EI\delta}{L^2}$$

$$= \frac{6EI\delta}{4^2}$$

$$= \frac{6EI\delta}{16}$$

14. Ans: (b)

Sol:

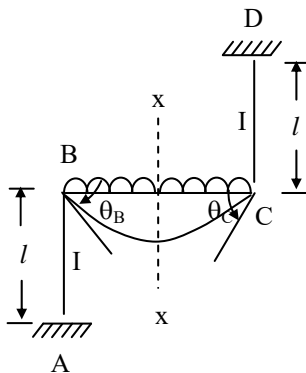

Consider the section passing through the middle of the beam (x-x)

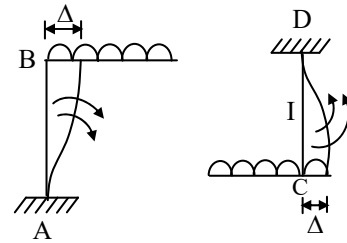

$\therefore \Delta$ is present.

From the above diagram, it is seen that in the member BC rotation is clock wise at B and anticlockwise at C.

$\therefore \theta_B = -\theta_C$

15. Ans : (b)

Sol:

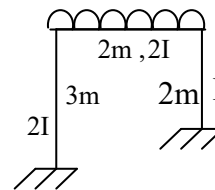

Moment required for sway of right column

$$= \frac{6EI\delta}{2^2} = \frac{6EI\delta}{4}$$

$$= \frac{3}{2} EI\delta = 1.5EI\delta$$

Moment required for sway of left column

$$= \frac{6(2EI)\delta}{3^2}$$

$$= \frac{4}{3} EI\delta = 1.33EI\delta$$



As the left column requires less moment for sway compared to right column, the resistance of left column is less against sway.

∴ Frame will sway towards left

16. Ans: (b)

Sol:

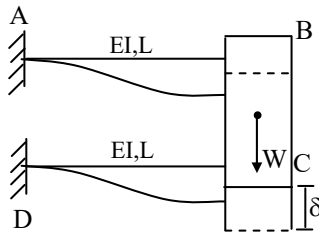

Hint: As bar 'BC' is rigid it acts like sinking fixed support.

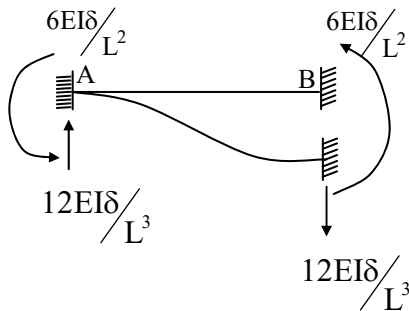

Free body diagram of 'AB'

As seen from above F.B.D. the ↓ reaction developed at B is $12 EI\delta / L^3$.

Similarly from F.B.D of 'CD' the ↓ reaction developed at 'C' is $12 EI\delta / L^3$.

∴ from vertical equilibrium condition,

$$\text{Wt. of rigid block } W = 12EI\delta / L^3 + 12EI\delta / L^3 \\ = 24EI\delta / L^3$$

$$\Rightarrow \text{down ward deflection } \delta = WL^3 / 24EI$$

17. Ans: (a)

Sol:

	A	B	C
D.F	$1/2$	$1/2$	
Initial moments	$-\frac{wl}{8}$	$+\frac{wl}{8}$	$+\frac{wl}{8}$
Balance moments	$+\frac{wl}{8}$		$-\frac{wl}{8}$
C.O	0	$+\frac{wl}{16}$	$-\frac{wl}{16}$
Final Moments	0	$+\frac{3wl}{16}$	$-\frac{3wl}{16}$

$$\text{Free moment at centre of AB} = \frac{WL}{4}$$

Using the Moment distribution method

$$\text{Moment at support B, } M_B = \frac{3wl}{16}$$

$$\text{The ratio of support moment at 'B' and free moment of AB} = \frac{3WL}{16} \times \frac{4}{WL} = 0.75$$

18. Ans: (a)

Sol:

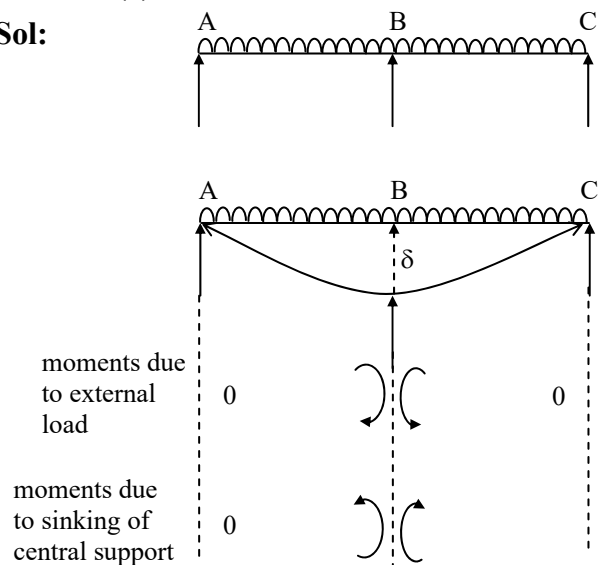



The directions of moments at central support due to external load and sinking of central support are shown.

As seen above, the net central support moment (negative moment) reduces.

From the fundamentals of redistribution of moments, if negative moment at central support decreases, the positive (sagging) moment at midspan increases.

19. Ans: 1

Sol:

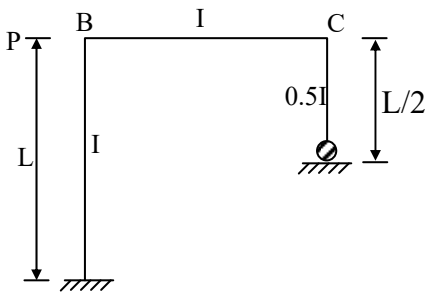

$$\text{Sway moment, } M_{BA} \propto \frac{6EI\delta}{L^2}$$

$$\text{Sway moment, } M_{CD} \propto \frac{3E(0.5I)\delta}{(0.5L)^2}$$

$$= \frac{6EI\delta}{L^2}$$

$$\therefore \frac{M_{BA}}{M_{CD}} = 1$$

20. Ans: 4

Sol:

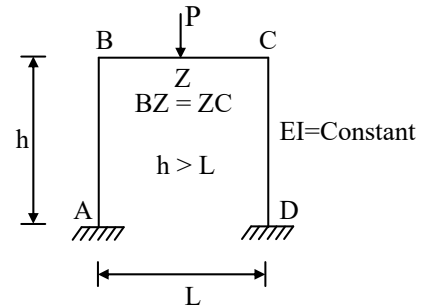

Free body diagrams of beam and columns are shown below.

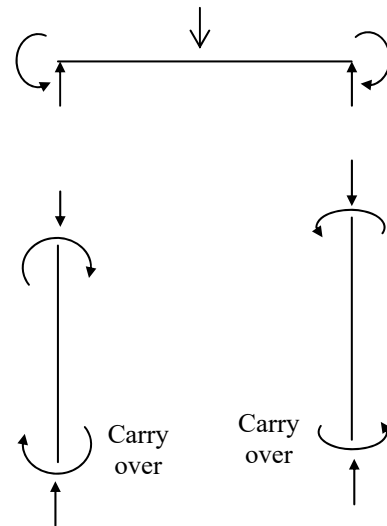

The B.M.D of the frame is shown below.

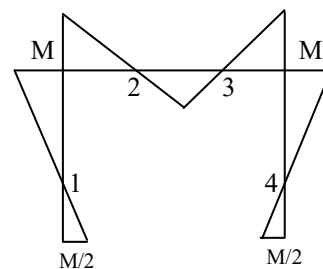

At the locations 1, 2, 3 and 4, the bending moment is changing sign. Hence, four points of contra flexure.



21. Ans: 20

Sol:

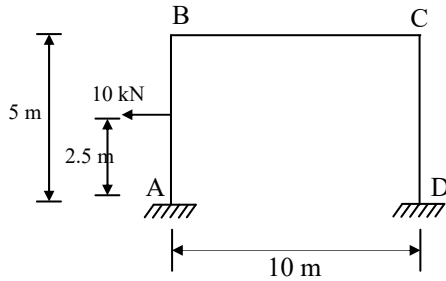

For column AB, $\Sigma M_B = 0$

$$5H_A = 15 + 10 + 10 \times 2.5$$

$$\Rightarrow H_A = 10 \text{ kN} \rightarrow$$

Applying $\Sigma H = 0$

$$H_A + H_D = 10$$

$$10 + H_D = 10$$

$$\Rightarrow H_D = 0$$

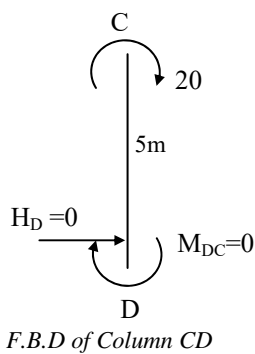
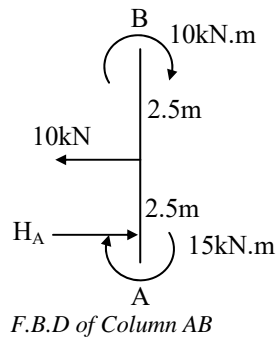

$$H_D = \frac{M_{CD} + M_{DC}}{5} = 0$$

$$\frac{20 + M_{DC}}{5} = 0$$

$$\Rightarrow M_{DC} = -20 \text{ kN-m}$$

22. Refer GATE solutions Book.

23. Refer GATE solutions Book.

Chapter- 7 Slope Deflection Method

Class Room Practice Solutions

01. Ans: (a)

Sol: In slope deflection method deformation due to axial force and shear force are neglected. Deformations due to flexure only are considered.

02. Ans: (c)

Sol: No. of unknown joint displacements is the most appropriate option. Option (b) is ambiguous as nothing is spelt about axial deformations.

03. Ans: (c)

Sol: The number of equilibrium equations is = number of unknown joint displacements.





For the above beam unknown displacement is the rotation at central support only.

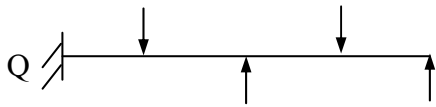

For the above beam unknown displacements are the rotations at central support and right end support.

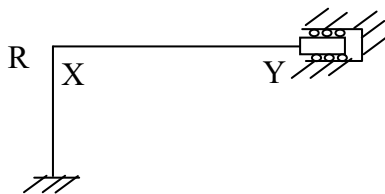

For the above frame unknown displacements are the rotation at rigid joint X and sway deflection at right support Y.

04. Ans: (a)

Sol:
$$M_{BA} = \frac{2EI}{L} \left[2\theta_B + \theta_A - \frac{3\delta}{L} \right]$$

Note:

Clock wise rotations are taken as +Ve.

Anti clock wise rotations are -Ve.

δ = relative sinking of right support with respect to left support. In the standard equation right support is assumed to sink more than left support and δ is taken as +Ve.

In the given problem θ_A is clock wise hence taken as positive. θ_B is anti clock wise hence taken as negative. Further right support sinks less than that of left support.

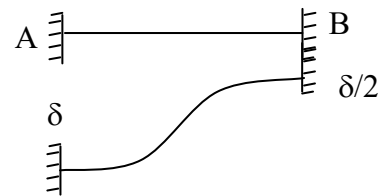
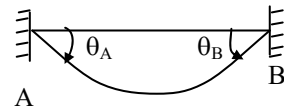

$$M_{BA} = \frac{2EI}{L} \left[-2 \cdot \left(\frac{\theta}{2} \right) + \theta - \frac{3}{L} \left(\frac{\delta}{2} - \delta \right) \right]$$

$$= \frac{3EI\delta}{L^2}$$

05. Ans: (a)

Sol:

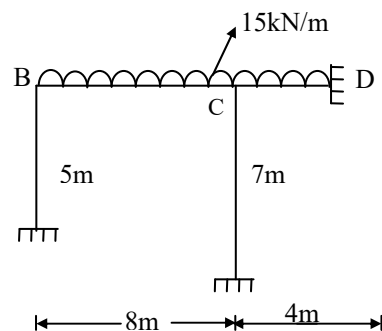

Fixed end moment
$$\bar{M}_{BC} = \frac{-WL^2}{12}$$

$$= -\frac{15 \times 8^2}{12} = -80 \text{ kN.m}$$

$$M_{BC} = \frac{2EI}{L} \left[2\theta_B + \theta_C - \frac{3\delta}{L} \right] + \bar{M}_{BC}$$

$$M_{BC} = \frac{2EI}{8} [2\theta_B + \theta_C - 0] - 80$$

$$= 0.25EI(2\theta_B + \theta_C) - 80$$



06. Ans: (c)

Sol:

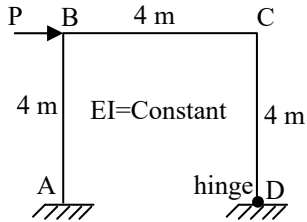

Free body diagrams of columns shown below.

The joint moments are assumed clock wise

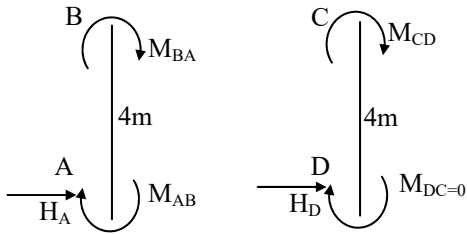

For horizontal equilibrium $\sum H = 0$

$$H_A + H_D + P = 0$$

$$H_A = \frac{M_{AB} + M_{BA}}{4}$$

$$H_D = \frac{M_{CD} + M_{DC}}{4} = \frac{M_{CD} + 0}{4} = \frac{M_{CD}}{4}$$

$$\frac{M_{BA} + M_{AB}}{4} + \frac{M_{CD}}{4} + P = 0$$

07. Ans: (b)

Sol:

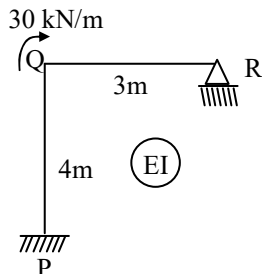

At joint 'Q' relative stiffness

$$= \frac{M}{\theta} = \frac{30}{\theta} = \frac{3EI}{3} + \frac{4EI}{4} = 2EI$$

$$\theta_Q = \frac{15}{EI}$$

08. Ans (a)

Sol: Slope at 'R'

$$M_R = 0 = \frac{2EI}{3}(2\theta_R + \theta_Q)$$

$$\frac{\theta_Q}{2} = -\theta_R \Rightarrow \theta_R = \frac{-\theta_Q}{2} = \frac{-7.5}{EI}$$

(Sign neglected)

Chapter- 8 Plastic Theory

Class Room Practice Solutions

01. Ans: (d)

Sol: Ductile materials like mild steel are used for design using plastic theory. For ductile materials plastic deformation before Fracture is much larger than elastic deformation.

02. Ans: (c)

Sol: Shape factor is the ratio of plastic moment and yield (elastic) moment.

$$S = \frac{M_p}{M_e} = \frac{f_y \cdot Z_p}{f_y \cdot Z} = \frac{Z_p}{Z}$$



We know that section modulus represents the strength of a section both in plastic and elastic theory.

As $Z_P > Z_Y$ for all sections, shape factor indicates the increase of strengths of a section due to plastic action over elastic strength.

Hence statements 1 and 2 are correct.

Shape factor is more if area near neutral axis is more (bulk area).

For example :

- i) Consider a square section and circular section of same area.

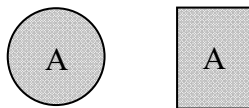

$$S_{\text{circle}} = 1.7 \quad S_{\text{square}} = 1.5$$

- ii) Refer solution of Problem 3: for I section along Y axis area is more near neutral axis compared to area near X axis. Hence shape factor $S_{YY} > S_{XX}$
∴ statement 3 is wrong.

03. Ans: (d)

Sol:

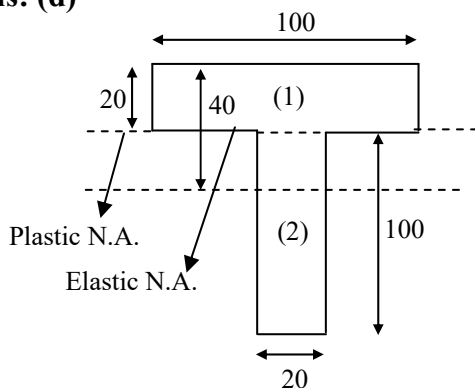

Elastic N.A. distance from top of flange

$$y_e = \frac{A_1 Y_1 + A_2 Y_2}{A_1 + A_2}$$

$$y_e = \frac{100 \times 20 \times 10 + 100 \times 20 \times 70}{2000 + 2000} = 40\text{mm}$$

Plastic N.A. from top of flange;

Plastic N.A. divides the section in to two equal areas.

Total area of the section = 4000mm^2

Half of area = 2000mm^2

As the flange area is also equal to 2000mm^2 , the plastic neutral axis lies at the junction of flange and web.

∴ Plastic neutral axis distances from top

$$y_p = 20\text{mm}$$

Distance between plastic N.A.

and Elastic N.A. = $40 - 20 = 20\text{ mm}$

Note: Better use calculations in cm to save time

04. Ans: (a)

05. Ans: (c)

Sol: Plastic moment $M_P = f_y \times z_p$

Given,

$$M_P = 120\text{ kN.m}$$

$$M_P = f_y \times 5 \times 10^{-4}$$

∴ Yield stress

$$f_y = \frac{120 \times 10^6}{5 \times 10^{-4}} = 24 \times 10^{10}\text{ N/m}^2$$

$$= 240\text{ N/mm}^2$$



06. Ans: (a)

Sol:

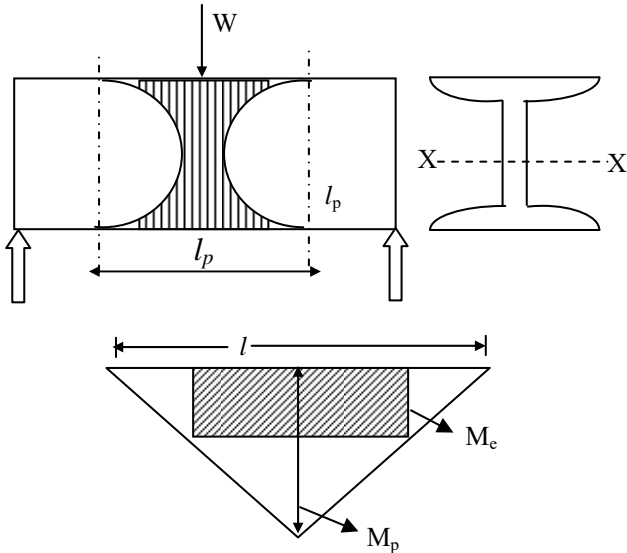

From similar triangles,

$$\frac{l_p}{(M_p - M_e)} = \frac{l}{M_p}$$

$$l_p = \frac{l(M_p - M_e)}{M_p}$$

$$l_p = l \left[1 - \frac{1}{S} \right]$$

(Shape factor of I section ≈ 1.12)

$$= l \left[1 - \frac{1}{1.12} \right]$$

$$\therefore l_p \approx \frac{l}{8}$$

07. Ans: (c)

Sol:

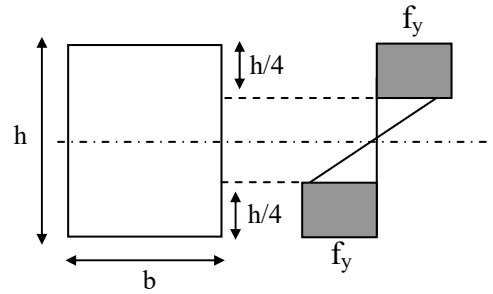

M_{ep} = M. R of elasto plastic section

= M.R. of elastic part + M.R. of Plastic part

$$= f_y \cdot Z + f_y \cdot Z_p$$

$$Z_{\text{elastic part}} = \frac{b}{6} \cdot \left(\frac{h}{2} \right)^2 = \frac{bh^2}{24}$$

$$Z_{\text{plastic part}} = 2 \left[b \left(\frac{h}{4} \right) \left(\frac{h}{4} + \frac{h}{8} \right) \right] = \frac{3bh^2}{16}$$

$$\therefore M_{ep} = f_y \cdot Z + f_y \cdot Z_p$$

$$= f_y \left[\frac{bh^2}{24} + \frac{3bh^2}{16} \right] = \frac{11}{48} f_y \cdot bh^2$$

Shortcut :

- M.R of fully plastic section = $f \cdot bh^2/4$
- M.R of fully elastic section = $f \cdot bh^2/6$
- M.R of partly plastified section lies between the above two values.
($f \cdot bh^2/6$) < M_{ep} < $f \cdot bh^2/4$
- The denominator of the above value will be between 4 and 6. Hence by elimination technique option c.



08. Ans: (d)

Sol: Load factor (Q)

$$= \frac{\text{Factor of safety in elastic theory} \times \text{shape factor}}{1 + \text{additional \% of stress allowed for wind}}$$

$$= \frac{1.5 \times 1.12}{1 + 0.2} = 1.4$$

09. Ans: (c)

Sol:

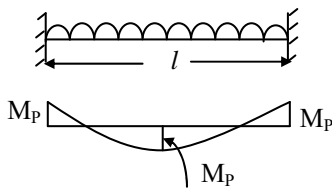

$$\frac{W_c L}{8} = 2M_p \Rightarrow W_c = 16 \frac{M_p}{L} \quad \dots\dots (1)$$

At the elastic limit, the centre moment is one-half of the end moment.

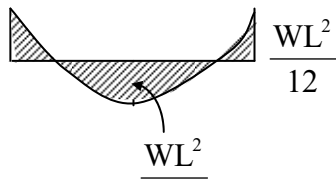

$$\frac{W_c L}{8} = M_e + \frac{M_e}{2}$$

$$\Rightarrow W_c = \frac{12M_e}{L} \quad \dots\dots (2)$$

From eqs. (1) & (2)

$$\frac{W_c}{W_c} = \frac{\frac{16M_p}{L}}{\frac{12M_e}{L}} = \frac{4M_p}{3M_e} = \frac{4}{3} \times \text{shape factor}$$

$$= \frac{4}{3} \times \frac{3}{2} = 2$$

(For rectangular section S = 1.5)

Deformation is just observed means the beam is subjected to elastic failure with yield load ($W_e=10\text{kN/m}$)

$$\therefore \text{Collapse load} = 2 \times 10 = 20\text{kN/m}$$

10. Ans : (b)

Sol:

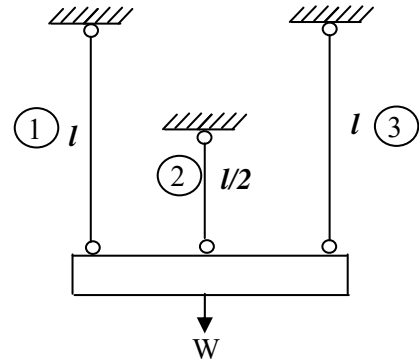

The given frame is symmetrical both in loading and configuration. The rigid block of weight W will have uniform deflection.

All the three wires will have same elongation. Strain = change in length/original length

As central wire has half length compared to end wires, the strain of central wire is two times that of end wires. Hence the central wire will reach the yield stress 'fy' initially.

The end wires will have half the strain of that of middle wire. Hence they reach stress of $0.5f_y$ when the middle wire yields.

The load corresponding to yielding of one of the wires

$$W_e = f_y \cdot A + 2(0.5f_y) A = 2 f_y \cdot A$$

At plastic collapse the end wires will also reach yield stress f_y .

When the end wires are yielding, the stress in the middle wire remains constant (f_y).



∴ collapse load = $3f_y \cdot A$

∴ ratio of collapse load and yield load = 3:2

11. Ans: (a)

Sol: In all theories, viz. elastic theory, plastic theory and limit state theory, Bernouli's assumption is valid according to which "Plane transverse sections which are plane and normal to the longitudinal axis before bending remain plane and normal after bending".

It means

Strain variation
is linear as shown
aside

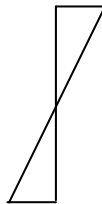

12. Ans: (a)

Sol:

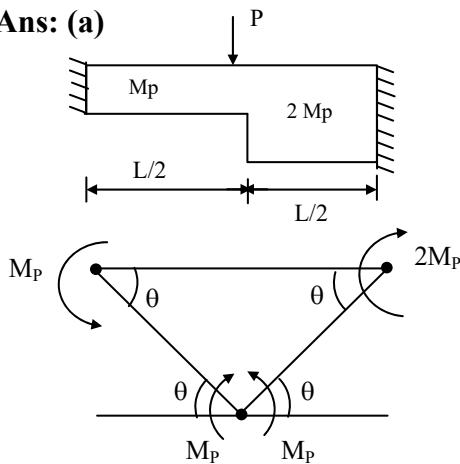

External workdone = Internal workdone

$$5 M_p \theta = p \times L/2 \times \theta$$

$$\frac{10M_p}{L} = p$$

$$\text{Collapse load} = \frac{10M_p}{L}$$

13. Ans: (d)

Sol:

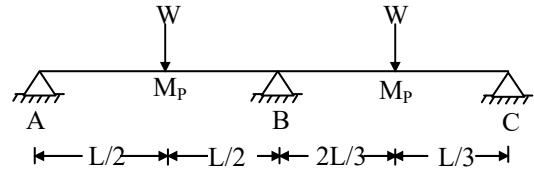

The given continuous beam will have two independent mechanisms. Both will behave like propped cantilevers. Beam AB has central point load which has more B.M. compared to BC which has eccentric point load. Hence mechanism AB is sufficient to know collapse load in objective papers.

Mechanism AB:

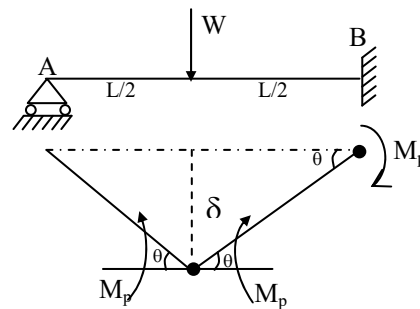

$$W_i = 3M_p \theta$$

$$W_e = W \delta = W \frac{L}{2} \cdot \theta$$

$$W_e = W_i$$

$$\Rightarrow \text{Collapse load } W_C = \frac{6M_p}{L}$$



14. Ans: (c)

Sol:

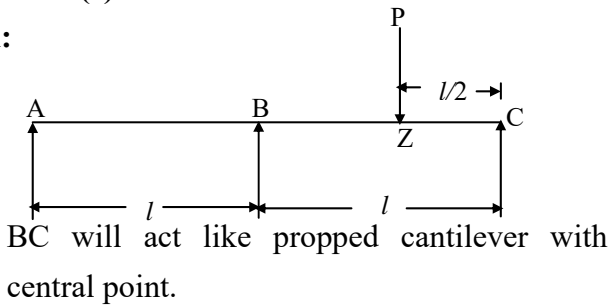

$$\text{Collapse load} = P = \frac{6M_p}{L}$$

15. Ans: (b)

Sol:

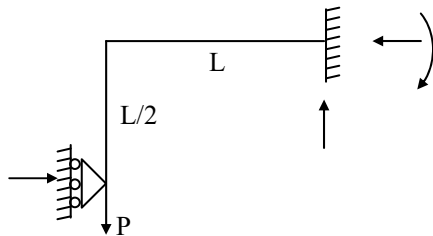

Sway mechanism only possible.

$$D_S = 4 - 3 = 1$$

Number of plastic hinges for collapse = 1 + 1 = 2

Plastic hinge and moment towards beam side only since no rotation towards vertical column side.

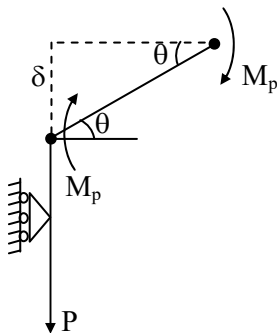

$$W_i = 2M_p\theta ; W_e = P.\delta = P.L.\theta$$

$$W_e = W_i$$

$$\Rightarrow P = \frac{2M_p}{L}$$

16. Ans: (c)

Sol:

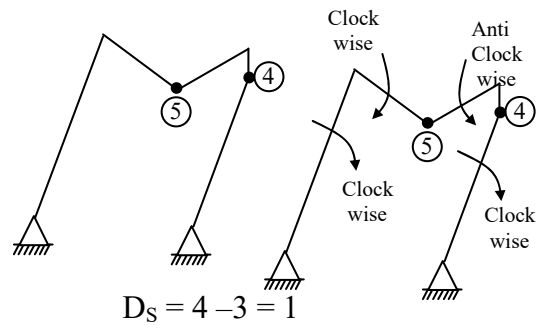
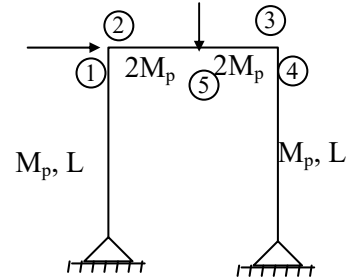

\therefore Two plastic hinges will form at failure for combined mechanism. One plastic hinge will form under point load (5) on the beam. The second plastic hinge will form at (4) on the column side of Lee ward side node of frame as column side has M_p which is less than $2M_p$ of beam.

Reason for not having plastic hinge on windward side: As seen in the combined mechanism, the column and beam have rotations in the same direction (clock wise) and hence the initial included angle will not change.

Reason for having plastic hinge on Lee ward side: As seen in the combined mechanism, the column and beam have rotations in the



opposite (column clock wise and beam anti clock wise) and hence the initial included angle changes leading to plastic hinge on weaker side.

17. Ans: (b)

Sol:

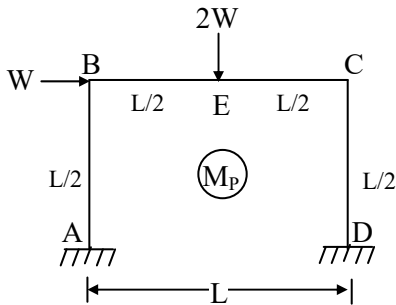

(i) Beam Mechanism BC:

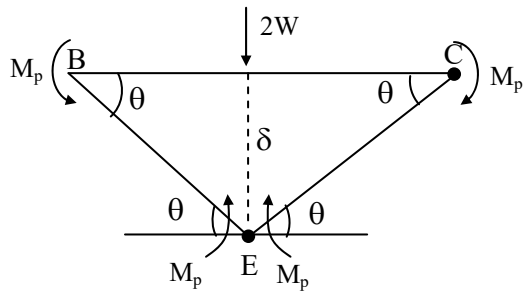

$$W_e = 2W \cdot \delta = 2W \cdot \left(\frac{L}{2}\right) \cdot \theta$$

$$W_i = 4M_p \cdot \theta$$

$$W_i = W_e$$

$$\Rightarrow W = \frac{4M_p}{L} \quad \dots (i)$$

(ii) Sway Mechanism:

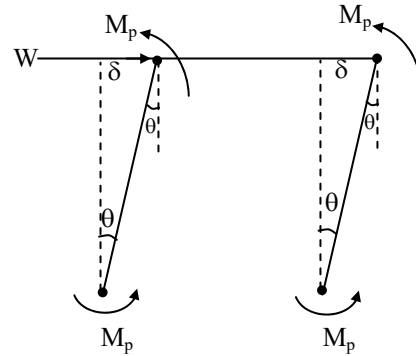

$$W_i = W_e \Rightarrow 4M_p \cdot \theta = W \cdot \delta$$

$$4M_p \cdot \theta = W \theta \times \frac{L}{2}$$

$$\Rightarrow W = \frac{8M_p}{L} \quad \dots (ii)$$

(iii) Combined Mechanism:

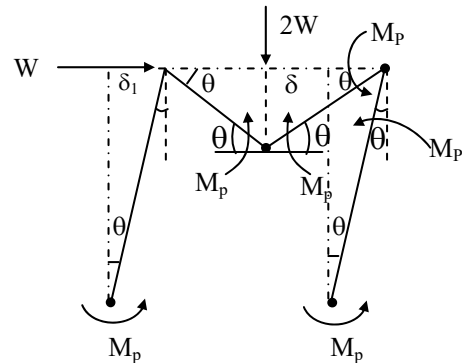

$$W_e = W \cdot \delta_1 + 2W \cdot \delta$$

$$= W \cdot \left(\frac{L}{2}\right) \cdot \theta + 2W \cdot \left(\frac{L}{2}\right) \cdot \theta$$

$$W_i = M_p \cdot \theta + M_p \cdot \theta + M_p \cdot \theta + M_p \cdot \theta + M_p \cdot \theta + M_p \cdot \theta$$

$$= 6M_p \cdot \theta$$

$$W_e = W_i$$

$$\Rightarrow W = \frac{4M_p}{L} \quad \dots (iii)$$



∴ Collapse load is the minimum of above three cases

$$\therefore W_C = \frac{4M_P}{L}$$

Short cut:

Compared to the columns, the beam has double the length and double the load. Hence practically the beam mechanism will govern the collapse.

Chapter- 9
Rolling Loads & Influence Lines

Class Room Practice Solutions

01. Ans: (a)

Sol:

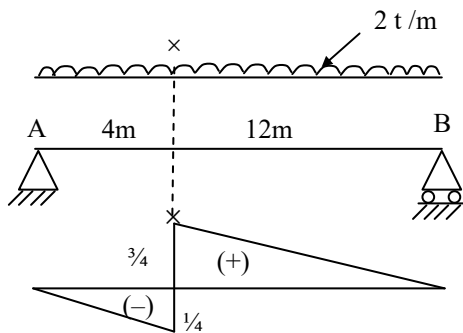

S.F @ = Intensity of u.d.l × area of I.L.D under u.d.l

$$\text{Max } V_x = 2 \left[\frac{1}{2} \times \frac{3}{4} \times 12 - \frac{1}{2} \times \frac{1}{4} \times 4 \right] = 8t$$

02. Ans: (c)

Sol:

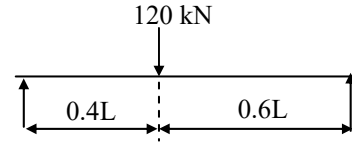

The maximum B.M @ a section occurs if the point load is @ the section.

$$\begin{aligned} \text{Maximum B.M} &= \frac{Wab}{L} = \frac{W \times 0.4L \times 0.6L}{L} \\ &= 0.24 WL \end{aligned}$$

03. Ans: (b)

Sol:

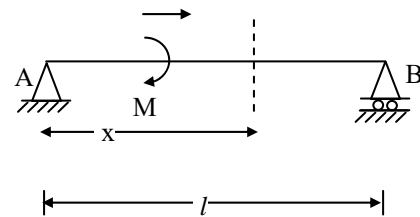

$$R_A = \frac{M}{L} \downarrow \quad R_B = \frac{M}{L}$$

Take moment at the distance 'x' from support A

$$\therefore M_x = M - \frac{M}{L} \cdot x$$

$$\text{When } x = L, \quad M_x = 0$$

$$\text{When } x = 0, \quad M_{\text{max}} = M_x = M$$

04. Ans: (c)



05. Ans: (b)

Sol:

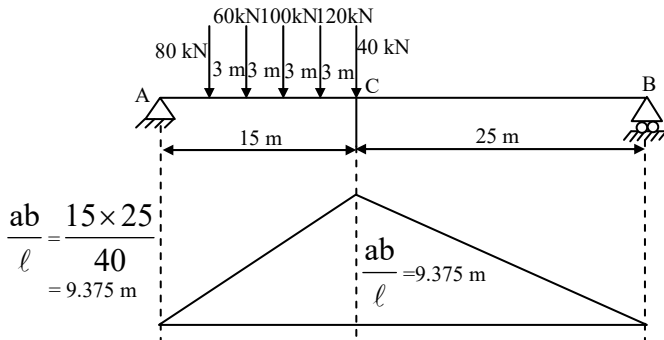

$$\frac{ab}{l} = \frac{15 \times 25}{40} = 9.375 \text{ m}$$

Place 40 kN on section C

$$\text{Avg load on LHS} = \frac{40}{25}$$

$$\frac{80 + 60 + 100 + 120}{15} - \frac{40}{25} = 22.4 \text{ kN}$$

∴ Allow to 40 kN to cross C and place 120 kN on section C

$$\frac{80 + 60 + 100}{15} - \frac{40 + 120}{25} = 9.60 > 0$$

∴ Allow to 120 kN to cross C and place 100 kN on section C

$$\frac{80 + 60}{15} - \frac{40 + 120 + 100}{25} = -1.06 < 0$$

Avg load LHS Avg load on RHS

∴ Place 100 kN on C and other load in their respective position maximum BM at C

06. Refer GATE Solutions Book

07. Refer GATE Solutions Book

08. Refer GATE Solutions Book

09. Ans: (c)

Sol:

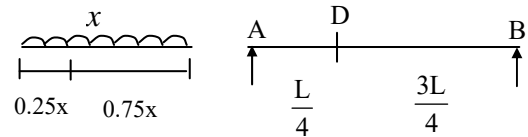

Average load on AD = Avg load on BD

The ratio of AD : DB = 1:3

∴ $\frac{3}{4}$ th of u.d. l has to cross the quarter section 'D'.

10. Ans: (b)

Sol:

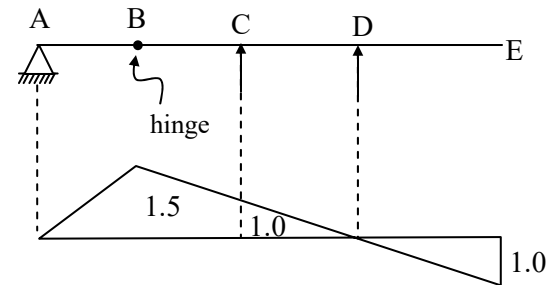

Apply Muller Breslau's principle. To draw I.L.D for support R_C , apply unit vertical displacement at 'C'. To the left of hinge 'B', simple support 'A' exists which cannot offer resistance against rotation but offers resistance against vertical displacement only. Hence hinge 'B' rises linearly as shown. Support 'D' only can rotate. Free end 'E' can have vertical deflection also. Ordinates are proportional to distances as the I.L.D for determinate structures are linear.



11. Ans: (d)

Sol:

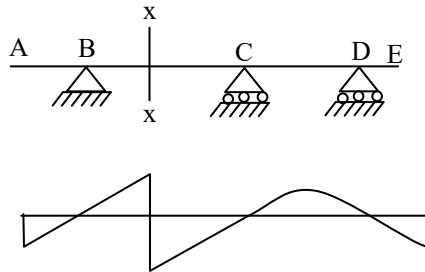

- At x-x the I.L.D has vertical ordinate with change in sign from one side to the other side. It is the character of I.L.D for shear force.
- Using Muller Breslau's principle, release the shear constraint by assuming shear hinge at 'x'. The deflected profile is the I.L.D shown.

12. Ans: (a)

Sol:

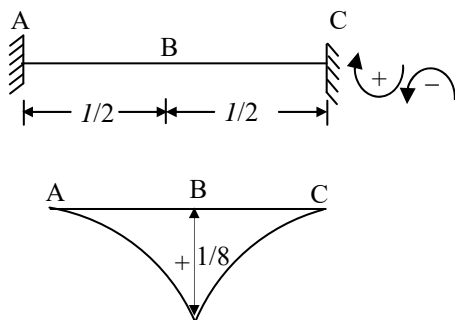

Apply unique rotation at 'B' by assuming a hinge. The deflection profile is the I.L.D for moment at 'B'.

Note: as A and B are fixed $\theta_A = \theta_B = 0$

To calculate ordinate at 'B' assume unit load is applied at 'B'. Due to this the B.M at 'B' = $L / 8$. Further fixed beam being statically indeterminate structure, the I.L.D will be non-linear.

13. Ans: (b)

Sol:

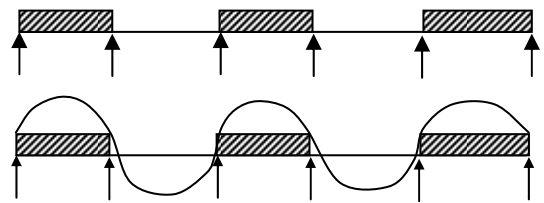

For minimum positive moment at 'x' shown (mid point of second span), no load on second span but u.d.l on alternative spans shall be provided.

- Positive moment at 'x' means sagging in the second span. As minimum positive moment is required, don't place the load on the second span. Further to counter sagging in second span place the u.d.l on alternative spans (1, 3 and 5)
- concept can be easily understood by seeing the deflection profile shown using pattern loading.

Common Data for Questions 14 & 15

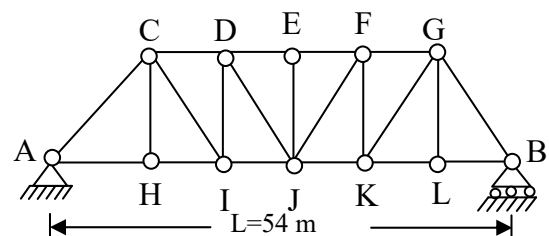



14. Ans: (c)

Sol:



I.L.D for axial force in the member 'CH'

Design force for member CH

= Intensity of u.d.l \times area of I.L.D under u.d.l

$$= (10 + 20) \left(\frac{1}{2} \times 18 \times 1 \right) = 270 \text{ kN (tension)}$$

15. Ans: (d)

Sol: The frame shown is through type truss in which loads will be transferred to the bottom joints. Hence no load is possible at joint 'E'. Hence at 'E' three forces exists of which two are in the same line, hence the third force 'EJ' is zero.

Chapter- 10
Arches & Cables

Class Room Practice Solutions

01. Ans: (a)

Sol:

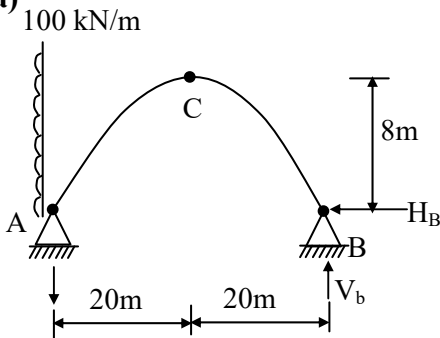

Take moment about A $\Sigma M_A = 0$

$$40 \times V_b = 100 \times 8 \times 8/2$$

$$V_b = 80 \text{ kN}$$

$\Sigma M_C = 0$, from RHS

$$80 \times 20 = H_B \times 8$$

$$H_B = 200 \text{ kN}$$

02. Ans: (b)

Sol:

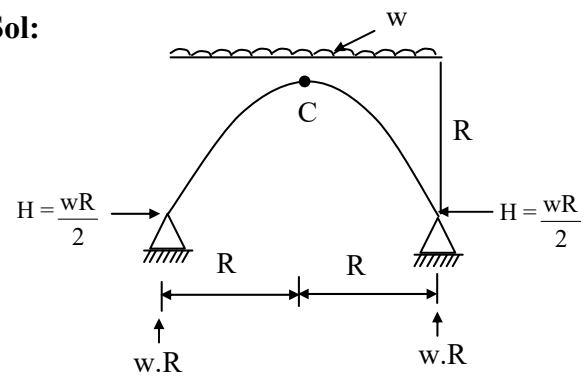

$\Sigma M_c = 0$

$$H.R = wR.R - wR.R/2$$

$$H \times R = wR^2 - \frac{wR^2}{2} = H \times R$$

$$H = \frac{wR}{2}$$

03. Ans: (c)

Sol:

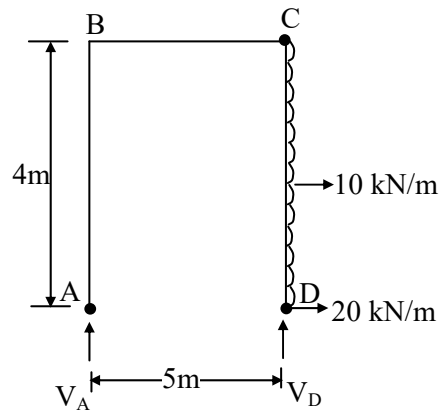



As the support are at same level, the vertical reactions can be worked to similar to that of S.S beam

$$\Sigma M_D = 0 \text{ from left}$$

$$5V_A = 10 \times 4 \times 2 = 80 \text{ kN} \Rightarrow V_A = 16 \text{ kN}$$

04. Ans: (a)

Sol:

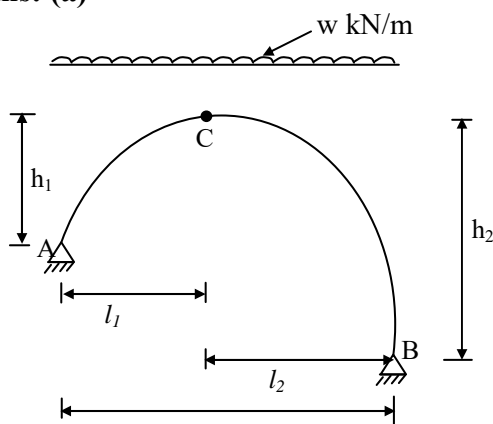

Equation for parabola can be taken as

$$\frac{x^2}{y} = \text{constant}$$

$$\therefore \frac{x}{\sqrt{y}} = \text{constant}$$

$$\therefore \frac{l_1}{\sqrt{h_1}} = \frac{l_2}{\sqrt{h_2}} = \frac{l_1 + l_2}{\sqrt{h_1 + h_2}} = \frac{l}{\sqrt{h_1 + h_2}}$$

$$\therefore l_1 = \frac{l\sqrt{h_1}}{\sqrt{h_1 + h_2}} \quad \text{and} \quad l_2 = \frac{l\sqrt{h_2}}{\sqrt{h_1 + h_2}}$$

Taking moments on left portion about C

$$\therefore V_A \times l_1 - H \times h_1 - w(l_1^2)/2 = 0$$

$$\therefore V_A = \frac{wl_1}{2} + \frac{Hh_1}{l_1} \dots\dots\dots (1)$$

Similarly taking moments on right portion about C,

$$-V_B \times l_2 + H \times h_2 + w(l_2^2)/2 = 0$$

$$\therefore V_B = H \left(\frac{h_2}{l_2} \right) + \frac{wl_2}{2} \dots\dots\dots (2)$$

Apply $\Sigma V = 0$,

$$V_A + V_B = w(l_1 + l_2) = wl$$

Substitute V_A and V_B in above equation

$$\frac{wl_1}{2} + H \left(\frac{h_1}{l_1} \right) + H \left(\frac{h_2}{l_2} \right) + \frac{wl_2}{2} = wl$$

$$H \left(\frac{h_1}{l_1} + \frac{h_2}{l_2} \right) + w \left(\frac{l_1 + l_2}{2} \right) = wl$$

$$H \left(\frac{h_1}{l_1} + \frac{h_2}{l_2} \right) = wl - w \left(\frac{l}{2} \right) = \frac{wl}{2}$$

Substitute l_1 and l_2 in above equation

$$\therefore H \left[\frac{h_1}{\left(\frac{l\sqrt{h_1}}{\sqrt{h_1 + h_2}} \right)} + \frac{h_2}{\left(\frac{l\sqrt{h_2}}{\sqrt{h_1 + h_2}} \right)} \right] = \frac{wl}{2}$$

$$H \left[(\sqrt{h_1} + \sqrt{h_2})\sqrt{h_1} + \sqrt{h_2}(\sqrt{h_1} + \sqrt{h_2}) \right] = \frac{wl^2}{2}$$

$$\therefore H = \frac{wl^2}{2(\sqrt{h_1} + \sqrt{h_2})^2}$$

05. Ans: (b)

Sol:

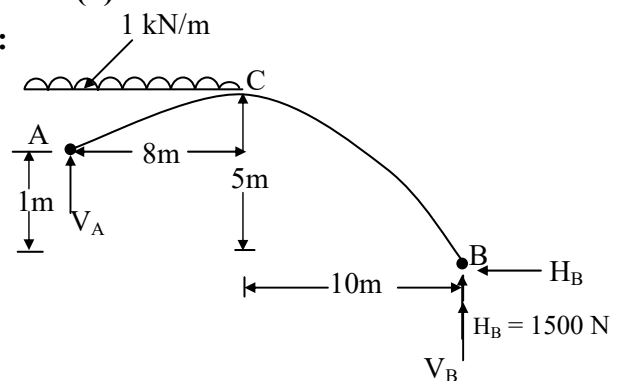



Supports are at different levels $\Sigma M_c = 0$

from right

$$V_b \times 10 = 5 H_b \quad \therefore V_b = 0.5 H_b \quad \dots (1)$$

$\Sigma M_c = 0$, from left.

$$4H_A + 1 \times 8 \times 4 = V_A \times 8$$

$$\therefore V_A = 0.5H_A + 4 \quad \dots (2)$$

$$V_a + V_b = 8 \times 1 = 8$$

$$H_A = H_b = H$$

$$V_a + V_b = 0.5 H_b + 0.5H_a + 4$$

$$V_a + V_b = H + 4$$

$$8 = H + 4 \quad \therefore H = 4 \text{ kN}$$

06. Ans: (c)

Sol:

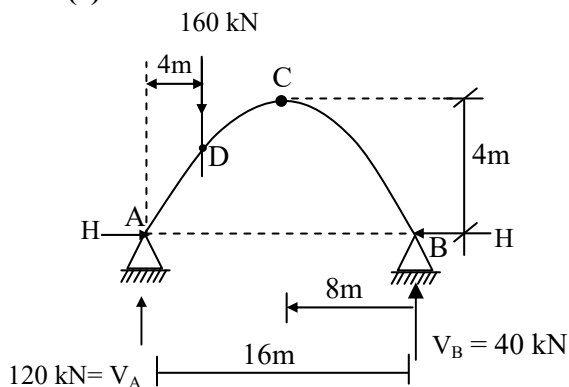

$$\therefore V_A = \frac{160 \times 12}{16} \quad V_B = \frac{160 \times 4}{16}$$

$$= 120 \quad = 40 \text{ kN}$$

Take $\Sigma M_c = 0 \quad H \times 4 = 40 \times 8$

$$\Rightarrow H = 80 \text{ kN.m}$$

Calculation of vertical ordinate at section 'D'

where the point load is acting

$$y = \frac{4h}{l^2} (x)(l - x)$$

$$= \frac{4 \times 4}{16^2} \times (4) \times (16 - 4)$$

$$= \frac{1}{16} \times 4 \times 12 = 3\text{m}$$

Note: The height at quarter of a parabola is

$$= 3h/4$$

$$M_D = 120 \times 4 - 80 \times 3 = 480 - 240$$

$$= 240 \text{ kN-m}$$

07. Ans: (b)

Sol:

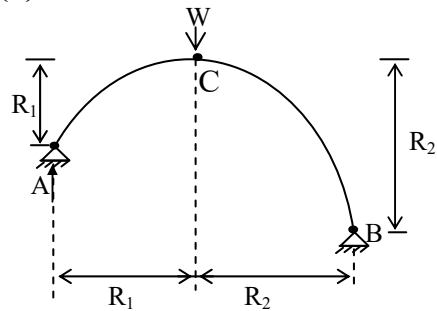

$\Sigma M_C = 0$ from left

$$V_A \cdot R_1 = H \cdot R_1 \Rightarrow V_A = H$$

Similarly $V_B = H$

$$V_A + V_B = 2H = W$$

$$\Rightarrow H = \frac{W}{2}$$

08. Ans: (d)

Sol:

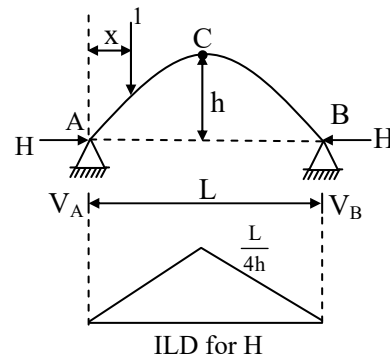



Assume a unit load rolls on the span from left to right. The horizontal and vertical reactions will change at the supports as the load moves on the span.

Assume the unit load be at a distance x from A.

Then

$$V_A = \frac{L-x}{L} \text{ and } V_B = \frac{x}{L}$$

Assume H = The horizontal thrust at supports.

Apply $\Sigma M_C = 0$ from right

$$H \cdot h = \frac{x}{L} \cdot \frac{L}{2}$$

$$\therefore H = \frac{x}{2h}$$

For horizontal thrust to be maximum

$$x = \frac{L}{2} \text{ i.e., at the crown.}$$

\Rightarrow Maximum horizontal reaction of $\frac{L}{4h}$ is

possible if the load is at the crown.

09. Ans: (d)

Sol: When resolved it can be axial force

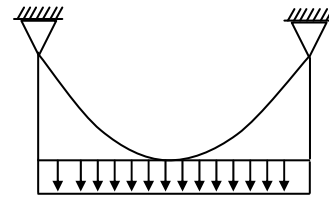
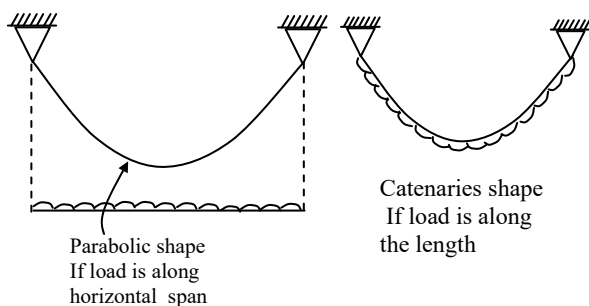

Load transferred from cross girders to the longitudinal girder in cable bridges.

10. Ans: (b)

Sol: Figure shows an arch (either two-hinged or three-hinged arch) subjected to an external load system. Consider any section X . Consider the equilibrium of the part AX of the arch. This part is in equilibrium under the action of the following

- i) Reaction V_a and H at A
- ii) External loads between A and X
- iii) Reacting forces V_x and H_x provided by the part XB on the part XA at X
- iv) Reacting moment (bending moment) at X.

Resolving the forces on the part AX vertically and horizontally, we can determine the vertical and the horizontal reacting forces V_x and H_x at D.

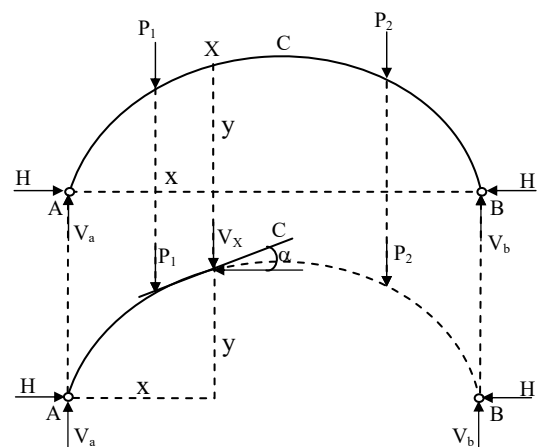

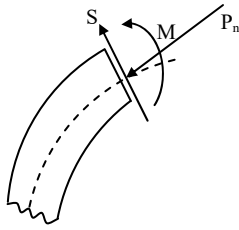

Arch section subjected to normal thrust P_n , radial shear S , bending moment M .

Let the tangent to the centre line of the arch at X be inclined at α to the horizontal.

The component of the reacting forces at X perpendicular to the tangent at X is called the Shear Force (or) Radical Shear at X .

\therefore Shear at $X = S$

$$= H_X \sin \alpha - V_X \cos \alpha \text{ (or) } V_X \cos \alpha - H_X \sin \alpha$$

The component of reacting forces at X along the tangent X is called the Normal thrust at X .

\therefore Normal thrust at $X = P_n = H_X \cos \alpha + V_X \sin \alpha$

($H_X = H$) from F.B.D

(Neglecting sign)

11. Ans: (c)

$$\text{Sol: } \therefore H_{\max} \cdot h = \frac{w}{2} \cdot \frac{l}{2} \Rightarrow H_{\max} = \frac{wl}{4h} S$$

(due to rolling point load)

\therefore In the problem, here. Place 20 kN at centre.

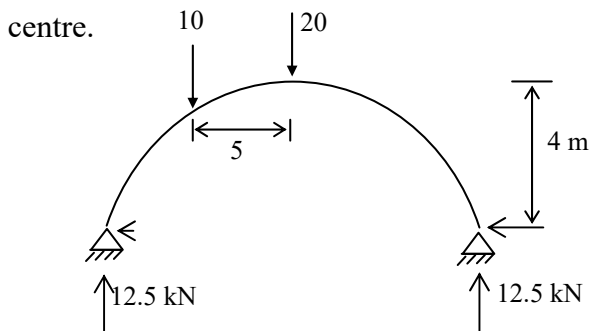

$$\Sigma M_c = 0$$

$$12.5 \times 10 = H \times 4$$

$$H = \frac{12.5 \times 10}{4} = 31.25 \text{ kN}$$

12. Ans: (b)

$$\text{Sol: } V = \frac{wl}{2} = \frac{20 \times 16}{2} = 160 \text{ kN}$$

$$H = \frac{wl^2}{8h} = \frac{20 \times 16}{8 \times 4}$$

$$= 160 \text{ kN}$$

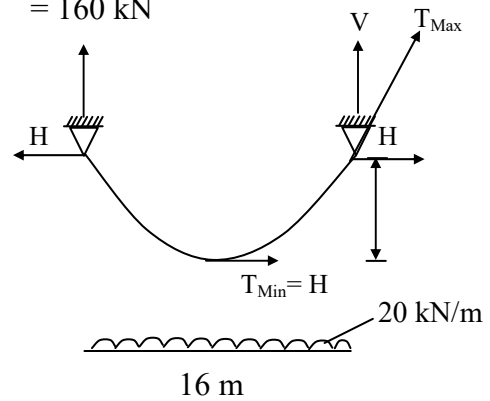

$$T_{\max} = \sqrt{V^2 + H^2} = 160\sqrt{2} \text{ kN}$$

$$T_{\min} = H = 160 \text{ kN}$$

13. Ans: (c)

Sol: When unit load is in b/w A and C

Considering RHS of C.

$$H \times h = V_B \times \frac{L}{2}$$

$$H = \frac{x}{L} \times \frac{L}{2} \times \frac{1}{h} = \frac{x}{2h}$$

When unit load is in b/w C and B.

Considering LHS



$$V_A \times \frac{L}{2} = H \times h$$

$$H = \frac{(L-x)}{L} \times \frac{L}{2h} = \frac{L-x}{2h}$$

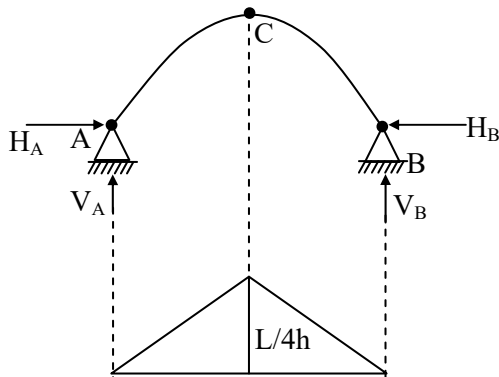

14. Ans: (b)

Sol:

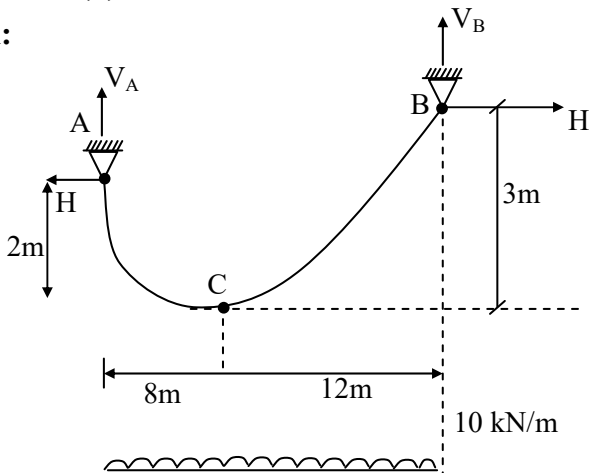

$$\Sigma M_c = 0, \text{ from left}$$

$$V_A \times 8 = H \times 2 + 10 \times 8 \times 4$$

$$V_A = 0.25 H + 40 \quad \dots (1)$$

$$\Sigma M_c = 0 \text{ from right}$$

$$12V_b = 3H + 10 \times 12 \times 6$$

$$V_b = 0.25H + 60 \quad \dots (2)$$

$$V_a + V_b = 200 \text{ kN}$$

$$\therefore 400 = 0.25H + 40 + 0.25 H + 60$$

$$400 = 0.5 H + 100$$

$$\Rightarrow H = 200 \text{ kN}$$

15. Ans: (c)

Sol: H = 200 kN

$$V_b = 0.25 \times 200 + 60$$

$$= 110 \text{ kN}$$

Maximum tension occurs at highest support

(B)

$$\therefore T_{\max.} = \sqrt{H^2 + Vb^2} = \sqrt{110^2 + 200^2}$$

Chapter- 11
Matrix Methods &
Miscellaneous Topics

Class Room Practice Solutions

01. Ans: (b)

$$\text{Sol: } d \propto \frac{1}{EI}$$

$$(EI)' = 2EI$$

\therefore half (b)

02. Ans: (d)

Sol:

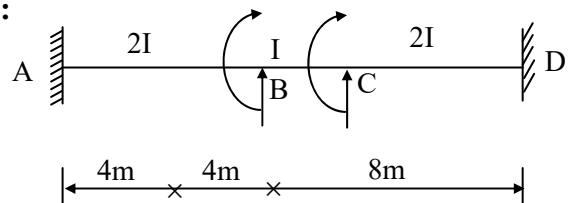

Assume restrained structure at 1 & 2

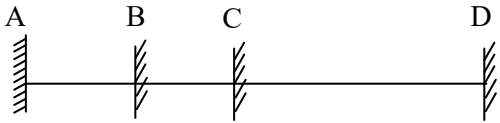

Restrain at 'C'. Apply unit rotation at B

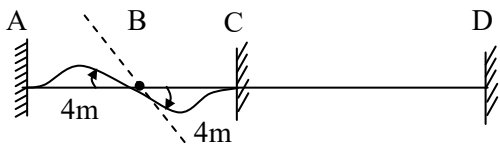

Consider BC

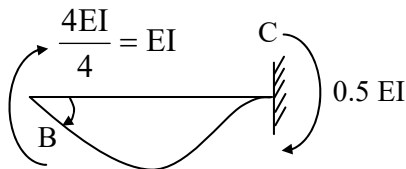

k_{21} = force developed at 1 due to unit rotation at

$$k_{21} = k_{12} = 0.5 EI$$

$$\therefore k = \begin{bmatrix} 3EI & 0.5EI \\ 0.5EI & 2EI \end{bmatrix}$$

03. Ans: (d)

Sol:

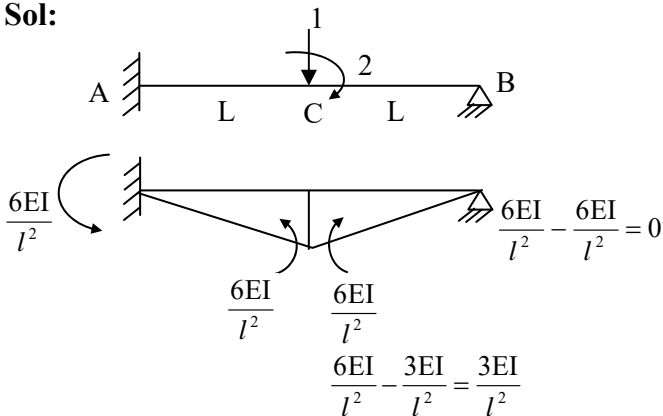

For portion AC (\uparrow) R_B

$$= \frac{6EI}{l^2} + \frac{6EI}{l^2} = \frac{12EI}{l^3}$$

For portion BC (\uparrow) $R_B = \frac{3EI}{l^3} = \frac{3EI}{l^3}$

$$K_{11} = \frac{12EI}{l^3} + \frac{3EI}{l^3} = \frac{15EI}{l^3}$$

$$K_{21} = \frac{-3EI}{l^2}$$

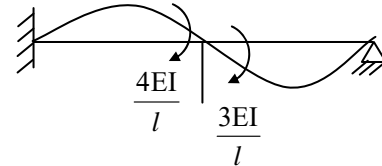
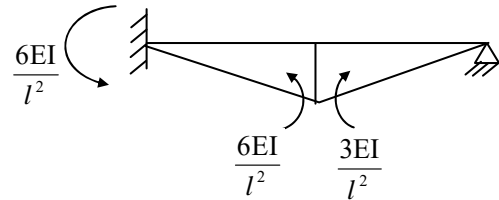

$$K_{22} = \frac{4EI}{l} + \frac{3EI}{l} = \frac{7EI}{l}$$

$$K_{12} = \frac{-6EI}{l^2} + \frac{3EI}{l^2} = \frac{-3EI}{l^2}$$

$$K = \begin{bmatrix} K_{11} & K_{12} \\ K_{21} & K_{22} \end{bmatrix} = \begin{bmatrix} \frac{15EI}{l^3} & \frac{-3EI}{l^2} \\ \frac{-3EI}{l^2} & \frac{7EI}{l} \end{bmatrix}$$



04. Ans: (a)

Sol:

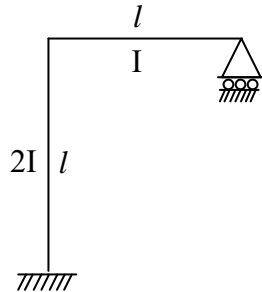

Initially restrain the structure @ co-ordinates 1 & 2.

Allow unit deflection in the direction 1 only.

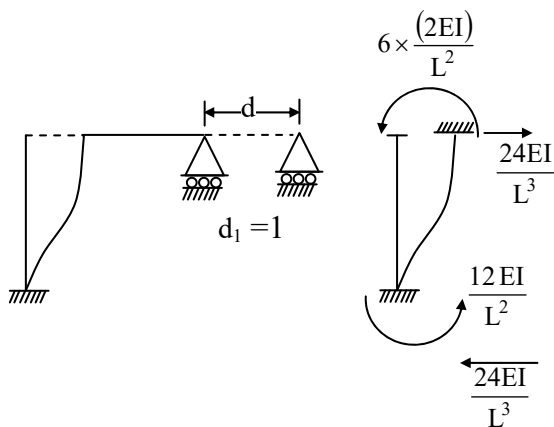

$$\therefore k_{11} = \frac{24EI}{L^3}$$

With this value of k_{11} only option (a).

05. Ans: (d)

Sol:

$$\text{Stiffness} \propto \frac{1}{\text{flexibility}}$$

$\therefore [K] \rightarrow$ Stiffness matrix

$[\delta] \rightarrow$ flexibility matrix

$$\therefore [k] [\delta] = I$$

$$\therefore \text{Flexibility matrix } [\delta] = [k]^{-1}$$

$$\text{Given } [k] = \frac{2EI}{L} \begin{bmatrix} 2 & +1 \\ +1 & 2 \end{bmatrix}$$

$$\therefore \delta = [k]^{-1} = \frac{L}{6EI} \begin{bmatrix} 2 & -1 \\ -1 & 2 \end{bmatrix}$$