

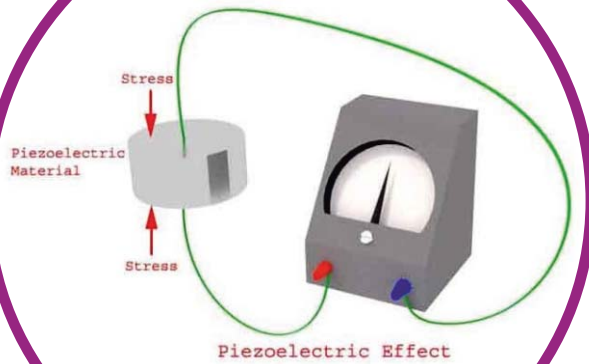

INSTRUMENTATION ENGINEERING



GATE | PSUs

SENSORS &
INDUSTRIAL
INSTRUMENTATION

Volume - I : Study Material with Classroom Practice Questions

Classroom Practice Solutions
To
Sensors & Industrial Instrumentation

CONTENTS

<i>Chapter No.</i>	<i>Name of the Chapter</i>	<i>Page No.</i>
01	Basics of transducers	02 - 02
02	Resistive, Inductive & Capacitive Transducers	03 - 07
03	Piezo Electric Transducers	08 - 10
04	Measurement of Temperature	11 - 15
05	Measurement of Flow & Viscosity	16 - 18
06	Measurement of force and torque	19 - 19
07	Intermediate Quantity Measurement	20 - 20
08	Measurement of Level	21 - 21
09	Measurement of Pressure	22 - 22
10	Miscellaneous	23 - 24

Class Room Practice Solutions

- 01. Ans: (d)
- 02. Ans: (b)
- 03. Ans: (b)

Class Room Practice Solutions

01.

Sol: Given

$$R_m = 2.5 R_p$$

$$\frac{X_t}{2} = X_i$$

$$\frac{R_p}{R_m} = \frac{1}{2.5} = 0.4$$

$$\frac{X_i}{X_t} = \frac{1}{2} = 0.5 = K$$

$$E_L = \frac{K}{1 + K(1 - K) \times \frac{R_p}{R_m}} \times E_i$$

$$= \frac{0.5}{1 + 0.5 \times 0.4 \times 0.5} \times E_i$$

$$= 0.4545 \times E_i$$

$$\text{True value} = K \times E_i$$

$$= 0.5 E_i$$

$$\% \text{ error} = \frac{MV - TV}{TV} \times 100$$

$$= \frac{0.4545 \times E_i - 0.5 E_i}{0.5 E_i} \times 100$$

$$= -0.0917 \%$$

02. **Ans:** 1.1234**Sol:** GivenSlide wire resistance = 10 Ω for 1000 mm

$$\text{For 234 mm length } R = \frac{234}{1000} \times 10 = 2.34 \Omega$$

When dial is at position 11

total resistance = 110 Ω

$$V_x = (110 + 2.34) \times 10 \text{ mA}$$

$$V_x = 1.1234 \text{ Volt}$$

03. **Ans:** (b)**Sol:** We know $R = \frac{\rho L}{A}$ L is increased and becomes αL so, the new resistance is

$$\begin{aligned} R_{\text{new}} &= \frac{\rho L \times \alpha}{\frac{A}{\alpha}} \\ &= \frac{\rho \times L \times \alpha \times \alpha}{A} \\ &= \frac{\rho \times L \times \alpha^2}{A} \\ &= \alpha^2 R \end{aligned}$$

$$\text{So, } R_{\text{new}} = \alpha^2 R$$

04. **Ans:** (a)**Sol:** As we always place the strain gauge experiencing same stress in opposite direction to get maximum output voltage.

05.

Sol: Given

$$R_g = 120 \Omega, G_F = 2.0$$

$$\text{So, } R_1 = 2 \times 100 \times 43.4 \Omega / 100 \text{m}$$

$$= 86.8 \Omega$$

$$\text{We know the relation } \alpha = \frac{R_1}{R_g} = \frac{86.8}{120} = 0.72$$

From formula we know that

$$(G_F)_{\text{eff}} = \frac{G_F}{1 + \alpha} = \frac{2.0}{1.12} = 1.16$$

06. **Ans:** (c)

$$\text{Sol: } \text{CMRR} = \frac{A_d}{A_c} = \frac{\text{differential gain}}{\text{Comm mod gain}}$$



$$\text{CMRR in dB} = 20 \log \left(\frac{A_d}{A_c} \right)$$

$$A_d = 10$$

A_c common mode gain

$$= \frac{\Delta V_0}{\Delta V_i} = \frac{(4-3)\text{mV}}{(3-2)\text{V}} = 1 \times 10^{-3}$$

$$\text{CMRR} = \frac{A_d}{A_c} = \frac{10}{10^{-3}} = 10 \times 10^3 = 10^4$$

07. Ans: (b)

Sol:

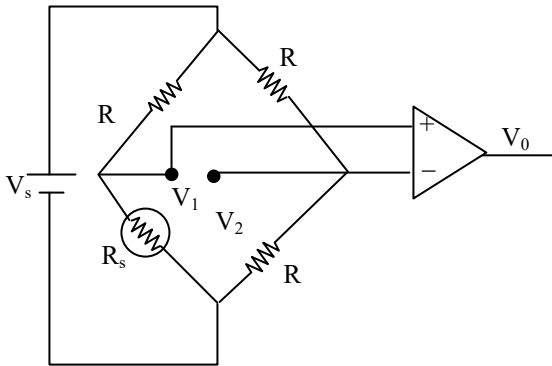

$$V_1 - V_2 = \frac{V_s}{4} \frac{\Delta R}{R} \Rightarrow \frac{V_s}{4} \frac{\pm R \times \frac{1}{100}}{R}$$

$$\Rightarrow \frac{+V_s}{400} \text{ to } \frac{-V_s}{400}$$

$$\Rightarrow 125 \text{ to } -125$$

As the data says the differential amplifier has an additional constant offset voltage at output. Given data for common mode input $V_i = 2\text{V}$ and 3V common mode output $V_0 = 3\text{mV}$ and $V_0 = 4\text{mV}$. Under no load conditions common mode input

$$V_1 = V_2 = 2.5 \text{ (Strain Gauge Resistance } -R)$$

So the common mode input signal becomes 2.5V , hence common mode output signal.

For corresponding 2.5V is

$$\frac{V_0 + V_{02}}{2} = \frac{3\text{mV} + 4\text{mV}}{2} = 3.5\text{mV}$$

If we add this offset to the output of differential amplifier for $R + \Delta R$ is

$$V_0 = 124.3 + 3.5 = 127.8$$

For $R - \Delta R = -125 + 3.5 = -121.5\text{mV}$

So answer is $+128\text{mV}$ to -122mV

08. Ans: (c)

Sol: given

$$\bar{V}_1 = 1.0\text{V} \angle 0^\circ = 1e^{j0} = (\cos 0 + j\sin 0) = 1$$

$$\bar{V}_2 = 1.0\text{V} \angle 10^\circ = 1e^{j10} = (\cos 10 + j\sin 10)$$

$$= 0.984 + j0.173$$

$$V_1 - V_2 = (1 - 0.984) - j0.173$$

$$= 0.016 - j0.173$$

$$|V_1 - V_2| = \sqrt{(0.016)^2 + (0.173)^2}$$

$$= 0.174 \text{ V}$$

09.

Sol: a) for a displacement of 0.5mm , the output is 2mv , so the Sensitivity (s) = $2/0.5 \text{ mv/mm}$
= 4mv/mm

b) for the whole setup, the sensitivity is
 $S = 150 \times 4\text{mv/mm}$
= 1v/mm

c) Given that,

The output of the voltmeter is 5v with 100 divisions which means that each division = $5\text{v}/100 = 0.05\text{V}$

The minimum voltage that can read is $1/5^{\text{th}}$ of a division, so the minimum voltage is

$$= \frac{0.05\text{v}}{5} = 0.01\text{V}$$

Which corresponds to 0.01mm so Resolution 'R' = 0.01mm

10.

Sol: Given $\beta = 250$





$$S_{LVDT} = 1\text{mV}/0.5\text{mm} = 2\text{mV}/\text{mm}$$

$$1\text{mm} \rightarrow 2\text{mV}$$

$$0.25\text{mm} \rightarrow 0.25 \times 2\text{mV}$$

$$E_0 = \beta \times E_{\text{diff}}$$

$$= 250 \times 0.5\text{mV} = 125\text{mV}$$

$$\text{Sensitivity} = \frac{125\text{mV}}{1\text{N}}$$

So, sensitivity of the whole system is

$$\frac{125\text{mV}}{1\text{N}}$$

11. Ans: (b)

Sol:

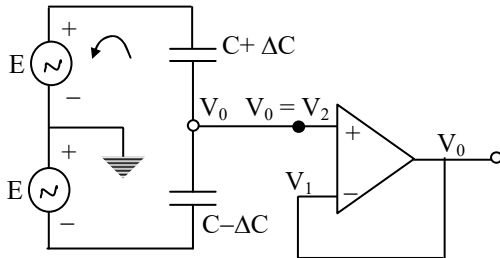

Virtual ground concept

$$V_1 = V_2, \quad V_2 = V_0$$

$$\frac{V_0 - E}{X_{C+\Delta C}} + \frac{V_0 - (-E)}{X_{C-\Delta C}} = 0$$

$$\frac{V_0 - E}{1} + \frac{V_0 + E}{1} = 0$$

$$\frac{V_0 - E}{j\omega(C + \Delta C)} + \frac{V_0 + E}{j\omega(C - \Delta C)} = 0$$

$$(V_0 - E)j\omega(C + \Delta C) + (V_0 + E)j\omega(C - \Delta C) = 0$$

$$j\omega(C - \Delta C) = 0$$

$$V_0 C + V_0 \Delta C - EC = 0$$

$$= EC + V_0 C - V_0 \Delta C + EC - E \Delta C = 0$$

$$2 V_0 C = 2 E \Delta C$$

$$V_0 = E \frac{\Delta C}{C}$$

12. Ans: 3.56

Sol: Given

$$p = 0, d = 4 \text{ mm}, c = 300 \text{ pF},$$

$$p = 500 \text{ kN/m}^2,$$

$$\text{Average deflection} = 0.28 \text{ mm},$$

$$\Delta f = ?$$

$$F = \frac{1}{2\pi\sqrt{Lc}}$$

$$f \propto \frac{1}{\sqrt{c}}$$

So

$$\frac{f_1}{f_2} = \sqrt{\frac{c_2}{c_1}} = \sqrt{\frac{d_1}{d_2}}$$

$$f_2 = f_1 \sqrt{\frac{d_2}{d_1}}$$

$$= 100 \text{ k} \sqrt{\frac{4 - 0.28}{4}} = 96.43 \text{ Hz}$$

$$\Delta f = f_1 - f_2 = 3.56 \text{ Hz}$$

13. Ans: (b)

Sol:

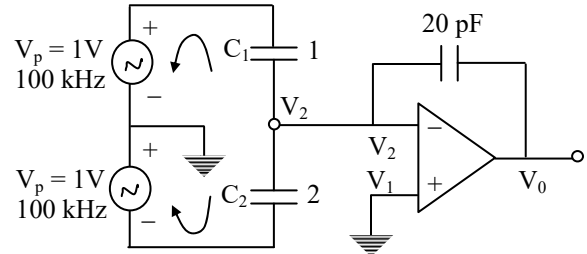

$$V_1 = V_2 \text{ Virtual ground concept}$$

Apply nodal analysis at V_2

$$\frac{V_2 - 1}{X_{C1}} + \frac{V_2(-1)}{X_{C2}} + \frac{V_2 - V_0}{X_{C3}} = 0$$

$$-1(j\omega_{C1}) + 1(j\omega_{C2}) - V_0(j\omega_{C3}) = 0$$

$$V_0(j\omega_{C3}) = j\omega \left[\frac{C_2 - C_1}{C_3} \right]$$

$$V_0 = 0.354 \text{ V}$$

14.
Sol:

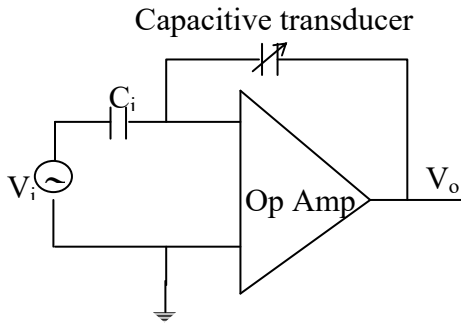

Here $V_o = kx$

$$K = \left(\frac{-C_i}{\epsilon_0 A} V_i \right) \text{V/m}$$

Where K is sensitivity

Given data

$$A = 200 \text{ mm}^2, C_i = 10 \text{ pF}$$

So from the above formula,

The sensitivity =

$$K = \left(\frac{10 \times 10^{-12}}{8.85 \times 10^{-12} \times 200 \times 10^{-6}} \times 10 \right) \text{V/m}$$

$$= 0.057 \times 10^{-6} \text{ V/mm}$$

So output voltage for $1 \mu\text{m}$ is

$$V_o = 0.057 \times 10^{-6} \times 10^{-6}$$

$$= 0.057 \text{V}$$

$$= 57 \text{mV}$$

15.

Sol: From the above figure

$$i = E \times \frac{-c}{x} \cdot \frac{dx}{dt}$$

$$e_0 = -R_f \times i$$

$$e_0 = R_f \times \frac{c}{x} \times E \times \frac{dx}{dt}$$

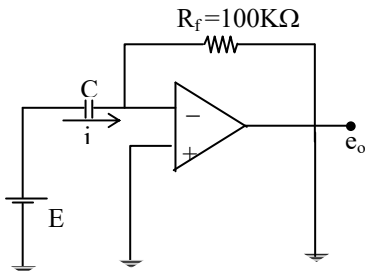

Given data $E = 100 \text{V}$

$$R_f = 100 \text{K}\Omega$$

$$C = 50 \text{ pF}$$

$$X = 5 \text{mm}$$

$$e_0 = \left\{ \frac{100 \times 10^3 \times 50 \times 10^{-12} \times 100}{5 \times 10^{-3}} \right\} \frac{dx}{dt}$$

$$\frac{e_0}{dx} = \frac{100 \times 10^3 \times 50 \times 100}{50 \times 10^{-3}} = 0.1$$

16. Ans: (d)

Sol:

$$V_o = A_d \times V_d$$

$$V_B = \frac{V_s \times \Delta C}{2C}$$

Given $V_o = 10 \text{V}$

$$\Delta C = \frac{5}{100} = 0.05$$

So

$$10 \text{V} = A_d \times \frac{0.05}{2} \times 10$$

$$A_d = \frac{2}{0.05} = 40$$

17. Ans: (b)

Sol: Sensitivity of the measurement system never changes.

18.

Sol: Given $C_0 = C = 0.01 \mu\text{F}$

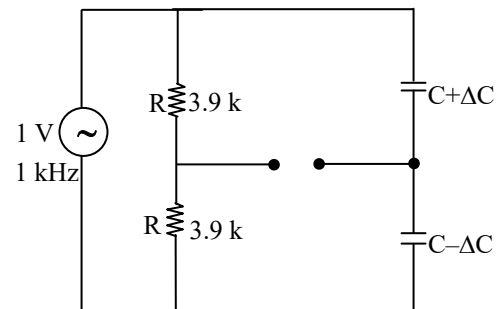



$$V_B = V_s \cdot \frac{\Delta C}{2C}$$

Sensitivity

$$\begin{aligned} \frac{V_B}{\Delta C} &= \frac{V_s}{2C} = \frac{1V}{2 \times 0.01 \mu F} \\ &= \frac{100}{2} V/\mu F \\ &= \frac{50V}{\mu F} = 0.05 \text{ mV/pF} \end{aligned}$$

19.

Sol: For multiple parallel plane capacitive transducers sensitivity is

$$\begin{aligned} S &= \frac{-(n-1)\epsilon_0 \omega}{d} \\ &= \frac{-(5-1) \times 8.85 \times 10^{-12} \times 25 \times 10^{-3}}{0.25 \times 10^{-3}} \\ &= -3.54 \times 10^{-9} \text{ F/m} \\ &= -3.54 \text{ nF/m} \end{aligned}$$

20. **Ans: (b)**

Sol:

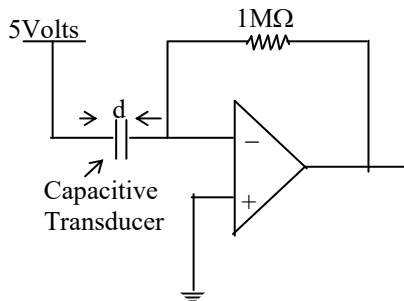

$$X(t) = d(t) = 10^{-3} \{1 + 0.1 \sin(1000\pi t)\} \text{ m}$$

$$d(t) = 10^{-3} \text{ m} + 0.1 \text{ mm} \sin(1000\pi t)$$

$$C = 2 \text{ pF at } t = 0 \text{ m sec}$$

$$C = C_0 \text{ at } 2 \text{ PF}$$

$$i(t) = E \cdot \frac{d}{dt} c(t)$$

$$C = \frac{\epsilon A}{d} = \frac{\epsilon A}{X}$$

$$\frac{dc}{dt} = \frac{-\epsilon A}{X^2} \cdot \frac{dx}{dt}$$

$$= \frac{-C}{X} \cdot \frac{dx}{dt}$$

$$\frac{dx}{dt} = \frac{d}{dt} \{1 \text{ mm} + 0.1 \text{ mm} \sin(1000\pi t)\}$$

$$= \frac{\pi}{10} \cos \omega t$$

$$i(t) = -E \cdot \frac{d}{dt} (c)$$

$$= -E \cdot \frac{C}{X} \cdot \frac{\pi}{10} \cos \omega t$$

$$i(t) = -5V \times \frac{2 \text{ PF}}{1 \text{ mm}} \times \frac{\pi}{10} \cos \omega t$$

$$i(t) = -\pi \cos \omega t \text{ n amp}$$

$$V_0(t) = \pi \cos \omega t \text{ mV} \quad (V_0 = -i(t) \times 1 \text{ M}\Omega)$$

$$V_0(t) = \pi \cos 1000t \text{ (mv)}$$

$$V_0(2 \text{ m sec}) = \pi \cos(2000\pi) \text{ mv}$$

$$V_0 = \pi \text{ mv}$$

21. **Ans: (b)**

$$\text{Sol: } C_1 = \frac{\epsilon_0 \cdot \epsilon_r \times \ell \times \omega}{d}$$

$$C_2 = \frac{\epsilon_0 \times \epsilon_r \times x \times \omega}{d} + \frac{\epsilon_0 \times \epsilon_r \times (\ell - x) \omega}{d}$$

$$\text{Given } 2 C_1 = C_2$$

$$\frac{2 \times \epsilon_0 \cdot \epsilon_r \times \ell \times \omega}{d} = \frac{\epsilon_0 \times \epsilon_r \times x \times \omega}{d} + \frac{\epsilon_0 \epsilon_r (\ell - x) \omega}{d}$$

$$\Rightarrow x = \frac{L}{2}$$

Class Room Practice Solutions

01.

Sol: Given constant 'g' = $12 \times 10^{-3} \frac{\text{V/m}}{\text{N/m}^2}$

Dielectric constant = $1.250 \times 10^{-8} \text{ F/m}$

Young's modulus $E = 1.2 \times 10^{11} \text{ N/m}^2$

$d = 8 \text{ mm}$, $t = 2 \text{ mm}$ and

$$R = 10^8 \Omega$$

a) $g = \frac{K}{\epsilon}$

K is sensitivity in C/N

$$K = g\epsilon = 12 \times 10^{-3} \times 1.25 \times 10^{-8} \\ = 15 \times 10^{-11} \text{ C/N}$$

$$C = \frac{\epsilon A}{t}$$

$$C = 31.41 \times 10^{-11}$$

Sensitivity in V/m = $\frac{K}{C}$

$$= \frac{15 \times 10^{-11}}{31.41 \times 10^{-11}} = 0.477 \text{ V/m}$$

b) If force is 10 N

$$A = \frac{\pi d^2}{4} = \frac{\pi \times (8 \times 10^{-3})^2}{4}$$

$$A = 50.26 \times 10^{-6} \text{ m}^2$$

$$\text{Pressure} = \frac{\text{Force}}{\text{Area}} = \frac{10}{50.26 \times 10^{-6}}$$

$$= 0.198 \times 10^6$$

$$= 19.8 \times 10^4 \text{ N/m}^2$$

$$V_0 = g \times p \times t$$

$$= 12 \times 10^{-3} \times 19.8 \times 10^4 \times 2 \times 10^{-3}$$

$$= 4.752 \text{ V}$$

02.

Sol: $\epsilon = 4 \times 10^{-11} \text{ F/m}$

$$y = 8.6 \times 10^{-10} \text{ N/m}^2$$

$$\Delta t = x = 10^{-9} \text{ m}$$

$$\frac{F}{A} = y \frac{\Delta t}{t}$$

$$F = y \cdot \frac{\Delta t}{t} \cdot A$$

$$F = 8.6 \times 10^{-10} \times 10^{-9} \times \frac{\pi (8 \times 10^{-3})^2}{4} = 1.08 \text{ N}$$

$$C = \frac{\epsilon A}{t} = 0.5 \text{ pF}$$

$$Q = d \cdot f = 2.16 \text{ pC}$$

$$V = \frac{Q}{C_p} = 4.3 \text{ V}$$

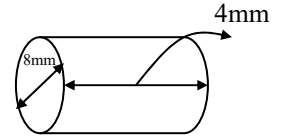
03. **Ans: (a)**

Sol: Given

$$d = 2 \text{ pC/N}$$

$$C_p = 1600 \text{ pF}$$

$$R_p = 1012 \Omega$$

$$F = 0.1 \sin 10t \text{ N}$$

We know for piezoelectric transducer

$$\left| \frac{E}{F} \right| = M = \frac{k}{\sqrt{1 + \left(\frac{1}{\tau \omega} \right)^2}}$$

$$K = \frac{d}{C_p}$$

$$\tau = R_p C_p$$



$$M = \frac{2 \times 10^{-12}}{\sqrt{1 + \frac{1}{(0.1 \times 10)^2}}} = 1.414 \times 10^{-3} \text{ V/N}$$

$$|M| = \frac{E(S)}{F(S)} = 1.141 \frac{\text{mV}}{\text{N}}$$

$$E(s) = M F(s) = \left(1.414 \times \frac{\text{mV}}{\text{N}} \right) \times 0.1 \text{N}$$

$$= 0.141 \text{ mV}$$

04.

Sol: given $t = 2 \text{ mm}$

$$g = 0.05 \text{ Vm/N}$$

$$\frac{F}{A} = 15 \times 10^5 \text{ N/m}^2$$

We know

$$g = \frac{E_0 / t}{F / A}$$

$$\text{So } E_0 = g \times \frac{F}{A} \times t$$

$$= 0.05 \text{ Vm/N} \times 15 \times 10^5 \text{ N/m}^2 \times 2 \times 10^{-3}$$

$$= 150 \text{ V}$$

05. Ans: 2.512 millisecond

Sol: Charge sensitivity $d_{33} = d = 150 \times 10^{-12} \text{ C/N}$

$$C_{pz} = 25 \times 10^{-12} \text{ F}$$

$$R_{pz} = 10^{10} \Omega$$

Input force = $2 \text{ N } u(t)$ (step force)

The Voltage generated

$$= \frac{\text{Charge Generated}}{C_{pz}}$$

$$e_{pz} = e_0 = \frac{d \times F}{C} = \frac{q}{c}$$

$$e_{pz} = \frac{150 \times 10^{-12} \text{ C/N} \times 2 \text{ N}}{25 \times 10^{-12}}$$

$$e_{pz} = 12 \text{ V}$$

The equivalent circuit under the given condition is

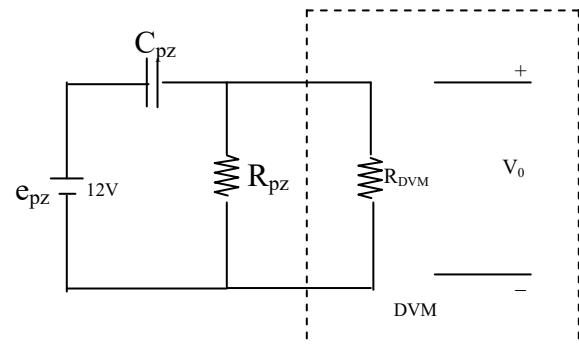

$$\frac{V_0(S)}{e_{pz}(S)} = \frac{\tau s}{\tau s + 1}$$

$$\tau = C_{pz}(R_{pz} \parallel R_{DVM})$$

$$\tau = 20 \text{ PF } (10^{10} \Omega \parallel 10^{13} \Omega)$$

$$\tau = 25 \times 10^{-12} \times 999 \times 10^9 \Omega$$

$$\tau = 0.25 \text{ sec}$$

$$V_0(t) = e_{pz} \times e^{-t/\tau}$$

Where $V_0(t)$ is voltage across the DVM .

Drop allowed from peak value i.e, 12 v is no more than 0.12v. Time at which V_0 falls to 11.88 V must be calculated.

Assigning $V_0(t) = 11.88 \text{ v}$

$$11.88 = 12 \times e^{-\frac{t}{\tau}}$$

$$\frac{11.8}{12} = e^{-\frac{t}{\tau}}$$



$$\Rightarrow \ln\left(\frac{11.88}{12}\right) = \frac{-t}{\tau}$$

$$\Rightarrow \frac{t}{\tau} = \ln\left(\frac{12}{11.88}\right)$$

$$\Rightarrow t = \tau \times \ln\left(\frac{12}{11.88}\right)$$

$$= 0.025 \ln\left(\frac{12}{11.88}\right) \text{ seconds}$$

$$\Rightarrow t = 2.512 \text{ m Seconds}$$

06.

Sol: Given $F = 8 \text{ N}$

$$d = 140 \times 10^{-9} \text{ F/m,}$$

$$\epsilon = 12 \times 10^{-9} \text{ F/m}$$

$$Y = 11.5 \times 10^6 \text{ N/m}^2$$

i) We know

$$\frac{F}{A} = Y \cdot \text{strain}$$

$$\text{Strain} = \frac{F/A}{Y}$$

$$= \frac{8}{36 \times 10^{-6} \times 11.5 \times 10^6}$$

$$= 0.0193$$

ii) Capacitance (c) = $\frac{\epsilon A}{d}$

$$= \frac{12 \times 10^{-9} \text{ F/m} \times 36 \times 10^{-6}}{1.5 \times 10^{-3}}$$

$$= 2.88 \times 10^{-10}$$

$$= 288 \text{ pF}$$

iii) Voltage generated

We know $Q = C.V$

$$V = \frac{Q}{C}$$

Given $d = \frac{Q}{F}$

So, $Q = d \times F$

$$= 1.12 \times 10^{-9} \text{ C}$$

$$V = \frac{Q}{C} = \frac{1.12 \times 10^{-9}}{2.88 \times 10^{-12}} = 3.88 \text{ V}$$

4 Measurement of Temperature

Chapter

Class Room Practice Solutions

01.

Sol: For a first order system

$$T = T_0 \left\{ 1 - \exp\left(\frac{-t}{\tau}\right) \right\}$$

Given $T = 30$, $T_0 = 50^\circ\text{C}$, $\tau = 120\text{sec}$

$$\text{So, } 30^\circ\text{C} = 50^\circ\text{C} \left\{ 1 - \exp\left(\frac{-t}{120}\right) \right\}$$

So $t = 110 \text{ sec.}$

02. Ans: (d)

Sol: $R_T = R_0 [1 + 0.004T]$

True model

$$R_T = R_0 [1 + 0.004T + 6 \times 10^{-7} T^2]$$

Note: measurement model calculated by being measurement value end approximated equation. But true model calculation to based on true value & accurate expression

$$R_T = 100 [1 + 0.004(100 - 0) + 6 \times 10^{-7} (1000)]$$

$$R_T = 140.06 \Omega$$

$$R_T = 102 [1 + 0.004(100)] \text{ ---(1)}$$

$$R_T = 98 [1 + 0.004(100)] \text{ ----(2)}$$

$$e_1 = 142.8 - 140.06 = 2.74 \Omega$$

$$e_2 = 137.2 - 140.06 = -2.86 \Omega$$

03. Ans: (b)

Sol: $10 \text{ mV}/^\circ\text{C}$ – Change in 1°C in RTD output of Bridge 10 mV

$$R_T = R_0 [1 + \alpha T]$$

$$= 100 [1 + 0.00392(1 - 0)]$$

$$R_T = 100.392 \Omega$$

$$V_{\text{out}} = A_d [V_1 - V_2]$$

$$10 \text{ mV} = A_d [V_B]$$

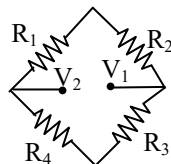

$$V_1 - V_2 = \left(\frac{R_4}{R_2 + R_4} \right) V - \left(\frac{R_3}{R_1 + R_3} \right) V$$

$$\Rightarrow 10 \left[\frac{150.392}{100.392 + 10\text{k}} - \frac{100}{100 + 10\text{k}} \right] = 0.3842 \text{ mV}$$

$$A_d = \frac{10}{0.382\text{V}} = 26.02$$

04. Ans: (b)

Sol: $1^\circ \rightarrow 10 \text{ mV}$ (o/p)

$100^\circ \rightarrow 100 \text{ mV}$ (o/p)

$$= 10 \left[\frac{139.2}{139.2 + 10\text{k}} - \frac{100}{100 + 10\text{k}} \right]$$

$$= 0.03827 \text{ V}$$

Op Amp gain

$$V_0 = 26.02 [V_1 - V_2]$$

$$V_0 = 996 \text{ mV}$$

Error = measured value – True value

$$= 996 \text{ mV} - 1000 \text{ mV}$$

$$= -4 \text{ mV}$$

$1^\circ\text{C} \rightarrow 10 \text{ mV}$

$$1 \text{ mV} \rightarrow \frac{1^\circ}{10} \text{ C}$$

$-4 \text{ mV} \rightarrow -0.4^\circ\text{C}$

05.

Sol: $T_0 \quad 0^\circ\text{C} \rightarrow 100 \Omega = R_0$

$T_1 \quad 100^\circ\text{C} \rightarrow 150 \Omega = R_1$

$T_2 \rightarrow \text{gas temp} \rightarrow 300 \Omega = R_2$



$$\alpha = 0.0039 \text{ C}^{-1}$$

As per the relation

$$\frac{R_{T_2} - R_{T_1}}{T_2 - T_1} = \alpha \cdot R_0$$

$$\frac{300 - 150}{T_2 - 100} = 0.0039 \times 100$$

$$\Rightarrow \frac{150}{0.39} = T_2 - 100$$

$$\Rightarrow T_2 = 384.61 + 100$$

$$T_2 = 484.61 \text{ } ^\circ\text{C}$$

06.
Sol:

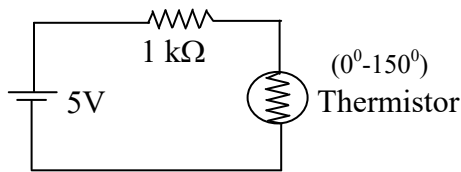

At $25^\circ \rightarrow 10\text{k}\Omega$

$100^\circ \rightarrow 1\text{k}\Omega$

This thermistor is used in a temperature range of $0\text{-}150^\circ\text{C}$. What is the power dissipated at thermistor when operating at more temperature

$$P = I^2 R = \frac{V^2}{R}$$

$$R_T = R_0 e^{\beta \left(\frac{1}{T} - \frac{1}{T_0} \right)}$$

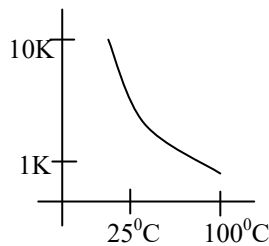

$$\ln \left[\frac{R_T}{R_0} \right] = \beta \left[\frac{1}{T} - \frac{1}{T_0} \right]$$

$$T_0 = 25^\circ\text{C} + 273 = 293\text{k} \rightarrow 10\text{k} = R_0$$

$$T = 100 + 273 = 373\text{k} \rightarrow 1\text{k} = R_T$$

$$\ln \left[\frac{1}{10} \right] = \beta \left[\frac{1}{373} - \frac{1}{298} \right]$$

$$\beta = 3412.55 \text{ k}$$

Now

$$T_0 = 100^\circ\text{C} + 273 = 373 \text{ k} = R_0 = 1\text{k}$$

$$T = 150^\circ\text{C} + 273 = 473 \text{ k} = R_T = ?$$

$$\ln \left[\frac{R_T}{1\text{K}} \right] = 3412.55 \left[\frac{1}{423} - \frac{1}{373} \right]$$

$$R_T = 339.12 \text{ } \Omega$$

Thermistor resistor at 150°C

$$I = \frac{5\text{V}}{1\text{k} + R_{Th}} = \frac{5}{1339.12}$$

$$= 3.733 \times 10^{-3}$$

$$P = I^2 \times R$$

$$P = 4.72 \text{ mV}$$

07.

Sol: $R_t = R_0 a e^{\frac{b}{T}}$

$$\frac{R_t}{R_0} = a e^{\frac{b}{T}}$$

$$\log_e \left\{ \frac{R_T}{R_0} \right\} = \log_e \left\{ a e^{\frac{b}{T}} \right\}$$

$$\log_e \left\{ \frac{R_T}{R_0} \right\} = \log_e a + \frac{b}{T} \log_e e$$

$$\log_e \left(\frac{1050}{4000} \right) = \log_e (300 \times 10^{-6}) + \frac{2850}{T} \times 1$$

$$\Rightarrow -1.337 = -8.11 + \frac{2850}{T}$$

$$\Rightarrow \frac{2850}{T} = 6.78$$

$$\Rightarrow T = \frac{2850}{6.78} = 420.35 \text{ K}$$



08. Ans: -0.04088K^{-1}

Sol: $R = R_\theta = R_{\theta_0} \cdot e^{\beta\left(\frac{1}{\theta} - \frac{1}{\theta_0}\right)}$ for thermistor

$$\theta = 316\text{K} \quad \theta_0 = 298\text{k.}$$

$$R_{316} = 465\text{k}\Omega \quad R_{298} = 1000\Omega$$

$$\frac{dR}{d\theta} = R\theta_0 e^{\beta\left(\frac{1}{\theta} - \frac{1}{\theta_0}\right)} \left(-\frac{\beta}{\theta^2}\right)$$

$$\frac{1}{R} \cdot \frac{dR}{d\theta} = \frac{R\theta_0 \cdot e^{\beta\left(\frac{1}{\theta} - \frac{1}{\theta_0}\right)}}{R\theta_0 \cdot e^{\beta\left(\frac{1}{\theta} - \frac{1}{\theta_0}\right)}} \cdot (-\beta/\theta^2)$$

Sensitivity is $-\frac{\beta}{\theta^2}$ where β must be

calculated. θ is given as 316K.

$$R_\theta = R_{\theta_0} \cdot e^{\beta\left(\frac{1}{\theta} - \frac{1}{\theta_0}\right)}$$

$$R_{316} = R_{298} \cdot e^{\beta\left(\frac{1}{316} - \frac{1}{298}\right)} \text{ to find } \beta$$

$$465\Omega = 1000\Omega e^{\beta(316^{-1} - 298^{-1})}$$

$$\ln(0.465) = \beta(316^{-1} - 298^{-1})$$

$$\beta \cong 4006\text{k}$$

Therefore Sensitivity

$$= -\frac{4006\text{k}}{(316)^2} = -0.0408\text{K}^{-1}$$

09. Ans: (a)

Sol: $2 \frac{dT_i}{dt} + T_i - T_a = 0$

T_i = Indicated temperature

T_a = ambient temperature

The -3 DB cut-off frequency in the frequency response of the thermometer is as

For any problem frequency response allows take Laplace Transform



$$2sT_i(s) + T_i(s) - T_a(s) = 0$$

$$[2s+1]T_i(s) = T_a(s)$$

$$\frac{T_i(s)}{T_a(s)} = \frac{1}{2s+1} = \frac{1}{1+2j\omega}$$

$$|M| = \frac{1}{\sqrt{1+4\omega^2}} = \frac{1}{\sqrt{2}}$$

$$F = \frac{1}{4\pi}$$

10. Ans: (b)

Sol: $C_n\text{-Pt} = -35 \mu\text{V/k}$

a) $\text{pt-C}_n = 35 \mu\text{V/k}$

b) Nichrome - Constantan
= $25 - (-35) = 60$

c) Nickel - constantan
= $-25 - (-35) = 10$

d) $\text{Cu-Ni} = 6+25 = 31$

So maximum sensitivity around 273 k is

Given by (b) Nichrome - constantan

11. Ans: (d)

Sol:

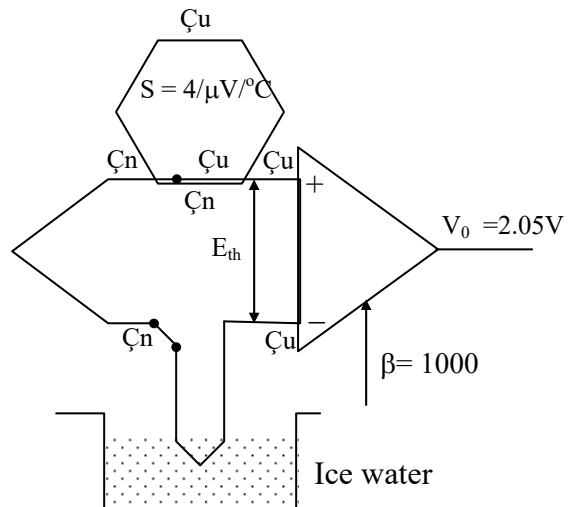

$$\therefore V_0 = \beta V_{in}$$

$$= \beta E_{TH}$$

$$V_0 = \beta S_{TH} [T_H - T_C]$$

$$T_H = 50^\circ\text{C}$$



12. Ans: (b)

Sol:

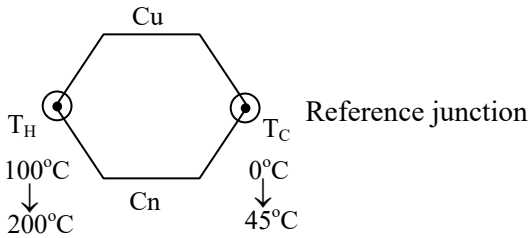

$$E_{TK} = S_{TH} [T_H - T_C]$$

$$T.V = E_{TK} = 53 \mu V [100-0]^\circ C = 53000 \mu V$$

$$M.V = E_{TK} = 53 \mu k [100-45] = 2915 \mu V$$

$$e_1 = \frac{M.V - T.V}{T.V} \times 100 = \frac{2915 - 5300}{5300} \times 100$$

$$e_1 = -45\%$$

$$T.V = E_{TH} = 10600$$

$$M.V = E_{TH} = 8215$$

$$e_2 = -22.5\%$$

13. Ans: (a)

Sol: Given

$$E_{1G} = 53T \mu V$$

$$E_{c_1c_2} = 43T \mu V$$

$$E_{c_2I} = (43T - 53T) \mu V = -10 T \mu V$$

$$E_{c_2I} = -10 \times 70 \mu V = -700 \mu V$$

14. Ans: (d)

Sol: From the table

Sensitivity of thermocouple is

$$S_{TH} = \frac{125 - 35 \mu V}{90 C}$$

$$= 1 \mu V/^\circ C$$

We know the relation

$$E_{TH} = S_{TH} \{T_2 - T_1\}$$

$$48 \mu V = 1 \times \{T_2 - 2^\circ C\}$$

$$\Rightarrow T_2 = 48 + 2$$

$$T_2 = 50^\circ C$$

15.

Sol: For the given thermocouple

Emf

$$\begin{aligned} \text{Emf}_{\text{Chrom-copper}} |_{\text{at } 30^\circ} &= E_{\text{chr-const}} + E_{\text{const-copper}} \\ &= E_{\text{chr-const}} - E_{\text{copper-copper}} \\ &= 1.801 - 1.196 \\ &= 0.605 \text{ mV} \end{aligned}$$

$$\begin{aligned} E_{\text{Hot}} &= V_0 + E_{\text{chrom-copper}} \\ &= 26.74 \text{ mV} + 0.605 \text{ mV} \\ &= 27.345 \text{ mV} \end{aligned}$$

Temperature corresponding to 27.345mV is $380^\circ C$

16. Ans: 1.2 to 1.3 mV

Sol:

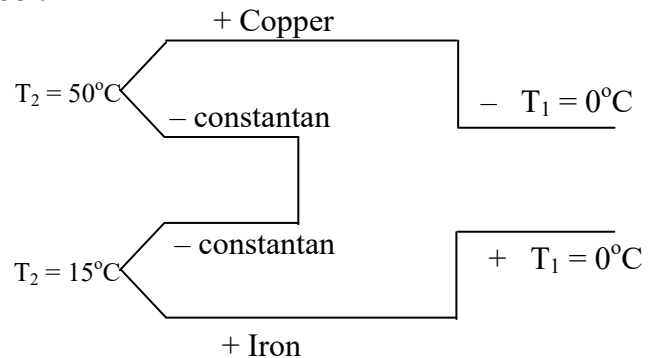

A = copper, B = constantan, C = iron

$$e_A = 1.9 \mu V/^\circ C \text{ with respect to platinum}$$

$$e_B = -38.3 \mu V/^\circ C \text{ with respect to platinum}$$

$$e_C = 13.3 \mu V/^\circ C \text{ with respect to platinum}$$

$$E_{AB} = e_{A/B} \cdot T_2^\circ C$$

$$= 40.2 \mu V/^\circ C \times 50^\circ C$$

$$E_{AB} = 2.01 \text{ mV}$$



Similarly

$$E_{CB} = e_{C/B} \times T_3^{\circ}C = 51.6 \mu V/^{\circ}C \times 15^{\circ}C \\ = 0.774 mV.$$

$$\therefore E_0 = E_{CB} - E_{AB} = -1.236 mV.$$

$$|E_0| = 1.236 mV.$$

17. Ans: 77

$$\text{Sol: } V_0 \left(\frac{1k}{2k+1k} \right) = \frac{V_0}{3} = \frac{2.1}{3} = 0.7 = V_+ \quad (\text{virtual}$$

and concept)

$$I = \frac{V_+}{2k} = 0.35 mA = T \mu A$$

$$T = 350 K$$

$$T = 77^{\circ}C$$

18. Ans: 1612

Sol: Given data:

$$\text{Sensitivity} = 10 \left(\frac{\mu V}{^{\circ}C} \right)$$

Thermocouple measures 10mV at $t = \tau = 1 \text{ sec}$

As given system is first order we use first order system equation

$$y(t) = AK(1 - e^{-t/\tau})$$

A = amplitude = final temperature – initial temperature

$$A = \theta_f - \theta_i = (\theta_f - 30)^{\circ}C$$

y(t) = temperature measured at time t

$$10 \times 10^{-3} = (\theta_f - 30) \times 10 \times 10^{-6} \times (1 - e^{-1})$$

$$\theta_f = 1612^{\circ}C$$

19. Ans: 0.2

Sol: KCL at inverting terminal:-

$$\frac{0-12}{R(1+x)} + \frac{0+12}{R} + \frac{0-V_0}{R} = 0$$

$$\{\text{Given } V_0 = +2\}$$

$$x = 0.2$$

Class Room Practice Solutions

01. Ans: (b)

Sol: $P_1 - P_2 = 30 \text{ kPa}$

$$Q = 50 \text{ lts}$$

$$P_1 - P_2 = 20 \text{ kPa}$$

By Bernoullis equation

$$\frac{P_1}{\rho g} + \frac{V_1^2}{2g} = \frac{P_2}{\rho g} + \frac{V_2^2}{2g} + 0.4$$

$$\Rightarrow \frac{30}{1000 \times 9.8} = \frac{V_2^2 - V_1^2}{2g} + 0.4$$

(By assuming $V_1 = 0$) $V_2 = 7.2 \text{ m/sec}$

$$\frac{20}{1000 \times 9.8} = \frac{(V_2')^2}{2g} + 0.4$$

$$V_2' = 5.67 \text{ m/sec}$$

$$\frac{Q_1}{Q_2} = \frac{V_2}{V_2'}$$

$$\Rightarrow \frac{50}{Q_2} = \frac{7.22}{5.67}$$

$$Q = 39.27 \text{ lt/sec}$$

02. Ans: 4.45

Sol: $Re = \rho \frac{dv}{\mu}$

$$Q = Av$$

$$V = Q/A = \frac{\text{mass rate}}{\rho \times A}$$

$$\rho = \frac{\text{mass}}{\text{volumerate}}$$

$$\text{Volume rate} = \frac{\text{mass}}{\rho}$$

$$Re = \frac{\rho \times d \times \text{massrate}}{\mu \times \pi \times d}$$

$$d = 4.45 \text{ cm}$$

03. Ans: (d)

04. Ans: (c)

05. Ans: (d)

Sol: Using Pitot-static tube, flow velocity of fluid is given by

$$V = \sqrt{\frac{2(p_{\text{stag}} - p_{\text{stat}})}{\rho}}$$

Given density, $\rho = 1000 \text{ kgm}^{-3}$

$$p_{\text{stag}} - p_{\text{stat}} = 10 \text{ kPa} = 10^4 \text{ N/m}^2$$

$$\therefore V = \sqrt{20} \text{ m/sec} = V_1$$

Pipe dia, $d = 0.05 \text{ m}$

$$\text{Area, } A_1 = \frac{\pi d^2}{4}$$

Cylindrical drum dia, $D = 1 \text{ m}$

$$\text{Area, } A_2 = \frac{\pi D^2}{4}$$

If the rate of reduction in water level in the drum is V_2 ,

$$V_1 A_1 = V_2 A_2$$

$$V_2 = V_1 \frac{A_1}{A_2} = \frac{\sqrt{20} (0.05)^2}{(1)^2} = \frac{1}{40\sqrt{5}} \text{ m/s}$$

06. Ans: (d)

Sol:

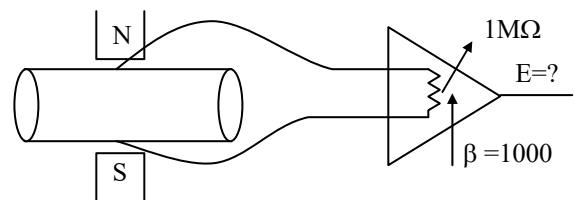

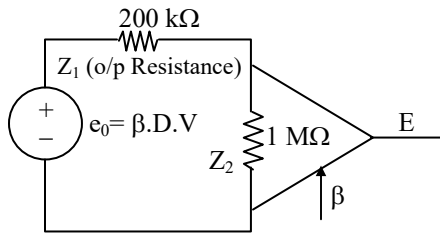

$$E = (\beta) \cdot E_{in}$$

$$= \beta \left[\frac{1M\Omega}{200k\Omega + 1M\Omega} \right] e_0 = 0.833V$$

07. Ans: (c)

Sol: Given $\Delta t = 10 \times 10^{-9}$ sec

$$V_s = 1000 \text{ m/sec}$$

$$d = 25 \text{ mm}$$

$$\theta = 60^\circ$$

$$\text{So, } V_f = \frac{\Delta t \times V_s^2}{29 \cos \theta}$$

$$= \frac{10 \times 10^{-9} \times (1000)^2}{2 \times 25 \times 10^{-3} \times \cos(60^\circ)}$$

$$= 0.4 \text{ m/sec}$$

08.

Sol: $\Delta t = \frac{1}{5 \text{ MHz}} = 0.2 \mu \text{ sec}$

$$v_s = 1500 \text{ m/sec}$$

$$V_f = ?$$

d = distance between crystals

From the questions we can draw the figure

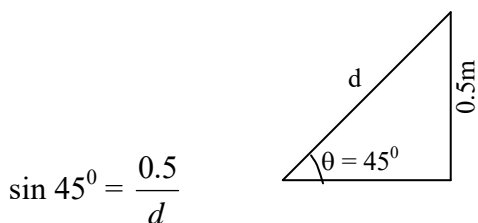

$$d = \frac{0.5}{\sin 45^\circ} = 0.7 \text{ m}$$

$$\Delta t = \frac{2d v_f \cos \theta}{V_s^2}$$

$$v_f = \frac{\Delta t \times v_s^2}{2d \cos \theta}$$

$$v_f = \frac{0.2 \times 10^{-6} \times (1500)^2}{2 \times 0.7 \times \cos 45^\circ}$$

$$v_f = 0.45 \text{ m/sec}$$

09. Ans: (b)

Sol: Induced voltage of turbine flow meter is

$$E = \beta \cdot n \cdot \omega$$

where, β = amplitude of time varying flux.

α = mean flux

n = no. of teeth on wheel

given, speed N = 72 rpm.

$$\alpha = 3, \beta = 1 \text{ and } n = 4$$

$$\omega = \frac{2\pi N}{60} = 7.536$$

$$\text{now, } E = 7.5 \times 1 \times 4 = 30.144$$

10.

Sol: given

$$\rho_{oil} = 900 \text{ kg/m}^3$$

$$\mu = 0.006 \text{ Ns/m}^2$$

$$L = 30 \text{ cm}$$

$$\Delta P = s \times g \times h$$

$$= 900 \times 9.8 \times 20 \times 10^{-2} = 1764$$

$$Q = \frac{\pi D^4}{128L} \cdot \frac{\Delta p}{\mu}$$

$$= \frac{\pi \times (2 \times 10^{-2})^4 \times 1764}{128 \times 30 \times 10^{-2} \times 0.006}$$

$$= 38.5 \text{ cm}^3$$



11. Ans: (a)

Sol: For U type manometer

$$f = \frac{1}{2\pi} \sqrt{\frac{2g}{L}}$$

$$V = a_m \times L$$

$$= \frac{\pi D^2}{4} \times L$$

$$\Rightarrow L = \frac{4V}{\pi D^2}$$

$$\Rightarrow f_n = \frac{2g}{\sqrt{\frac{4V}{\pi D^2}}}$$

$$= \frac{1}{2\pi} \sqrt{\frac{2g \cdot \pi D^2}{4V}}$$

$$= \frac{D}{2\sqrt{2\pi}} \sqrt{\frac{g\pi}{V}}$$

$$= \frac{D}{2\sqrt{2\pi}} \sqrt{\frac{g}{V}}$$

12. Ans: 1.9634

Sol: $e = B/V = 100 \times 10^{-3} \times 0.25 \times V$

$$1 = 0.25 \times 10^{-1} V$$

$$V = 40 \text{ (m/sec)}$$

$$Q = AV = \frac{\pi}{4} d^2 \times V = \frac{\pi}{4} \times (0.25)^2 \times 40$$
$$= 1.9634 \text{ (m}^3 \text{ / sec)}$$

6 Measurement of force & torque

Class Room Practice Solutions

01. Ans: (b)

Sol: given

$$g = 50 \times 10^{-3}$$

$$A = 4 \text{ cm}^2$$

$$\tau = 20 \text{ Nm (force} \times \text{length)}$$

We know

$$g = \frac{E_0 / t}{\frac{F}{A}}$$

$$\tau = \vec{F} \times \vec{L}$$

$$L = 0.5 \text{ m given}$$

$$F = \frac{\tau}{L} = 40 \text{ N}$$

$$E_0 = g \times \frac{F}{A} \times t$$

$$E_0 = 50 \times 10^{-3} \times \frac{40}{4 \times (10^{-2})^2} \times 1 \times 10^{-3}$$

$$= 5 \text{ V}$$

02. Ans: 848 Nm

Sol: We know

$$\text{Angle of shear } \theta = \frac{2T}{\pi Gr^3}$$

Where G is shaft shear mode

r is the radius of shaft

T is the applied torque

An area of shaft surface, originally square with the sides of unit length and deformed to parallelogram due to the application of strain.

The original length of diameter is T_2 and if θ is small then change in length is $\frac{\theta}{\sqrt{2}}$

So

$$\varepsilon = \frac{\Delta L}{L} = \frac{\frac{\theta}{\sqrt{2}}}{\frac{\theta}{\sqrt{2}}} = \frac{\theta}{2}$$

$$\text{but, } \frac{\Delta R}{R} = Gf \varepsilon = 2 \times \frac{\theta}{2} = \theta$$

$$\text{Or } \theta = \frac{\Delta R}{R} = \frac{0.24}{120} = 2 \times 10^{-3} \text{ rad}$$

$$T = \frac{\pi Gr^3}{2} \times \theta$$

$$\theta = \frac{\pi \times 80 \times 10^9 \times (15 \times 10^{-3})^3 \times 2 \times 10^{-3}}{2}$$

$$= 848 \text{ Nm.}$$

Class Room Practice Solutions

01.

Sol: Input range = 0 to 5 g

Damping ratio = 0.8

Output range = 0 to 10 V

 $m = 0.005 \text{ kg}$ $k = 20 \text{ N/m}$

i) input displacement range

$$\frac{m}{k} = \frac{x}{\text{acc}}$$

$$\Rightarrow \frac{0.005 \text{ kg}}{20 \text{ N/m}} = \frac{x}{5 \times 10^{-3} \times 9.81 \text{ m/sec}^2}$$

$$\Rightarrow x = 12.2625 \text{ mm}$$

ii) 1 k Ω POT

$$X_i = \frac{0.005}{20} \times 2 \times 10^{-3} \times 9.81$$

$$= 4.905 \times 10^{-3} \text{ for } 2g \text{ acceleration}$$

$$= 0.0049 \text{ m}$$

$$k = \frac{x_i}{x_t} = \frac{0.0049}{0.0126} = 0.388$$

$$\frac{R_p}{R_m} = \frac{1 \text{ k}}{10 \text{ k}} = 0.1$$

$$\% \text{ LE} = \frac{MV - TV}{TV} \times 100$$

$$MV = \frac{0.38 E_i}{1 + 0.38(1 - 0.38) \times 0.1}$$

$$TV = 0.38 E_i$$

$$\begin{aligned} \% \text{ error} &= \frac{\frac{0.38 E_i}{1 + 0.38(1 - 0.38) \times 0.1} - 0.4 E_i}{0.4 E_i} \times 100 \\ &= -2.36 \% \end{aligned}$$

02.

Sol: For accelerometer ratio of amplitude of output and input

$$\begin{aligned} \frac{(x_2 - x_1)0}{x_{m1}} &= \frac{u^2}{\sqrt{(1 - u^2)^2 + (2\xi u)^2}} \\ &= \frac{u^2}{\sqrt{(1 - u^2)^2 + (2 \times 0.7u)^2}} = 0.99 \end{aligned}$$

$$u = \text{normalized frequency} = \frac{\omega_1}{\omega_2} = 2.45$$

Class Room Practice Solutions

01.

Sol: Given $l = 8$ m
 $h = 7$ m
 $\epsilon_{r \text{ liq}} = 2.4$

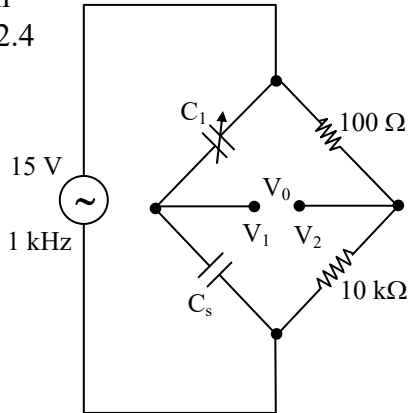

tank is empty

$$C_s = \frac{2\pi\epsilon_0\ell}{\ln\left(\frac{D_1}{D_2}\right)}$$

$$= \frac{2\pi \times 8.85 \times 10^{-12} \times 8}{\ln(2)}$$

$$= 642 \text{ pF}$$

For bridge balance condition

$$Z_1 Z_4 = Z_2 Z_3$$

$$(XC_1) \times (10 \text{ k}\Omega) = (100 \Omega) \times (XC_s)$$

$$\frac{1}{j\omega C_1} \times (10 \text{ k}\Omega) = 100 \times \frac{1}{j\omega C_s}$$

$$C_1 = \frac{C_s \times 10 \text{ k}}{100}$$

$$C_1 = 64.2 \text{ nF}$$

ii) When tank is full

$$C_s = \frac{2\pi\epsilon_0}{\ln\left(\frac{D_1}{D_2}\right)} (\epsilon_{r1} h_1 + \epsilon_{r2} h_2)$$

$$= \frac{2\pi \times 8.85 \times 10^{-12}}{\ln(2)} \times \{(2.4) \times 7 + 1\}$$

$$\Rightarrow C_s = 1425 \text{ pF}$$

$$V_0 = V_1 - V_2$$

$$= 15 \text{ V} \left(\frac{64.2 \text{ nF}}{64.2 \text{ nF} + 1425 \text{ pF}} - \frac{10 \text{ k}}{10 \text{ k} + 100 \Omega} \right)$$

$$= 0.177 \text{ V.}$$

02. Ans: (c)

Sol: A_w = Area of water

$$P_1 = P_2$$

$$\sin\theta = \frac{h_d}{\ell + y}$$

$$l \sin\theta + y \sin\theta = h_d \text{ ---- (1)}$$

$$\sin\theta = \frac{AB}{y}$$

$$AB = y \sin\theta \text{ ---- (2)}$$

By law of volume

Volume of mercury lost in well = volume of mercury gain in cap

$$a_w \times AB = a_t \times l$$

$$a_w \times y \sin\theta = a_t \times l$$

$$y \sin\theta = \frac{a_t}{a_w} \times l \text{ ---- (3)}$$

from (2) & (3)

$$\sin\theta = \frac{h_d}{\ell} - \frac{a_t}{a_w}$$

$$\theta = \sin^{-1} \left[\frac{h_d}{\ell} - \frac{a_t}{a_w} \right]$$

$$\sin\theta = h_d - AB$$

Class Room Practice Solutions

02. 32520

01.

Sol: We know for diaphragm pressure gauge

$$Y_{\max} = t/3 = \frac{3\Delta P}{16Et^3} r^4 (1 - \mu^2)$$

$$t^4 = \frac{9\Delta P r^4 (1 - \mu^2)}{16Et^3}$$

$$= \frac{9 \times 1.5 \times 10^6 \times 2.5^4 \{1 - (0.3)^2\}}{16 \times 200 \times 10^9}$$

$$= 149.96 \times 10^{-6} \text{cm}^4$$

$$t = 0.1106 \text{cm}$$

Class Room Practice Solutions

01.

Sol: Let X dB and Y dB be the sound pressure levels from the sound sources.

Then the noise level with both sources operating together is given by

Combined spl

$$= 10 \log_{10} \left[\text{anti log} \left(\frac{X}{10} \right) + \text{anti log} \left(\frac{Y}{10} \right) \right]$$

$$= 10 \log_{10} \left[\text{anti log} \left(\frac{78}{10} \right) + \text{anti log} \left(\frac{82}{10} \right) \right]$$

$$= 10 \log_{10} [6.31 \times 10^7 + 15.85 \times 10^7]$$

$$= 10 \log_{10} [22.16 \times 10^7] = 10 \times 8.3456$$

$$= 83.456 \text{ dB}$$

02.

Sol: Resultant spl = $10 \log_{10} \left[\text{anti log} \left(\frac{X}{10} \right) + \text{anti log} \left(\frac{Y}{10} \right) \right]$

Substituting the numerical values from the given data,

$$85 = 10 \log_{10} \left[\text{anti log} \left(\frac{X}{10} \right) + \text{anti log} \left(\frac{73}{10} \right) \right]$$

Where X dB is the sound pressure level of the machine.

$$\therefore \text{anti log} \left(\frac{X}{10} \right) = \text{anti log} \left(\frac{85}{10} \right) - \text{anti log} \left(\frac{73}{10} \right)$$

Take \log_{10} of both sides

$$X = 10 \log_{10} [\text{anti log} 8.5 - \text{anti log} 7.3]$$

$$X = 10 \log_{10} [3.612 \times 10^8 - 0.1995 \times 10^8]$$

$$X = 10 \log_{10} [2.9625 \times 10^8] = 10 \times 8.4717 \\ = 84.717 \text{ dB}$$

Thus the sound pressure level of the machine alone is 84.717 dB.

03. Ans : -20K

04. Ans: 8cm

Sol: Area target factor

$$= \frac{\text{distance or receiver from target}}{\text{useful diameter of target}}$$

$$\therefore \text{Diameter of target} = \frac{160}{20} = 8 \text{ cm}$$

05.

Sol: Absolute temperature with emissivity of 0.82 is

$$= 1065 + 273 = 1338^0 \text{ k}$$

\therefore Apparent absolute temperature is,

$$T_a = (0.82)^{-1/4} (1338) = 1273^0 \text{ k}$$

Actual absolute temperature when the emissivity is 0.75

$$= (0.75)^{-1/4} (1273) = 1368^0 \text{ k}$$

Actual temperature

$$= 1368 - 273 = 1095^0 \text{ C}$$

Hence error in temperature measure

$$= 1065 - 1095 = -30^0 \text{ C.}$$



06. Ans: (b)

Sol:

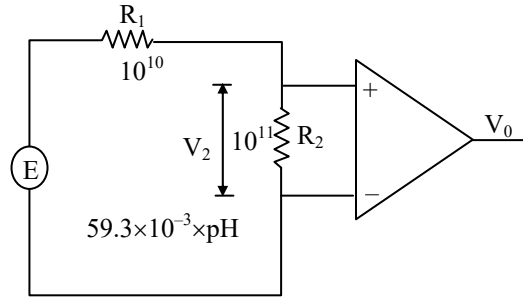

$$V_0 = \beta \times V_2$$

$$= \beta \times \frac{R_2}{R_1 + R_2} \times E$$

$$V_{01} = \beta \times \left(\frac{R_2}{R_1 + R_2} \right) \times 59.3 \times 10^{-3} \times 6.5$$

$$= 100 \times \frac{10^{11}}{10^{10} + 10^{11}} \times 59.3 \times 10^{-3} \times 6.5$$

$$= 35.04 \text{ V}$$

$$V_{02} = \beta \times \left(\frac{R_2}{R_1 + R_2} \right) \times 59.3 \times 10^{-3} \times 7.8$$

$$= 100 \times \frac{10^{11}}{10^{10} + 10^{11}} \times 59.3 \times 10^{-3} \times 7.8$$

$$= 42.04 \text{ V}$$

$$\Delta V = 42.04 - 35.04 = 7 \text{ V}$$

07.

Sol:

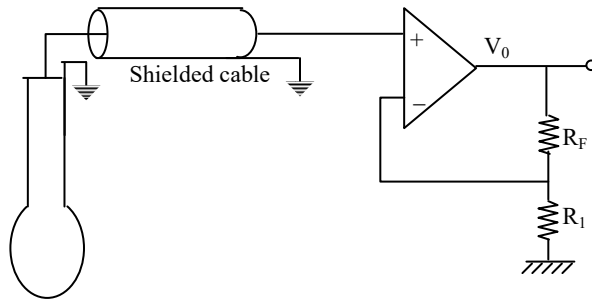

pH electrode

Given

$$R = R_i \left(1 + A_0 \frac{R_F}{R_1} \right)$$

$$R_i = 10^6 \Omega, \quad R_{\text{electrode}} = 10^9 \Omega$$

$$A_0 = 10^5, \quad R_{\text{cable}} = 10^9 \Omega$$

$$R = 10^6 \left(1 + 10^5 \times \frac{1}{1} \right) \approx 10^{11} \Omega$$

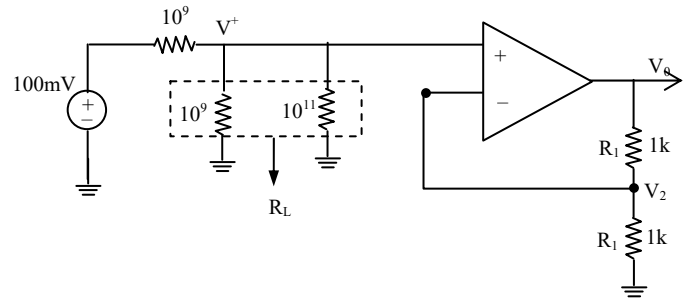

$$R_L = 10^9 \parallel 10^{11} = 0.99 \times 10^9 \Omega$$

$$V^+ = 100 \text{ mV} \times \frac{R_L}{R_L + 10^9}$$

$$V^+ = 49.75 \text{ mV}$$

$$V_0 = \left(1 + \frac{R_F}{R_1} \right) V^+ = 99.5 \text{ mV}$$

08. Ans: 118.4mV

Sol: Sensitivity of pH electrode is approximately is around 59.2mV/pH at 25°C ambient Temperature.

Therefore output of the pH electrode at 6 pH is 355.2 mV and at 8 pH it is 473.6mV
The change in voltage is 118.4mV.