

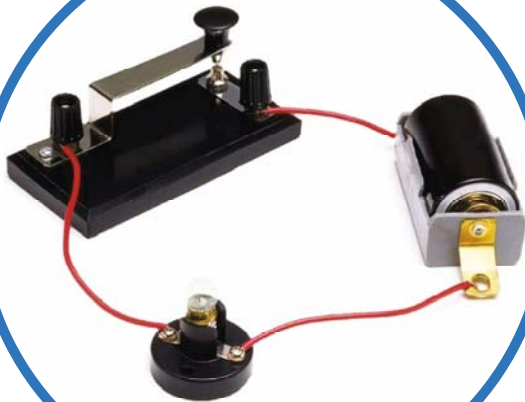

ELECTRONICS & COMMUNICATION ENGINEERING



GATE | PSUs

NETWORK THEORY

Volume - I : Study Material with Classroom Practice Questions

Study Material with Classroom Practice solutions*To****Network Theory******CONTENTS***

<i>Chapter No.</i>	<i>Name of the Chapter</i>	<i>Page No.</i>
01	Basic Concepts	03 - 14
02	Circuit Theorems	15 - 24
03	Transient Circuit Analysis	25 - 39
04	AC Circuit Analysis	40 - 49
05	Magnetic Circuits	50 - 51
06	Two Port Networks	52 - 57
07	Graph Theory	58 - 59
08	Passive Filters	60 - 61

Chapter 1

Basic Concepts

Class Room Practice Solutions

01. Ans: (c)

Sol: We know that;

$$i(t) = \frac{dq(t)}{dt}$$

$$dq(t) = i(t) \cdot dt$$

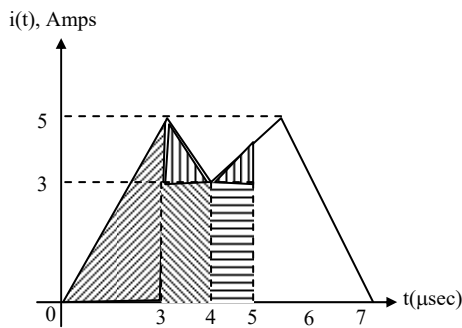

$$q = \int_0^{5 \mu\text{sec}} i(t) dt = \text{Area under } i(t) \text{ upto } 5 \mu\text{sec}$$

$$q = q_1 + q_2 + q_3$$

$$= \left(\frac{1}{2} \times 3 \times 5\right) + \left(\frac{1}{2} \times 1 \times 2 + (1 \times 3)\right) + \left(\frac{1}{2} \times 1 \times 1 + (1 \times 3)\right)$$

$$q = 15 \mu\text{c}$$

02. Ans: (a)

Sol:

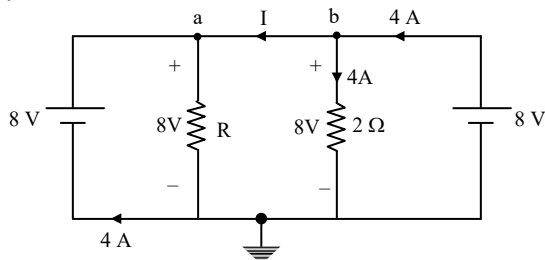

Applying KCL at node 'b'

$$I + 4 = 4$$

$$\Rightarrow I = 0\text{A}$$

$$\text{and } \frac{8}{R} = 4$$

$$\Rightarrow R = 2\Omega$$

03. Ans: (a)

Sol: The energy stored by the inductor (1Ω , 2H) upto first 6 sec:

$$E_{\text{stored upto 6sec}} = \int P_L dt$$

$$= \int \left(L \frac{di(t)}{dt} \cdot i(t) \right) dt$$

$$= \int_0^2 \left(2 \left[\frac{d}{dt}(3t) \right] \times 3t \right) dt + \int_2^4 \left(2 \left[\frac{d}{dt}(6) \right] \times 6 \right) dt$$

$$+ \int_4^6 \left(2 \left[\frac{d}{dt}(-3t+18) \right] \times (-3t+18) \right) dt$$

$$= \int_0^2 18t dt + \int_2^4 0 dt + \int_4^6 (-6[-3t+18]) dt$$

$$= 36 + 0 - 36 = 0 \text{ J}$$

(or)

$$E_{\text{stored upto 6sec}} = E_L |_{t=6\text{sec}}$$

$$= \frac{1}{2} L (i(t) |_{t=6})^2$$

$$= \frac{1}{2} \times 2 \times 0^2 = 0 \text{ J}$$

04. Ans: (d)

Sol: The energy absorbed by the inductor (1Ω , 2H) upto first 6sec:

$$E_{\text{absorbed}} = E_{\text{dissipated}} + E_{\text{stored}}$$

Energy is dissipated in the resistor

$$E_{\text{dissipated}} = \int P_R dt = \int (i(t))^2 R dt$$



$$= \int_0^2 (3t)^2 \times 1 dt + \int_2^4 (6)^2 \times 1 dt + \int_4^6 (-3t + 18)^2 \times 1 dt$$

$$= \int_0^2 9t^2 dt + \int_2^4 36 dt + \int_4^6 (9t^2 + 324 - 108t) dt$$

$$= 24 + 72 + 24$$

$$= 120J$$

$\therefore E_{\text{dissipated}} = 120 J$

And $E_{\text{stored upto 6sec}} = 0J$

$\therefore E_{\text{absorbed}} = E_{\text{dissipated}} + E_{\text{stored}}$
 $\Rightarrow E_{\text{absorbed}} = 120J + 0J = 120J$

05. Ans: (a)

Sol: Point $(-20, 0) \Rightarrow V = -20V$ and $I = 0A$

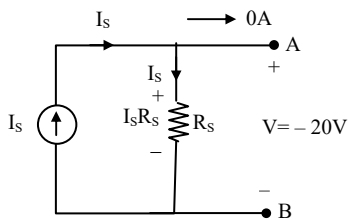

By KVL $\Rightarrow I_S R_S - V = 0$

$\Rightarrow I_S R_S + 20 = 0$

$\Rightarrow I_S R_S = -20V \dots\dots\dots (1)$

Point: $(0, -2) \Rightarrow V = 0V$ and $I = -2A$

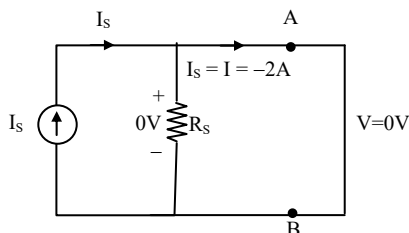

$\Rightarrow I_S = -2A$

Substituting I_S in eq (1)

$R_S = 10\Omega$

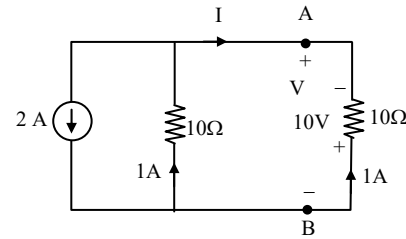

From the diagram;
 $I = -1A$ and $V = -10V$

06. Ans: (a)

Sol:

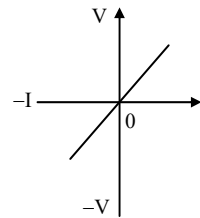

- * linear
- * Passive
- * bilateral

07. Ans: (b)

Sol:

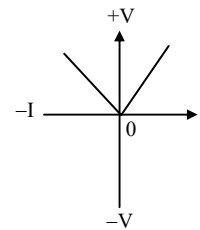

- * Non linear
- * Active
- * Unilateral

08. Ans: (e)

Sol:

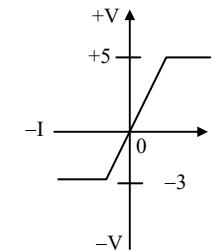

- * Non linear
- * Passive
- * Unilateral

09. Ans: (c)

Sol:

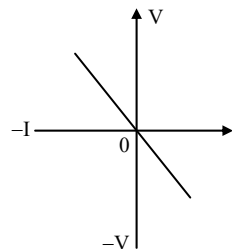

- * Linear
- * Active
- * Bilateral



10.
Sol:

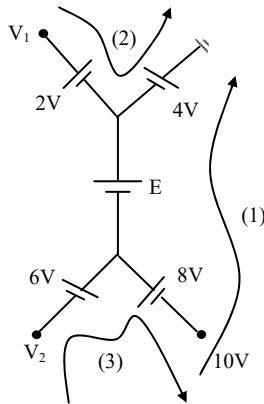

(1) By KVL $\Rightarrow +10 + 8 + E + 4 = 0$

$$E = -22V$$

(2) By KVL $\Rightarrow +V_1 - 2 + 4 = 0$

$$V_1 = -2V$$

(3) By KVL $\Rightarrow +V_2 + 6 - 8 - 10 = 0$

$$V_2 = 12V$$

11. Ans: (d)

Sol:

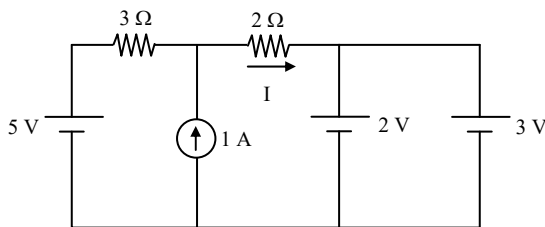

Here the 2V voltage source and 3V voltage source are in parallel which violates the KVL. Hence such circuit does not exist. (But practical voltage sources will have some internal resistance so that when two unequal voltage sources are connected in parallel current can flow and such a circuit may exist).

12. Ans: (d)

Sol:

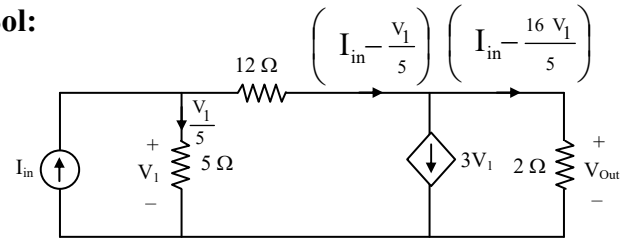

Applying KVL,

$$-V_1 + 12\left(I_{in} - \frac{V_1}{5}\right) + 2\left(I_{in} - \frac{16V_1}{5}\right) = 0$$

$$-V_1 + 12I_{in} - \frac{12V_1}{5} + 2I_{in} - \frac{32V_1}{5} = 0$$

$$14I_{in} = \frac{49}{5}V_1$$

$$\Rightarrow V_1 = \frac{70}{49}I_{in} \dots\dots\dots (1)$$

$$\therefore V_{out} = 2\left(I_{in} - \frac{16V_1}{5}\right) \dots\dots\dots (2)$$

Substitute equation (1) in equation (2)

$$V_{out} = 2\left(I_{in} - \frac{16}{5} \times \frac{70}{49}I_{in}\right)$$

$$= 2\left(\frac{-25}{7}\right)I_{in}$$

$$= \frac{-50}{7}I_{in}$$

$$\therefore V_{out} = -7.143 I_{in}$$

13. Ans: (c)

Sol:

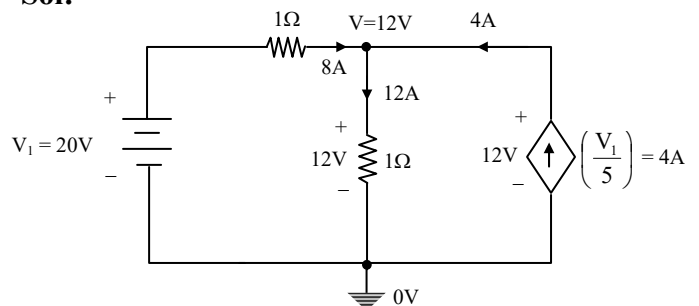



By nodal

$$\Rightarrow V - 20 + V - 4 = 0$$

$$V = 12 \text{ volts}$$

Power delivered by the dependent source is

$$P_{\text{del}} = (12 \times 4) = 48 \text{ watts}$$

14. Ans: (d)

Sol:

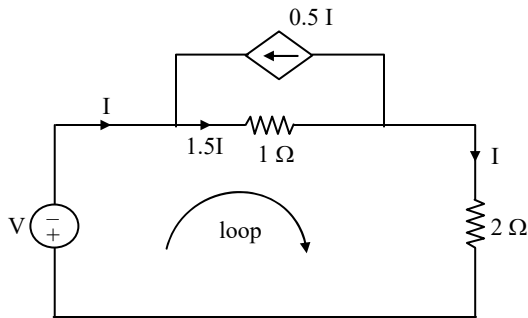
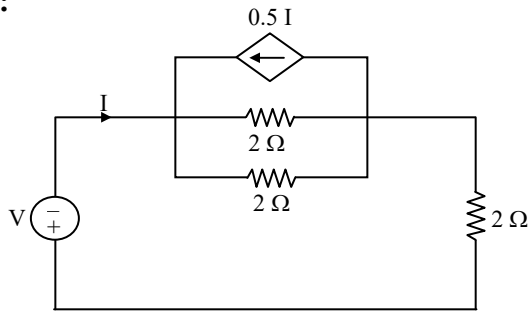

Applying KVL,

$$\Rightarrow V + 1.5I + 2I = 0$$

$$\Rightarrow V = -3.5 I$$

15. Ans: (c)

Sol:

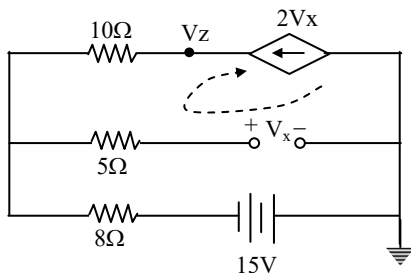

By using KCL

$$\frac{V_x + 15}{8} - 2V_x = 0$$

$$V_x = IV$$

By using nodal Analysis at V_z node

$$\frac{V_z + 15}{18} - 2 = 0$$

$$V_z = +21V$$

16. Ans: (a)

Sol: The given circuit is a bridge.

$I_R = 0$ is the bridge is balanced. i.e.,
 $Z_1 Z_4 = R_2 R_3$

Where $Z_1 = R_1 + j\omega L_1$,

$$Z_4 = R_4 - \frac{j}{\omega C_4}$$

As $R_2 R_3$ is real, imaginary part of
 $Z_1 Z_4 = 0$

$$\omega L_1 R_4 - \frac{R_1}{\omega C_4} = 0 \quad \text{or} \quad \frac{\omega L_1}{R_1} = \frac{1}{\omega C_4 R_4}$$

$$\text{or } Q_1 = Q_4$$

where Q is the Quality factor.

17.

Sol:

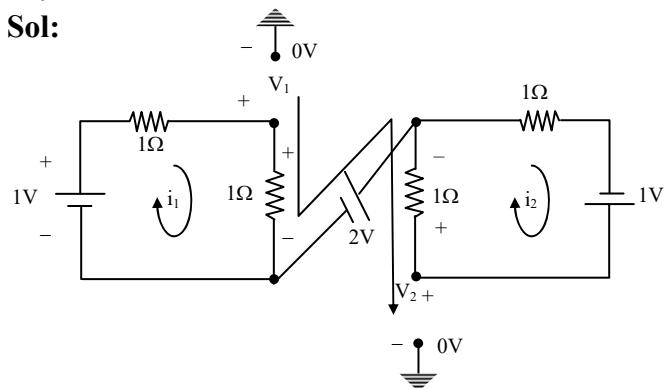

$$\text{By KVL} \Rightarrow 1 - i_1 - i_1 = 0$$

$$i_1 = 0.5A$$

$$\text{By KVL} \Rightarrow -i_2 - i_2 + 1 = 0$$

$$i_2 = 0.5A$$

$$\text{By KVL} \Rightarrow V_1 - 0.5 + 2 + 0.5 - V_2 = 0$$

$$V_2 = V_1 + 2V$$

18.

Sol: As the bridge is balanced; voltage across (G) is "0V".



By KCL at node "A" $\Rightarrow -I_s + 5m + 5m = 0$
 $I_s = 10mA$

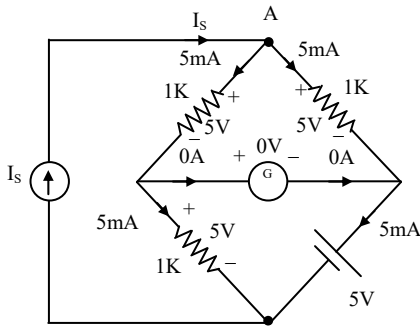

19.

Sol: Given data:

$V_R = 5V$ and $V_C = 4\sin 2t$ then $V_L = ?$

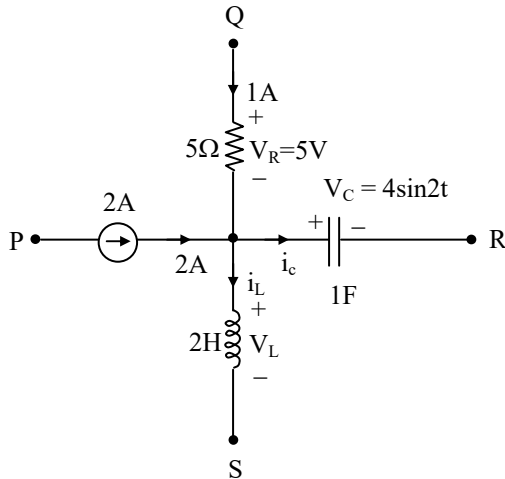

$$i_c = \frac{CdV_c}{dt} = \frac{d}{dt}(4\sin 2t) = 8\cos 2t$$

By KCL ; $-1 - 2 + i_L + i_c = 0$

$$i_L = 3 - 8\cos 2t$$

We know that;

$$V_L = L \frac{di_L}{dt} = 2 \frac{d}{dt}(3 - 8\cos 2t)$$

$$= 2(-8)(-2)\sin 2t$$

$$V_L = 32\sin 2t \text{ volt}$$

20.

Sol: $V = ?$ If power dissipated in 6Ω resistor is zero.

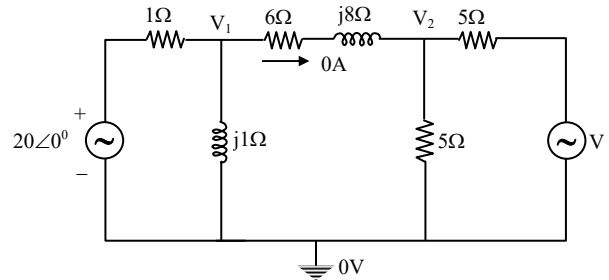

$P_{6\Omega} = 0 \text{ W (Given)}$

$$\Rightarrow i_{6\Omega}^2 \cdot 6 = 0$$

$$\Rightarrow i_{6\Omega} = 0 \text{ (} V_{6\Omega} = 0 \text{)}$$

$$\frac{V_1 - V_2}{6 + j8} = 0; V_1 = V_2$$

By Nodal

$$\Rightarrow \frac{V_1 - 20\angle 0^\circ}{1} + \frac{V_1}{j1} + 0 = 0$$

$$V_1 = 10\sqrt{2} \angle 45^\circ = V_2$$

By Nodal \Rightarrow

$$0 + \frac{V_2}{5} + \frac{V_2 - V}{5} = 0$$

$$V = 2V_2 = 2(10\sqrt{2} \angle 45^\circ)$$

$$\therefore V = 20\sqrt{2} \angle 45^\circ$$

21. Ans: (d)

Sol:

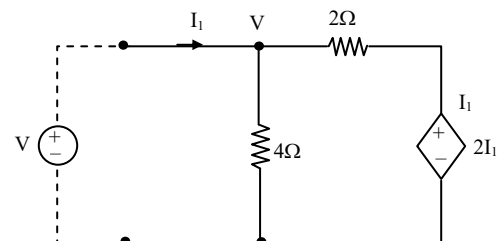

Note: Since no independent source in the network, the network is said to be unenergised, so called a DEAD network".



The behavior of this network is a load resistor behavior.

By Nodal \Rightarrow

$$-I_1 + \frac{V}{4} + \frac{V-2I_1}{2} = 0$$

$$3V = 8I_1$$

$$R_{eq} = \frac{V}{I_1} = \frac{8}{3} \Omega$$

22. Ans: (a)

Sol:

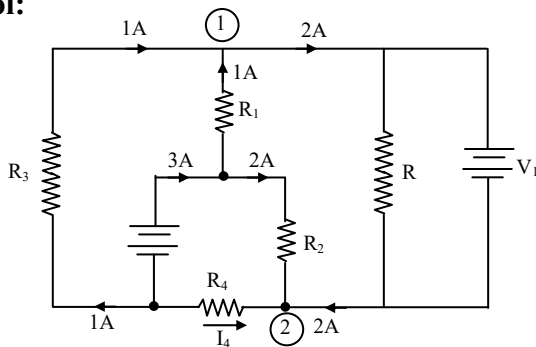

Apply KCL at Node - 1,

$$I = I_{R1} + I_{R3} = 1 + 1 = 2A$$

Apply KCL at Node - 2,

$$I_4 = -I_2 - I = -2 - 2 = -4A$$

23.

Sol:

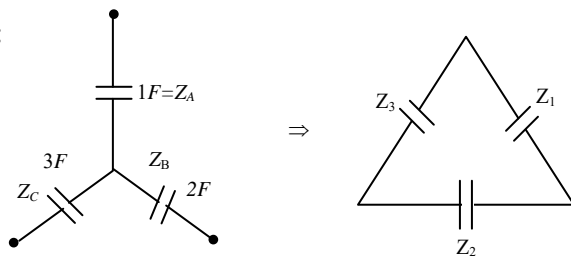
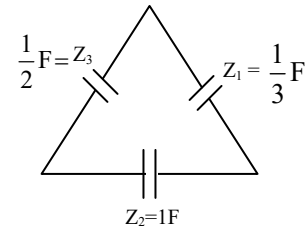

Fig.1

$$Z_1 = Z_A + Z_B + \left(\frac{Z_A Z_B}{Z_C} \right)$$

$$= \frac{1}{s} + \frac{1}{2s} + \left(\frac{1}{s} \right) \left(\frac{1}{2s} \right) \left(\frac{1}{3s} \right)$$

$$Z_1 = \frac{1}{s \left(\frac{1}{3} \right)} ; \quad C = \frac{1}{3} F$$



$$Z_2 = Z_B + Z_C + \frac{Z_B Z_C}{Z_A} = \frac{1}{2s} + \frac{1}{3s} + \left(\frac{1}{2s} \right) \left(\frac{1}{3s} \right) \left(\frac{1}{s} \right)$$

$$Z_2 = \frac{1}{s(1)} ; \quad C = 1F$$

$$Z_3 = Z_A + Z_C + \frac{Z_A Z_C}{Z_B} = \frac{1}{s} + \frac{1}{3s} + \left(\frac{1}{s} \right) \left(\frac{1}{3s} \right) \left(\frac{1}{2s} \right)$$

$$Z_3 = \frac{1}{s \left(\frac{1}{2} \right)} ; \quad C = \frac{1}{2} F$$

24.

Sol: $Z_{ab} = ?$

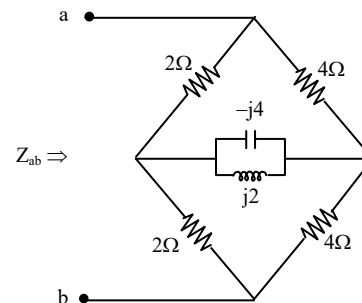

Since $2 * 4 = 4 * 2$; the given bridge is balanced one, therefore the current through the middle branch is zero. The bridge acts as below :

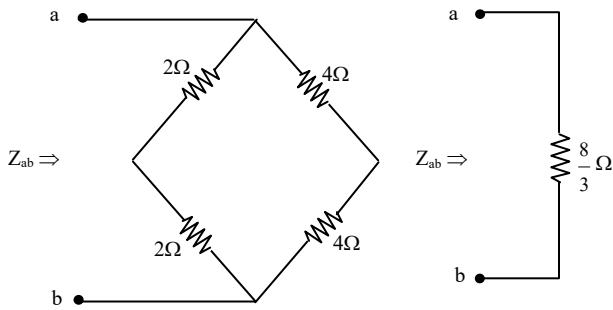

$$Z_{ab} = \frac{4 \times 8}{4 + 8} = \frac{8}{3} \Omega$$

25.

Sol: Redraw the circuit diagram as shown below:

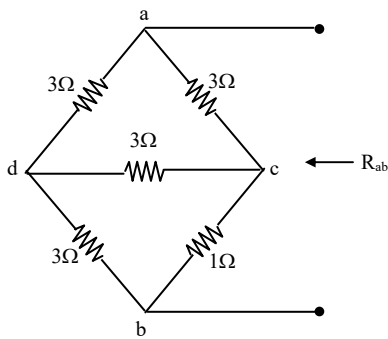

Using Δ to star transformation:

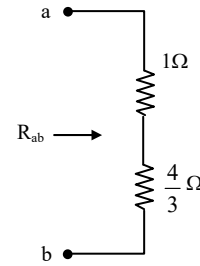
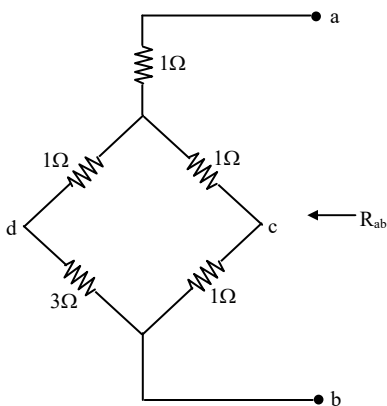

$$\therefore R_{ab} = 1 + \frac{4}{3} = \frac{7}{3} \Omega$$

26.

Sol: On redrawing the circuit diagram

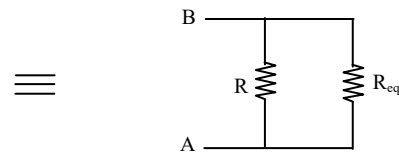
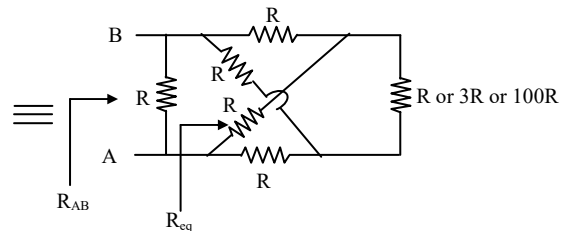
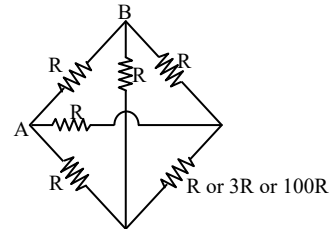

$$\text{So } R_{AB} = R \parallel R_{eq} = R \parallel R = R/2$$

27. Ans: (b)

Sol: The equivalent capacitance across a, b is calculated by simplifying the bridge circuit as shown in Fig. 1 to Fig. 5. [$\because C = 0.1\mu\text{F}$]

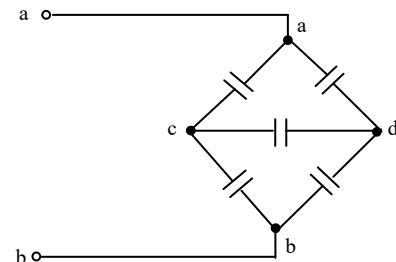
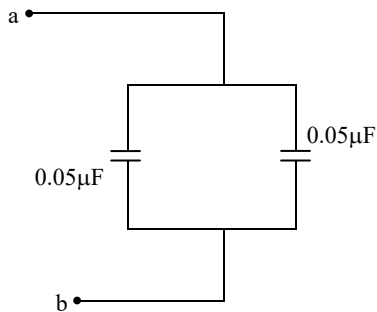
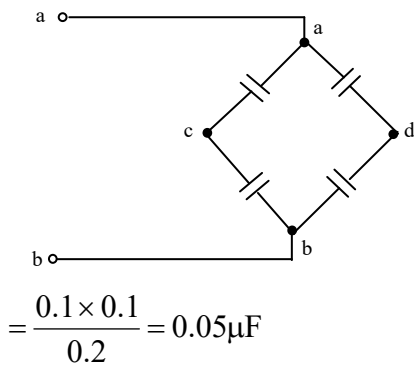

Fig. 1



$C_{ab} = 0.1 \mu\text{F}$

Note: The bridge is balanced and the answer is easy to get.

28. Ans: (a)

Sol: Consider a Δ connected network

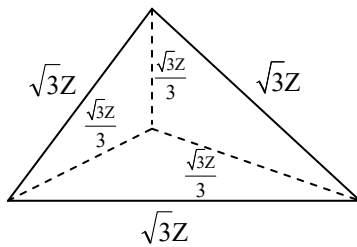

Then each branch of the equivalent λ connected impedance is $\frac{\sqrt{3}Z}{3} = \frac{Z}{\sqrt{3}}$

29. Ans: (a)

Sol: Network is redrawn as

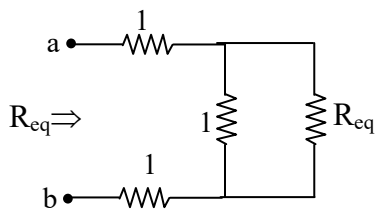

$$R_{eq} = 1 + 1 + \frac{R_{eq}}{1 + R_{eq}}$$

$$= 2 + \frac{R_{eq}}{1 + R_{eq}} = \frac{2 + 2R_{eq} + R_{eq}}{1 + R_{eq}}$$

$$R_{eq} + R_{eq}^2 = 2 + 3R_{eq}$$

$$R_{eq}^2 - 2R_{eq} - 2 = 0$$

$$R_{eq} = (1 + \sqrt{3}) \Omega$$

30. Ans: (c)

Sol: Applying KCL

$$I_{0.25\Omega} = 2i + i = 3i$$

$$I_{0.125\Omega} = (1 - 3i) \text{ A}$$

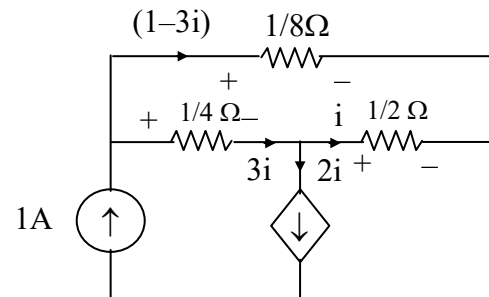

Applying KVL in upper loop.

$$-\frac{(1-3i)}{8} + \frac{i}{2} + \frac{3i}{4} = 0$$

$$\frac{5i}{4} = \frac{1-3i}{8}$$

$$10i = 1-3i$$

$$\therefore i = \frac{1}{13} \text{ A}$$

$$V = \frac{3i}{4} = \frac{3}{4} \times \frac{1}{13} = \frac{3}{52} \text{ V}$$



31. Ans: (a)

Sol:

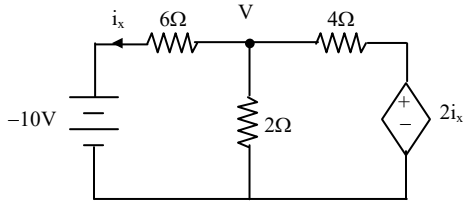

Applying KCL at Node V

$$\frac{V}{2} + \frac{V - 2i_x}{4} + i_x = 0 \dots\dots\dots (1)$$

$$i_x = \frac{V + 10}{6} \Rightarrow V = 6i_x - 10$$

Put in equation (1), we get

$$3i_x - 5 + i_x - 2.5i_x = 0$$

$$5i_x = 7.5$$

$$i_x = 1.5A$$

$$V = -1V$$

$$I_{\text{dependent source}} = \frac{V - 2i_x}{4} = \frac{-1 - 3}{4} = -1A$$

$$\begin{aligned} \therefore \text{Power absorbed} &= (I_{\text{dependent source}}) (2i_x) \\ &= (-1) (3) \\ &= -3W \end{aligned}$$

32. Ans: (d)

Sol: $V_0 = ?$

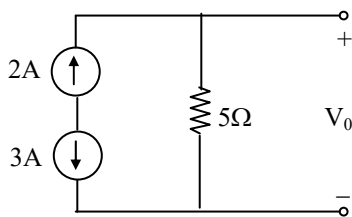

$$\begin{aligned} \text{By KCL} \Rightarrow \quad &+2 + 3 = 0 \\ &+5 \neq 0 \end{aligned}$$

Since the violation of KCL in the circuit; physical connection is not possible and the circuit does not exist.

33. Ans: (b)

Sol: Redraw the given circuit as shown below:

By KVL \Rightarrow

$$-15 - V_0 = 0$$

$$V_0 = -15V$$

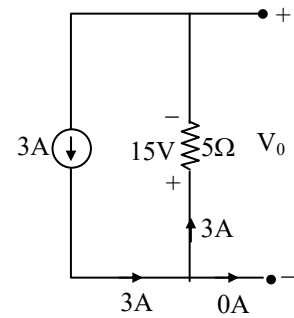

34. Ans: (d)

Sol: Redraw the circuit diagram as shown below:

Across any element two different voltages at a time is impossible and hence the circuit does not exist.

Another method:

By KVL \Rightarrow

$$5 + 10 = 0$$

$$15 \neq 0$$

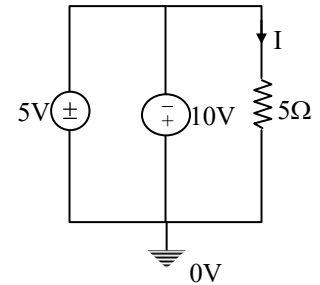

Since the violation of KVL in the circuit, the physical connection is not possible.

35. Ans: (d)

Sol: Redraw the given circuit as shown below:

By KVL \Rightarrow

$$-10 - 10 = 0$$

$$-20 \neq 0$$

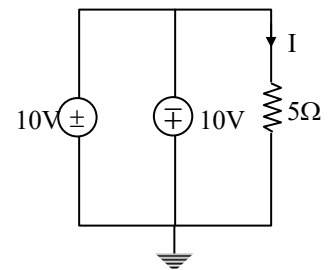

Since the violation of KVL in the circuit, the physical connection is not possible.



36. Ans: (b)

Sol: Redraw the given circuit as shown below:

By KVL \Rightarrow

$$10 - 10 = 0$$

$$0 = 0$$

KVL is satisfied

$$I_{5\Omega} = \frac{10}{5} = 2A$$

$$I_{5\Omega} = 2A$$

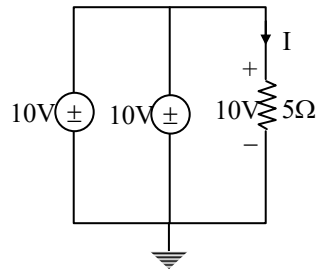

37. Ans: (d)

Sol:

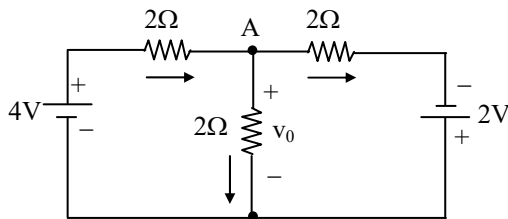

Fig. 1

The diode is forward biased. Assuming that the diode is ideal, the Network is redrawn with node A marked as in Fig. 1.

Apply KCL at node A

$$\frac{4 - v_0}{2} = \frac{v_0}{2} + \frac{v_0 + 2}{2}$$

$$\frac{3v_0}{2} = 1$$

$$v_0 = \frac{2}{3}V$$

Here polarity is different what we assume so

$$V_0 = -\frac{2}{3}V$$

38.

Sol: (in the question 4V voltage source polarity is reversed)

The actual circuit is

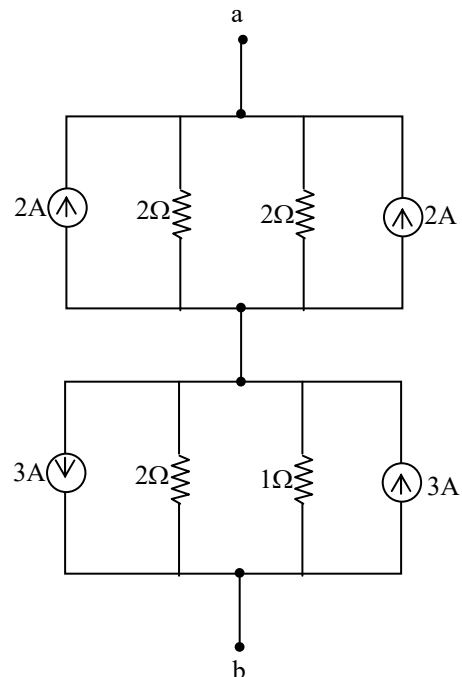
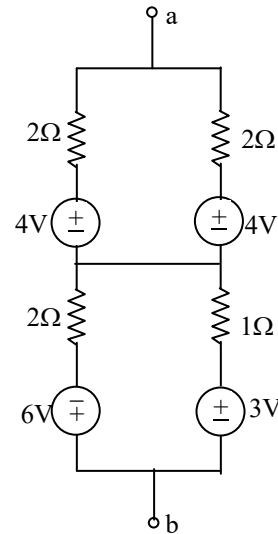

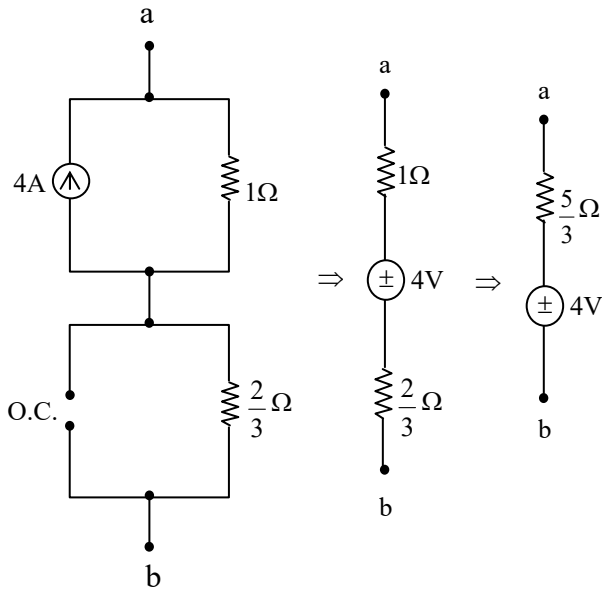

39. Ans: (b)

Sol:

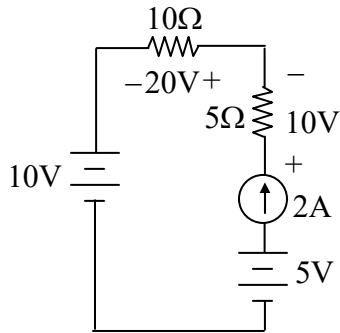

$$\text{Voltage across } 2A = 10 + 20 + 10 - 5 = 35 \text{ V}$$

$$\begin{aligned} \therefore \text{Power supplied} &= VI \\ &= 35 \times 2 \\ &= 70 \text{ W} \end{aligned}$$

40. Ans: 4 Volts

Sol:

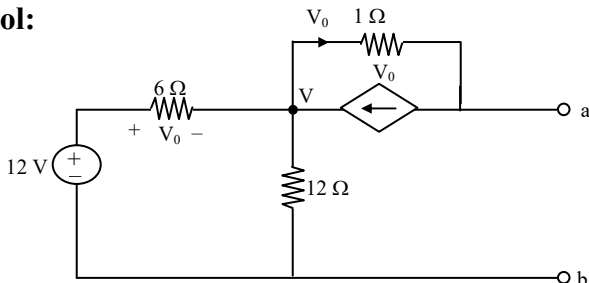

Applying KCL at node V

$$\frac{V-12}{6} + \frac{V}{12} - V_0 + V_0 = 0$$

$$\Rightarrow \frac{V}{6} + \frac{V}{12} = 2$$

$$V = 8 \text{ V}$$

$$\therefore V_0 = 4 \text{ V}$$

Applying KVL in outer loop

$$\Rightarrow -V + 1(V_0) + V_{ab} = 0$$

$$\Rightarrow V_{ab} = V - V_0 = 8 - 4 = 4 \text{ V}$$

41. Ans: $V_i = 16 \text{ V}$ & $P_{\text{del}} = P_{\text{abs}} = 48 \text{ W}$

Sol: By KVL

$$\Rightarrow V_i - 6 - 10 = 0$$

$$V_i = 16 \text{ V}$$

$$P_{4\Omega} = (8 * 2) = 16 \text{ watts} - \text{absorbed}$$

$$P_{2A} = (24 * 2) = 48 \text{ watts delivered}$$

$$P_{3\Omega} = (6 * 2) = 12 \text{ watts} - \text{absorbed}$$

$$P_{10V} = (10 * 2) = 20 \text{ watts} - \text{absorbed}$$

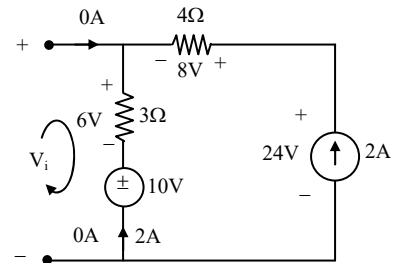

Since; $P_{\text{del}} = P_{\text{abs}} = 48 \text{ watts}$. Tellegen's Theorem is satisfied.

42. Ans: $V_x = 12 \text{ V}$ & $P_{\text{del}} = P_{\text{abs}} = 144 \text{ W}$

Sol: By KVL in first mesh

$$\Rightarrow V_x - 6 + 6 - 12 = 0$$

$$V_x = 12 \text{ V}$$

$$P_{12V} = (12 \times 9) = 108 \text{ watts delivered}$$

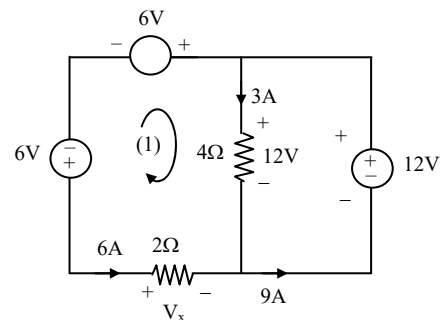



$P_{4\Omega} = (12 \times 3) = 36$ watts – absorbed
 $P_{6V} = (6 \times 6) = 36$ watts – absorbed
 $P_{6V} = (6 \times 6) = 36$ watts – delivered
 $P_{2\Omega} = (12 \times 6) = 72$ watts – absorbed
 Since $P_{del} = P_{abs}$; Tellegen's theorem is satisfied.

43. Ans: $I = \frac{60}{17}$ A & $P_{del} = P_{abs} = 89.58$ W

Sol:

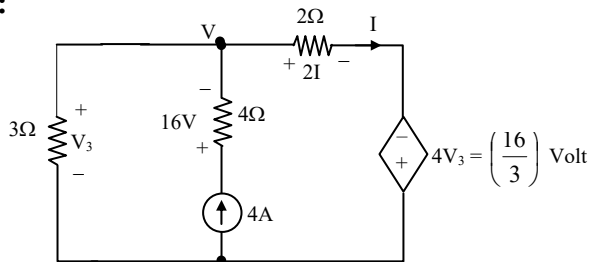

By Nodal \Rightarrow

$$\frac{V}{3} - 4 + \frac{V}{2} + \frac{4V_3}{2} = 0$$

$$\frac{5V}{6} = 4 - 2V_3 \dots\dots\dots (1)$$

By KVL \Rightarrow
 $V_3 - 2I + 4V_3 = 0$

$$5V_3 - 2I = 0 \dots\dots\dots (2)$$

By KVL \Rightarrow
 $V = V_3 \dots\dots\dots (3)$

Substitute (3) in (1), we get

$$V_3 = \frac{24}{17}$$

$$V_3 = \frac{24}{17} \text{ Volt and } I = \frac{60}{17} \text{ A}$$

$$P_{3\Omega} = 0.663 \text{ W absorbed}$$

$$P_{4\Omega} = 64 \text{ W absorbed}$$

$$P_{4A} = 69.64 \text{ W delivered}$$

$$P_{2\Omega} = 24.91 \text{ W absorbed}$$

$$P_{4V_3} = 19.92 \text{ W delivered}$$

Since $P_{del} = P_{abs} = 89.57$ W; Tellegen's Theorem is satisfied.

Chapter 2

Circuit Theorems

Class Room Practice Solutions

01.

Sol: The current "I" = ?

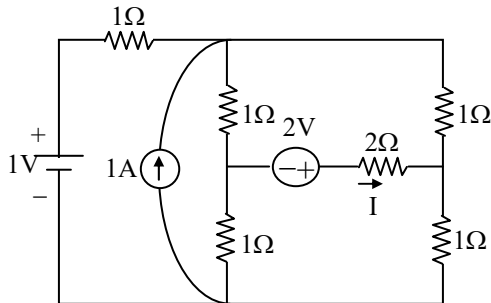

By superposition theorem, treating one independent source at a time.

(a) When 1A current source is acting alone.

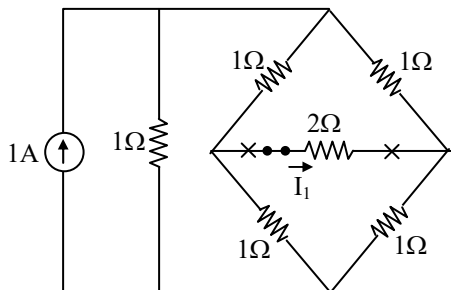

Since the bridge is balanced ; $I_1 = 0A$

(b) When 1V voltage source is acting alone

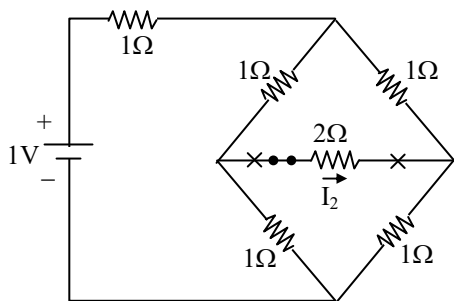

$$I_2 = 0A$$

Since the bridge is balanced.

(c) When 2V voltage source is acting alone

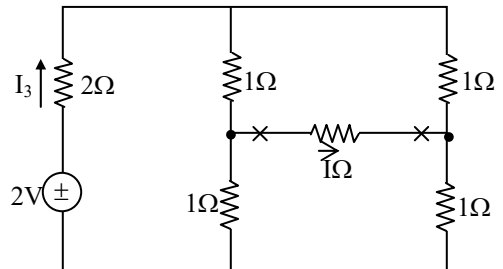

$$I_3 = \frac{2}{3} = 0.66A$$

By superposition theorem ; $I = I_1 + I_2 + I_3$

$$I = 0 + 0 + 0.66A$$

$$I = 0.66A$$

02.

Sol:

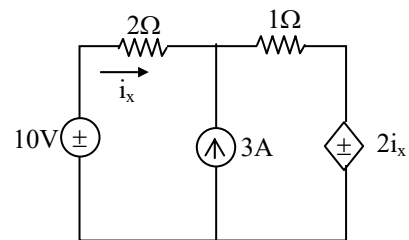

$$i_x = ?$$

By super position theorem ; treating only one independent source at a time

(a) When 10V voltage source is acting alone

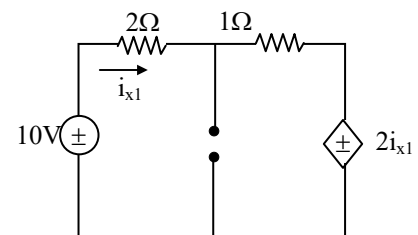



By KVL \Rightarrow
 $10 - 2i_{x1} - i_{x1} - 2i_{x1} = 0$
 $i_{x1} = 2A$

(b) When 3A current source is acting alone

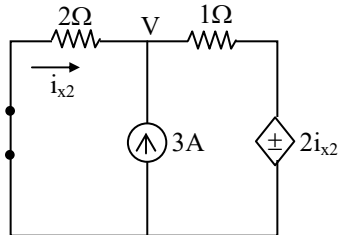

By Nodal \Rightarrow
 $\frac{V}{2} - 3 + \frac{(V - 2i_{x2})}{1} = 0$
 $3V - 4i_{x2} = 6 \dots\dots\dots (1)$

And
 $i_{x2} = \frac{0 - V}{2} \Rightarrow V = -2i_{x2} \dots\dots(2)$

Put (2) in (1), we get

$i_{x2} = -\frac{3}{5}A$

By SPT ;

$i_x = i_{x1} + i_{x2} = 2 - \frac{3}{5} = \frac{7}{5}$

$\therefore i_x = 1.4A$

03. Sol:

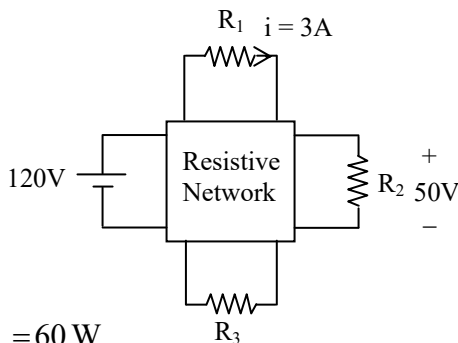

$P_{R_3} = 60W$

For 120 V $\rightarrow i_1 = 3A$

For 105 V $\rightarrow i_1 = \frac{105}{120} \times 3 = 2.625A$

For 120 V $\rightarrow V_2 = 50V$

For 105 V $\rightarrow V_2 = \frac{105}{120} \times 50 = 43.75V$

$V_2 = 120V \Rightarrow I^2 R_3 = 60W \Rightarrow I = \sqrt{\frac{60}{R_3}}$

For $V_s = 105V$

$P_3 = \left(\frac{105}{120} \sqrt{\frac{60}{R_3}} \right)^2 \times R_3 = 45.9W$

04. Ans: (b)

Sol: It is a linear network

$\therefore V_x$ can be assumed as function of i_{s1} and i_{s2}

$V_x = Ai_{s1} + Bi_{s2}$

$80 = 8A + 12B \rightarrow (1)$

$0 = -8A + 4B \rightarrow (2)$

From equation 1 & 2

$A = 2.5; B = 5$

Now, $V_x = (2.5)(20) + (5)(20)$

$V_x = 150V$

05. Ans: (c)

Sol:

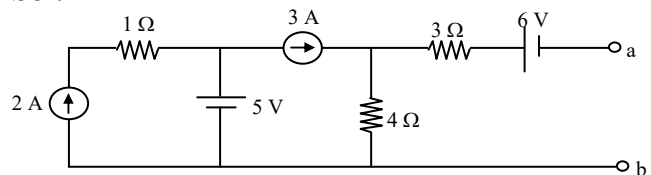

For finding Norton's equivalent resistance independent voltage sources to be short circuited and independent current sources to be open circuited, then the above circuit becomes

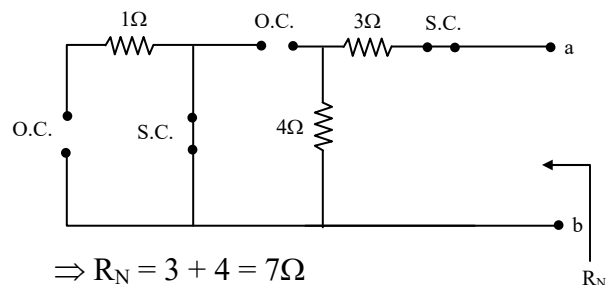

$\Rightarrow R_N = 3 + 4 = 7\Omega$



06. Ans: (b)

Sol:

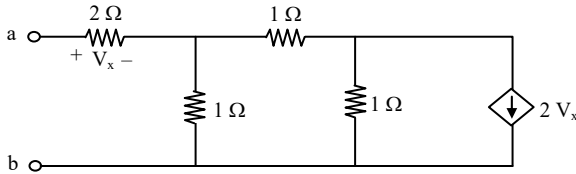

Excite with a voltage source 'V'

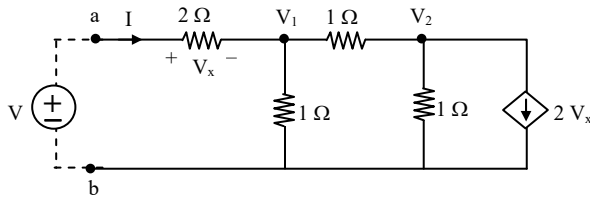

Apply KCL at node V_1

$$-I + \frac{V_1}{1} + \frac{V_1 - V_2}{1}$$

$$\Rightarrow 2V_1 - V_2 - I = 0 \dots\dots(1)$$

Apply KCL at node V_2

$$\frac{V_2 - V_1}{1} + \frac{V_2}{1} + 2V_x = 0$$

$$2V_2 - V_1 + 2V_x = 0 \dots\dots (2)$$

But from the circuit,

$$V_x = 2I \dots\dots (3)$$

Substitute (3) in (2)

$$\Rightarrow 2V_2 - V_1 + 4I = 0$$

$$4V_2 - 2V_1 + 8I = 0$$

From (1),

$$2V_1 = V_2 + I$$

$$\therefore 4V_2 - (V_2 + I) + 8I = 0$$

$$\Rightarrow 3V_2 + 7I = 0$$

$$\Rightarrow V_2 = -\frac{7I}{3}$$

Substitute (2) in (1)

$$2V_1 - \left(-\frac{7I}{3}\right) - I = 0$$

$$2V_1 + \frac{7}{3}I - I = 0 \Rightarrow 2V_1 = \frac{-4I}{3}$$

$$\Rightarrow V_1 = \frac{-2I}{3}$$

$$\therefore V = V_x + V_1 = 2I + \left(-\frac{2I}{3}\right)$$

$$= \frac{4I}{3}$$

$$\Rightarrow V = \frac{4I}{3}$$

$$\Rightarrow \frac{V}{I} = \frac{4}{3}\Omega \Rightarrow R_{cq} = \frac{4}{3}\Omega$$

07.

Sol:

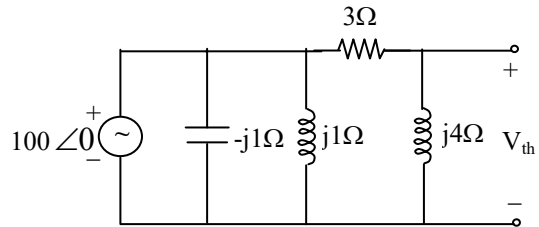

Here $j1\Omega$ and $-j1\Omega$ combination will act as open circuit.

The circuit becomes

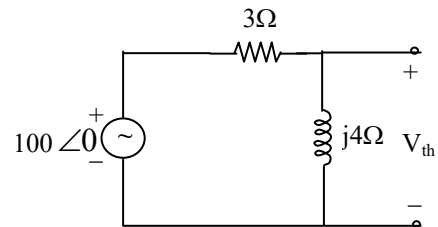

$$\Rightarrow V_{th} = \frac{100\angle 0^\circ \times j4}{3 + j4}$$

$$= 80\angle 36.86^\circ \text{ V}$$

08. Ans: $V_{th} = 150 \text{ V}$, $I_{sc} = \frac{15}{2} \text{ A}$, $R_{th} = R_N = 20\Omega$

Sol: Thevenin's and Norton's equivalents across a, b.

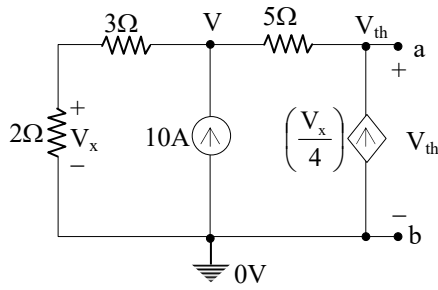

By Nodal \Rightarrow

$$\frac{V}{5} - 10 + \frac{V}{5} - \frac{V_{th}}{5} = 0$$

$$\frac{V_{th}}{5} - \frac{V}{5} - \frac{V_x}{4} = 0$$

$$\frac{2V}{5} = \left(10 + \frac{V_{th}}{5}\right)$$

$$\frac{V_{th}}{5} = \left(\frac{V}{10} + \frac{V}{5}\right)$$

$$V_x = \left(\frac{2V}{5}\right)$$

$$V_{th} = 150V, V = 100V$$

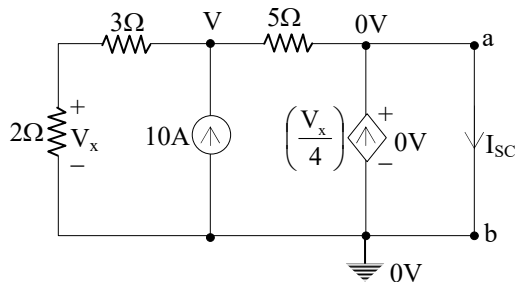

$$\frac{V}{5} - 10 + \frac{V}{5} = 0$$

$$\frac{2V}{5} = 10$$

$$V = 25V$$

$$V_x = \frac{2V}{5} = \frac{2 \times 25}{5}$$

$$V_x = 10V$$

$$I_{sc} = \left(\frac{10}{4} + 5\right) = \frac{15}{2} A$$

$$I_{sc} = \frac{15}{2} A$$

$$R_{th} = \frac{V_{th}}{I_{sc}} = \frac{150}{\frac{15}{2}} = 20\Omega$$

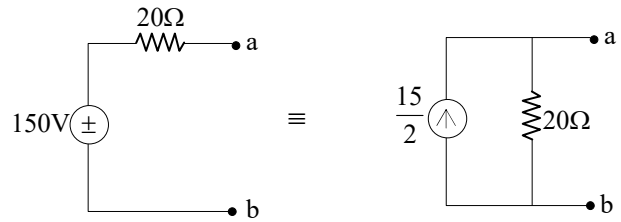

09. Ans: 50.5 Ω

Sol:

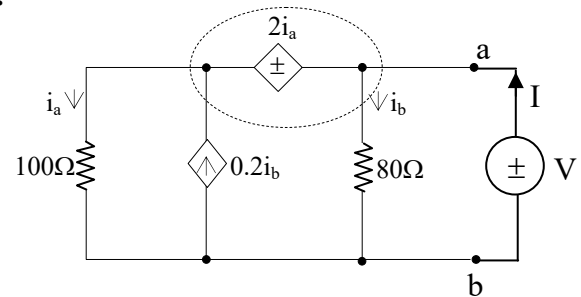

Super nodal equation

$$\Rightarrow i_a - 0.2i_b + i_b - I = 0$$

$$I = i_a + 0.8i_b$$

$$V = 80i_b ; i_b = \frac{V}{80}$$

- Inside the super node, always the KVL is written.

By KVL \Rightarrow

$$100i_a + 2i_a - 80i_b = 0$$

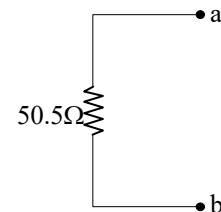

$$I = \frac{V}{102} + \frac{0.8 \times V}{80}$$

$$\frac{V}{I} = R_L = \frac{1}{\frac{1}{102} + \frac{1}{100}} = 50.5\Omega.$$

$$R_L = 50.5\Omega$$



10. Ans: 625 W

Sol: V_{th} :

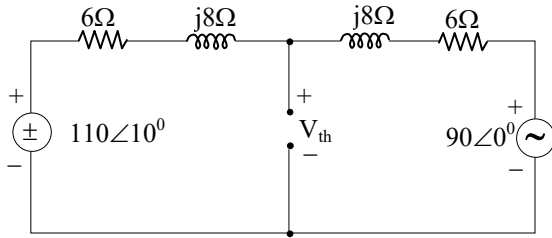

By Nodal \Rightarrow

$$\frac{V_{th}}{(6 + j8)} - \frac{110\angle 0^\circ}{(6 + j8)} + \frac{V_{th}}{(6 + j8)} - \frac{90\angle 0^\circ}{(6 + j8)} = 0$$

$$2V_{th} = 200\angle 0^\circ \Rightarrow V_{th} = 100\angle 0^\circ.$$

R_{th} :

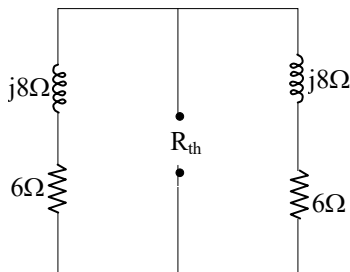

$$R_{th} = (6 + j8) \parallel (6 + j8) \equiv (3 + j4)\Omega$$

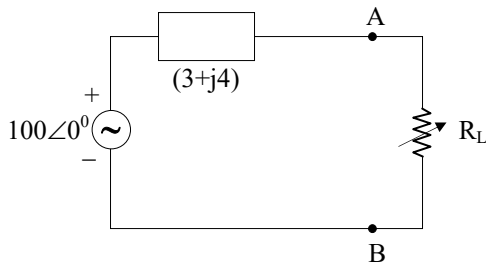

$$R_L = |3 + j4| = 5\Omega$$

$$I = \frac{100\angle 0^\circ}{(8 + j4)}$$

$$P = |I|^2 \times R_L$$

$$P_{max} = 125 \times 5 = 625 \text{ W}$$

$$\therefore P_{max} = 625 \text{ Watts}$$

11. Ans: 236 W

Sol:

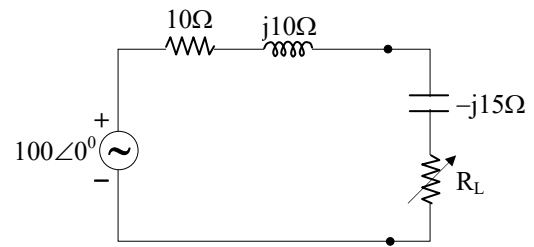

The maximum power delivered to “ R_L ” is

$$R_L = \sqrt{R_s^2 + (X_s + X_L)^2}$$

Here $R_s = 10\Omega$; $X_s = 10\Omega$ & $X_L = -15$

$$R_L = \sqrt{10^2 + (10 - 15)^2}$$

$$R_L = 5\sqrt{5}\Omega.$$

$$I = \frac{100\angle 0^\circ}{(10 + j10 - j15 + 5\sqrt{5})}$$

$$P_{max} = |I|^2 \cdot 5\sqrt{5} = 236 \text{ W}$$

12. Ans: 250 W

Sol:

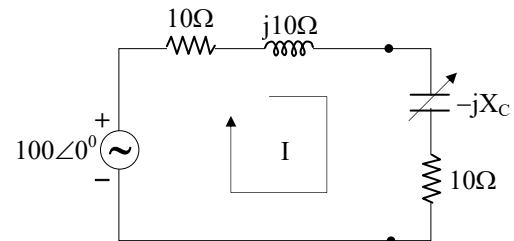

The maximum power delivered to 10Ω load resistor is:

$$Z_L = 10 - jX_C = 10 + j(-X_C)$$

$$X_L = -X_C$$

So for MPT ; $(X_s + X_L) = 0$

$$10 - X_C = 0;$$

$$X_C = 10$$

$$I = \frac{100\angle 0^\circ}{(10 + j10 - j10 + 10)} = 5\angle 0^\circ$$

$$P_{max} = |I|^2 R_L = 5^2(10) = 250 \text{ W}$$

$$P_{max} = 250 \text{ Watts}$$



13. Ans: (b)

Sol:

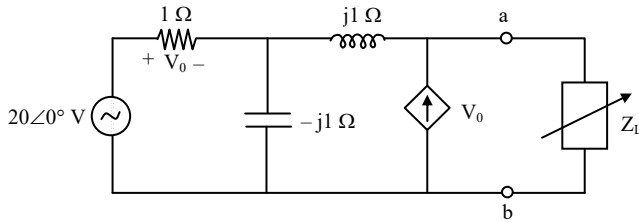

For maximum power delivered to Z_L ,

$$Z_L = Z_{th}^*$$

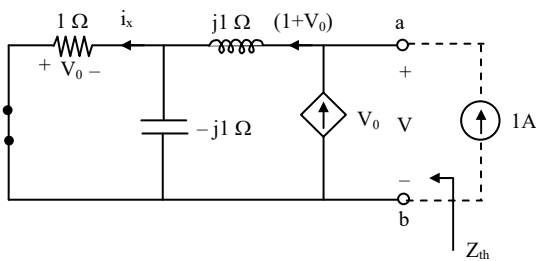

$$i_x = (1 + V_0) \times \frac{-j1}{1 - j1} = (1 + V_0) (0.5 - j0.5)$$

But

$$\begin{aligned} V_0 &= -i_x \\ &= -(1 + V_0) (0.5 - j0.5) \\ (-1 - j) V_0 &= 1 + V_0 \\ \Rightarrow V_0 (-1 - j - 1) &= 1 \\ V_0 &= \frac{1}{-2 - j} = -0.4 + j0.2 \end{aligned}$$

Applying KVL

$$\begin{aligned} +V_0 - j1(1 + V_0) + V &= 0 \\ \Rightarrow V &= -V_0 + j1(1 + V_0) \\ &= 0.4 - j0.2 + j1(0.6 + j0.2) \\ V &= (0.2 + j0.4) \text{ V} \\ \therefore Z_{th} &= \frac{V}{1} = V = (0.2 + j0.4) \Omega \\ \therefore Z_L = Z_{th}^* &= (0.2 - j0.4) \Omega \end{aligned}$$

14. Ans: 250 W

Sol:

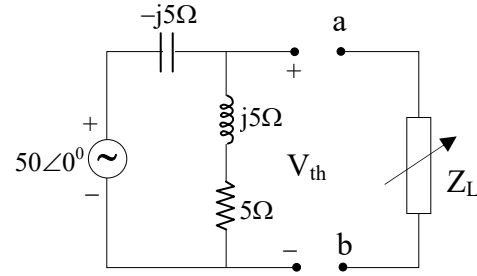

The maximum true power delivered to “ Z_L ” is :

$$V_{th} = \left(\frac{50 \angle 0^\circ}{-j5 + j5 + 5} \right) (j5 + 5) = 50 \sqrt{2} \angle 45^\circ$$

$$Z_{th} = (-j5) \parallel (5 + j5) = (5 - j5) \Omega$$

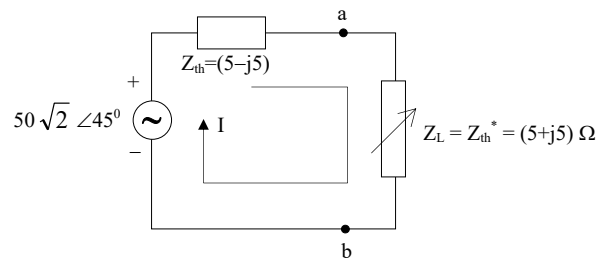

$$I = \frac{50 \sqrt{2} \angle 45^\circ}{(5 - j5 + 5 + j5)} = 5 \sqrt{2} \angle 45^\circ$$

$$P = |I|^2 5 = |5 \sqrt{2}|^2 \cdot 5$$

$$= 250 \text{ Watts}$$

$$\therefore P_{max} = 250 \text{ Watts}$$

15. Ans: (c)

Sol:

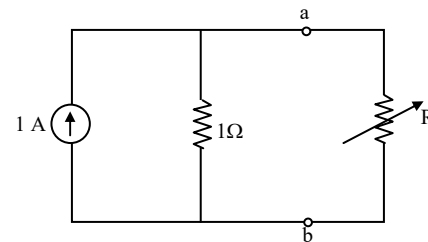

Maximum power will occur when $R = R_s$

$$\Rightarrow R = 1 \Omega$$

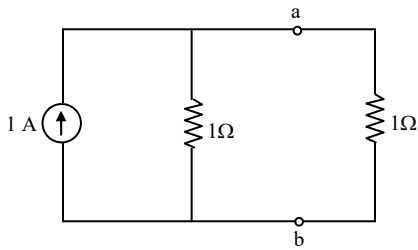

$$\therefore P_{\max} = \left(\frac{1}{2}\right)^2 \times 1 = \frac{1}{4} \text{ W}$$

$$25\% \text{ of } P_{\max} = \frac{1}{4} \times \frac{1}{4} = \frac{1}{16} \text{ W}$$

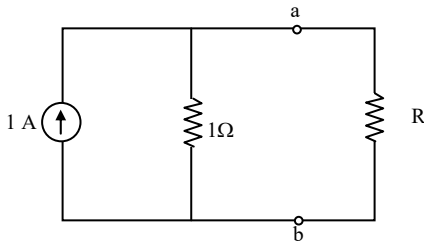

current passing through 'R'

$$I = 1 \times \frac{1}{1+R} = \frac{1}{1+R}$$

$$\therefore P = I^2 R = \left(\frac{1}{1+R}\right)^2 R = \frac{1}{16}$$

$$\Rightarrow (R+1)^2 = 16R$$

$$\Rightarrow R^2 + 2R + 1 = 16R$$

$$\Rightarrow R^2 - 14R + 1 = 0$$

$$R = 13.9282\Omega \text{ or } 0.072\Omega$$

From the given options 72mΩ is correct

16. Ans: 20 V

Sol: For, $E = 1\text{V}$, $I = 0\text{A}$ then $V = 3\text{V}$

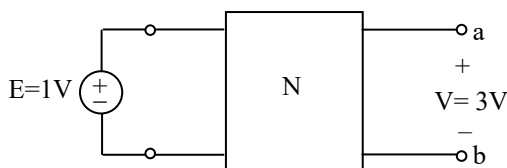

Fig.(b)

$V_{oc} = 3\text{V}$ (with respect to terminals a and b)
For, $E = 0\text{V}$, $I = 2\text{A}$ then $V = 2\text{V}$

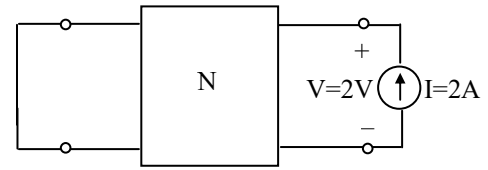
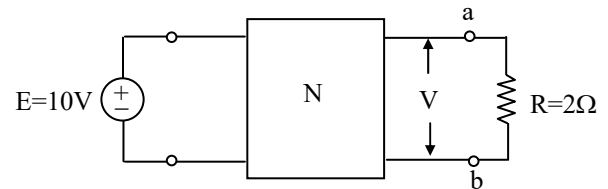

Fig.(c)

Now when $E = 10\text{V}$, and I is replaced by $R = 2\Omega$ then $V = ?$



When $E = 10\text{V}$,

From Fig.(b) using homogeneity principle

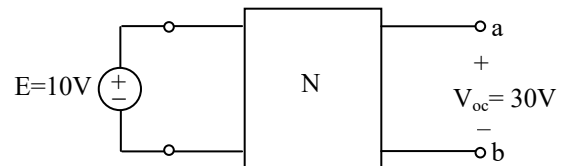

For finding thevenin's resistance across ab independent voltage sources to be short circuited & independent current sources to be open circuited.

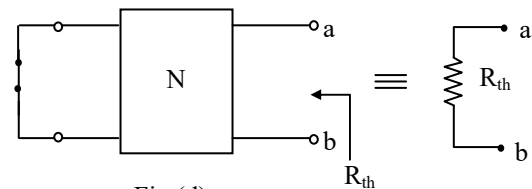
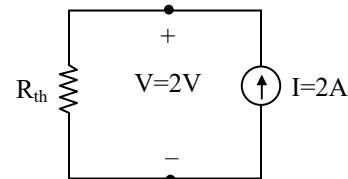

Fig.(d)

Fig.(c) is the energized version of Fig.(d)



$$\Rightarrow R_{th} = \frac{2}{2} = 1\Omega$$



∴ with respect to terminals a and b the Thevenin's equivalent becomes.

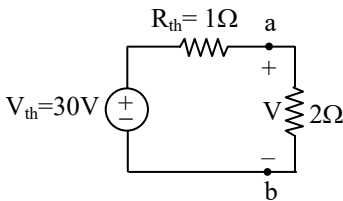
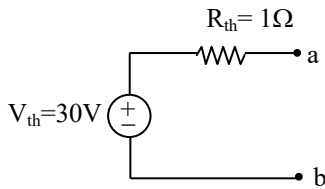

$$V = 30 \times \frac{2}{2+1} = 20V$$

$$\therefore V = 20V$$

17. Ans: 4 A

Sol: Superposition theorem cannot be applied to fig (b)

Since there is only voltage source given:

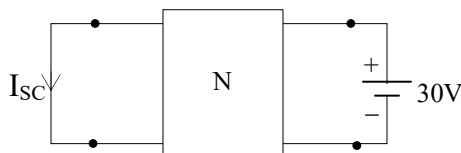
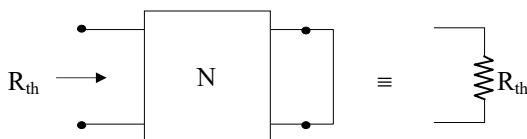

Fig (c)

By homogeneity and Reciprocity principles to fig (a);

$$I_{sc} = 6A$$

For R_{th} :



Statement: Fig (a) is the energized version of figure (d)

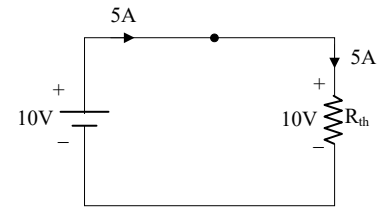

Fig (a)

$$10 = R_{th} \cdot 5 \quad \text{by ohm's law}$$

$$R_{th} = 2\Omega.$$

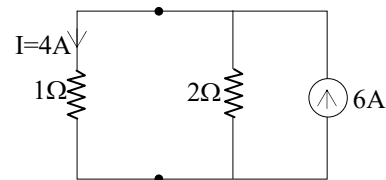

Fig (b)

$$I = \frac{6 \times 2}{(2+1)} = 4A$$

$$I = 4A$$

18. Ans: (b)

Sol:

$$\begin{bmatrix} 10 \\ 4 \end{bmatrix} = \begin{bmatrix} Z_{11} & Z_{12} \\ Z_{21} & Z_{22} \end{bmatrix} \begin{bmatrix} 4 \\ 0 \end{bmatrix}$$

$$10 = Z_{11} (4) + Z_{12} (0)$$

$$4 = Z_{21} (4) + Z_{22} (0)$$

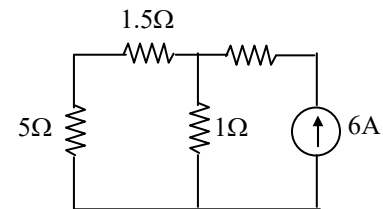

$$Z_{11} = \frac{10}{4} = 2.5$$

$$Z_{21} = \frac{4}{4} = 1$$

$$I_{5\Omega} = \frac{6 \times 1}{6.5 + 1} = \frac{6}{7.5} = 0.8A$$



19. Ans: (b)

Sol:

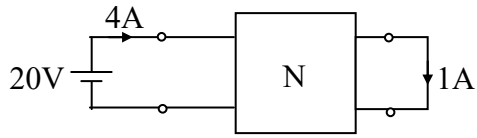

Fig.(a)

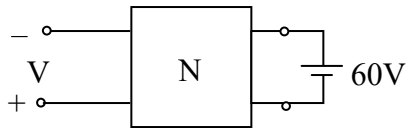

Fig.(b)

Using reciprocity theorem, for Fig.(a)

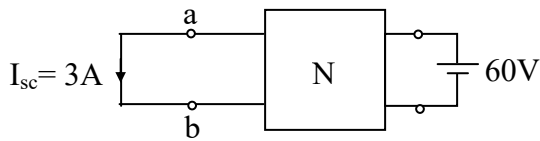
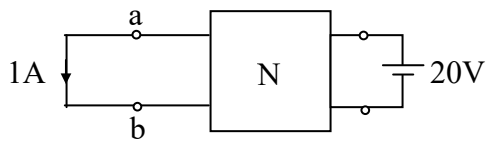

Fig.(c)

Norton's resistance between a and b is

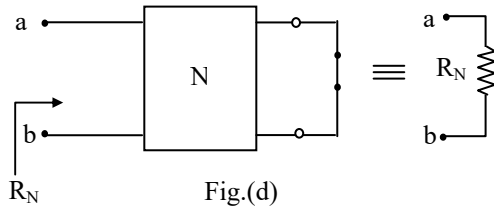
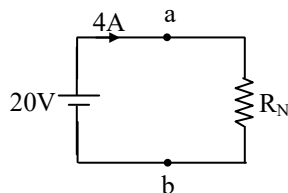

Fig.(d)

Fig.(a) is the energized version of Fig.(d)



$$\Rightarrow R_N = \frac{20}{4} = 5\Omega$$

With respect to terminals a and b the Norton's equivalent of Fig.(b) is

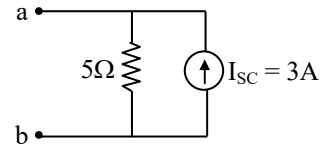

∴ From Fig.(b)

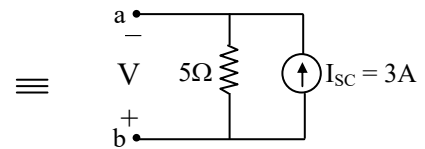
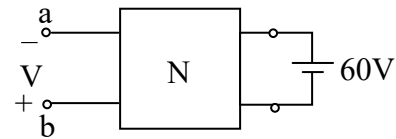

$$\Rightarrow V = -15V$$

20.

Sol:

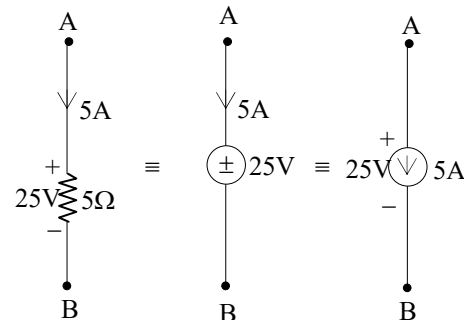
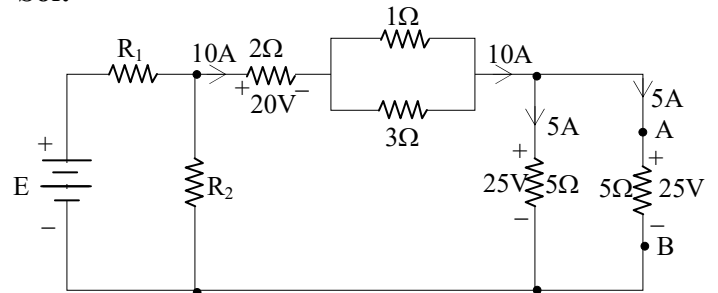

$$P_{AB} = P_{5\Omega} = P_{25V} = P_{5A} = 5 \times 25 = 125 \text{ watts (ABSORBED)}$$



21. Ans: $-\frac{2}{7}A$

Sol:

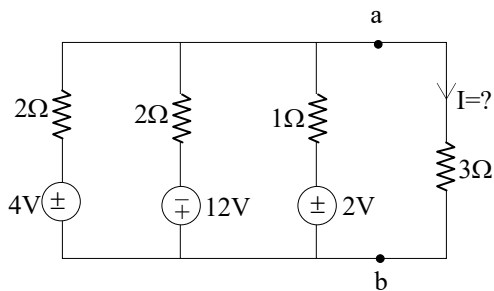

By Mill Man's theorem ;

$$V' = \frac{V_1 G_1 + V_2 G_2 + V_3 G_3}{G_1 + G_2 + G_3}$$

$$\equiv \frac{\frac{4}{2} - \frac{12}{2} + \frac{2}{1}}{\left(\frac{1}{2} + \frac{1}{2} + 1\right)} = \frac{4 - 12 + 2}{2 * 2}$$

$$\equiv -1V$$

$$\therefore V' = -1V$$

$$\frac{1}{R^1} = \frac{1}{R_1} + \frac{1}{R_2} + \frac{1}{R_3} = \frac{1}{2} + \frac{1}{2} + 1 = 2$$

$$\therefore R^1 = \frac{1}{2} \Omega$$

$$I = \frac{-1}{\left(\frac{1}{2} + 3\right)}$$

$$I = -\frac{2}{7} A$$

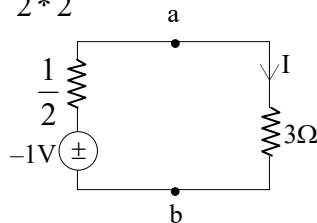

22. Ans: (d)

Sol:

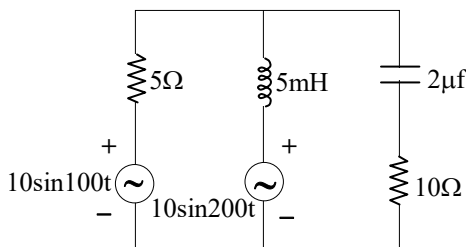

Since the two different frequencies are operating on the network simultaneously; always the super position theorem is used to

evaluate the responses since the reactive elements are frequency sensitive

$$\text{i.e., } Z_L = j\omega L \text{ and } Z_C = \frac{1}{j\omega C} \Omega.$$

23. Ans: Millman's theorem

Sol: In the above case if both the source are 100rad/sec, each then Millman's theorem is more conveniently used.

24.

Sol:

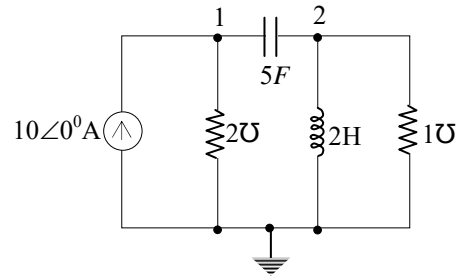

25.

Sol:

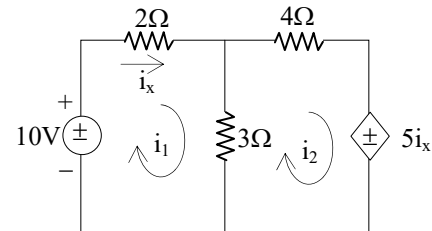

Nodal equations

$$i = GV$$

$$i_x = i_1$$

$$10 = 2i_1 + 3(i_1 - i_2) \dots\dots\dots (1)$$

$$0 = 4i_2 + 2i_x + 3(i_2 - i_1) \dots\dots\dots (2)$$

$$V_x = V_1$$

$$10 = 2V_1 - 3(V_1 - V_2) \dots\dots\dots (3)$$

$$0 = 4V_2 + 2V_x + 3(V_2 - V_1) \dots\dots\dots (4)$$

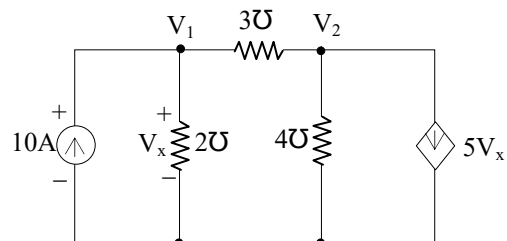

Chapter 3 Transient Circuit Analysis

Class Room Practice Solutions

01.
Sol:

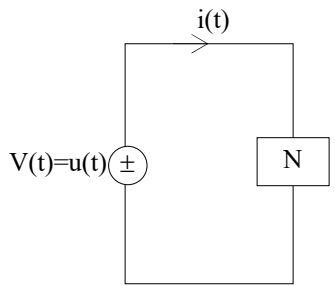

$i(t) = e^{-3t}A$ for $t > 0$ (given)
 Determine the elements & their connection
 $\frac{\text{Response Laplace transform}}{\text{Excitation Laplace transform}} = \text{System transfer function}$

$$\text{i.e., } \frac{I(s)}{V(s)} = H(s) = \frac{\frac{1}{s+3}}{\frac{1}{s}} = \frac{s}{s+3}$$

$$= y(s) = \frac{1}{Z(s)}$$

$$\therefore Z(s) = \left(\frac{s+3}{s} \right)$$

$$= 1 + \frac{1}{s} = R + \frac{1}{sC}$$

$\therefore R = 1\Omega$ and $C = \frac{1}{3}F$ are in series

02. Ans: (c)
 Sol: The impulse response of first order system is Ke^{-2t} .

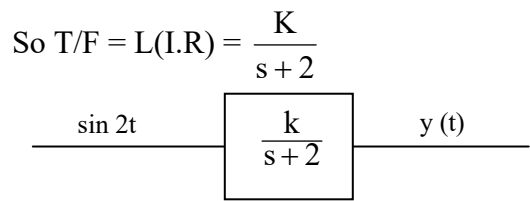

$$G(s) = \frac{K}{s+2}$$

$$|G(j\omega)| = \frac{K}{\sqrt{\omega^2 + 2^2}} = \frac{K}{2\sqrt{2}}$$

$$\angle G(j\omega) = -\tan^{-1} \frac{\omega}{2} = -\tan^{-1} 1 = -\frac{\pi}{4}$$

So steady state response will be

$$y(t) = \frac{K}{2\sqrt{2}} \sin\left(2t - \frac{\pi}{4}\right)$$

03.
Sol:

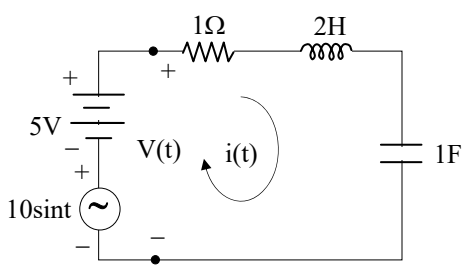

By KVL $\Rightarrow v(t) = (5 + 10\sin t)$ volt
 Evaluating the system transfer function $H(s)$.
 $\frac{\text{Desired response L.T}}{\text{Excitation response L.T}} = \text{System transfer function}$

$$\frac{I(s)}{V(s)} = H(s) = Y(s) = \frac{1}{Z(s)} = \frac{1}{\left(R + sL + \frac{1}{sC} \right)}$$

$$H(s) = \frac{s}{(2s^2 + s + 1)}$$

$$H(j\omega) = \frac{1}{\left(1 + \frac{1}{j\omega} + 2j\omega \right)}$$

II. Evaluating at corresponding ω_s of the input
 $H(j\omega)|_{\omega=0} = 0$
 $H(j\omega)|_{\omega=1} = \frac{1}{\sqrt{2}} \angle -45^\circ$



$$\text{III. } \frac{I(s)}{V(s)} = H(s)$$

$$I(s) = H(s)V(s)$$

$$i(t) = 0 \times 5 + \frac{1}{\sqrt{2}} \times 10 \sin(t - 45^\circ)$$

$$i(t) = 7.07 \sin(t - 45^\circ) \text{ A}$$

OBS: DC is blocked by capacitor in steady state

04.

$$\text{Sol: } \frac{V(s)}{I(s)} = H(s) = Z(s) = \frac{1}{Y(s)} = \frac{1}{\left(\frac{1}{R} + \frac{1}{sL} + sC\right)}$$

$$H(s) = \frac{1}{\left(1 + \frac{1}{s} + s\right)}$$

$$H(j\omega) \Big|_{\omega=1} = \frac{1}{\left(1 + \frac{1}{j} + j\right)} = 1$$

$$V(s) = I(s) H(s) = \sin t$$

$$v(t) = \sin t \text{ Volts}$$

05.

$$\text{Sol: } \tau = \frac{L_{eq}}{R_{eq}}$$

R_{eq} :

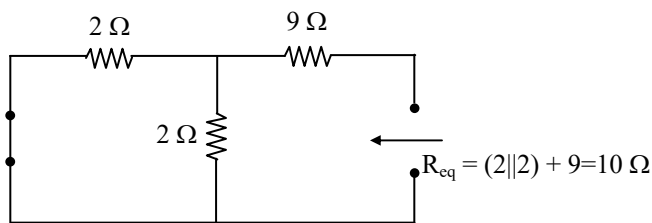

$$R_{eq} = (2 \parallel 2) + 9 = 10 \Omega$$

L_{eq} :

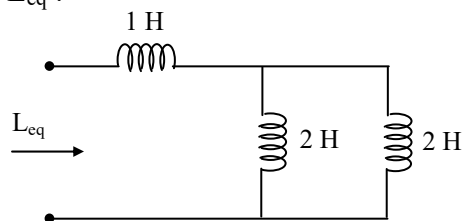

$$L_{eq} = (2 \parallel 2) + 1 = 2 \text{ H}$$

$$\therefore \tau = \frac{L_{eq}}{R_{eq}} = \frac{2}{10} = 0.2 \text{ sec}$$

06.

$$\text{Sol: } \tau = R_{eq} C_{eq}$$

R_{eq} :

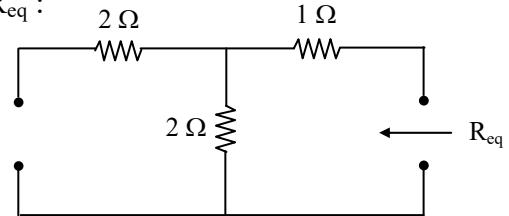

$$R_{eq} = 3 \Omega$$

C_{eq} :

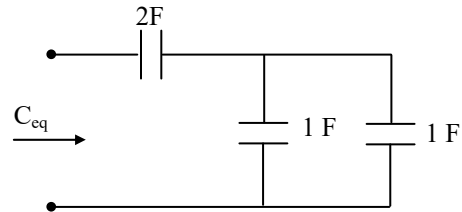

$$C_{eq} = 1 \text{ F}$$

$$\therefore \tau = 3 \times 1 = 3 \text{ sec}$$

07.

$$\text{Sol: } \tau = R_{eq} C$$

R_{eq} :

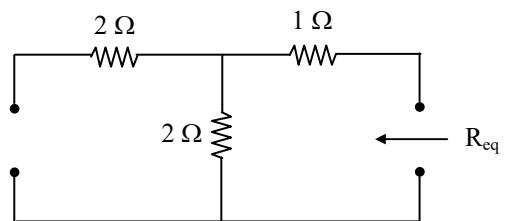

$$R_{eq} = 3 \Omega$$

$$\therefore \tau = 3 \times 1 = 3 \text{ sec}$$

08.

Sol: Let us assume that switch is closed at $t = -\infty$, now we are at $t = 0^-$ instant, still the switch is closed i.e., an infinite amount of time, the independent dc source is connected to the network and hence it is said to be in steady state.



In steady state, the inductor acts as short circuit and nature of the circuit is resistive.

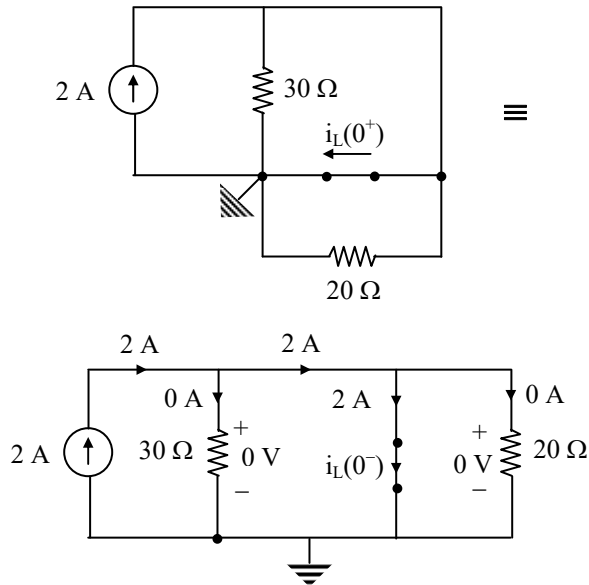

At $t = 0^-$: Steady state: A resistive circuit

Note: The number of initial conditions to be evaluated at just before the switching action is equal to the number of memory elements present in the network.

(i) $t = 0^-$

$$i_L(0^-) = 2 = i_L(0^+)$$

$$E_L(0^-) = \frac{1}{2} L i_L^2(0^-) = \frac{1}{2} \times 4 \times 2^2 = 8J = E_L(0^+)$$

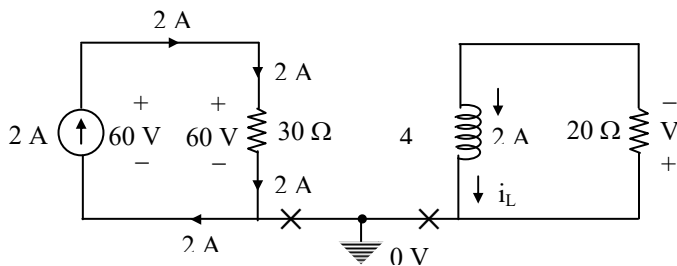

For $t \geq 0$

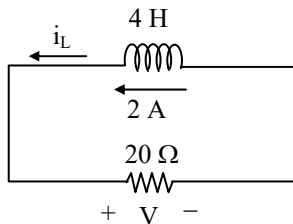

For $t \geq 0$: Source free circuit

$$I_0 = 2 \text{ A} ; \tau = \frac{L}{R} = \frac{4}{20} = \frac{1}{5} \text{ sec}$$

$$i_L = I_0 e^{-\frac{t}{\tau}}$$

$$i_L = 2 e^{-5t} \text{ for } 0 \leq t \leq \infty$$

$$V_L = L \frac{di_L}{dt} = -40 e^{-5t} \text{ V for } 0 \leq t \leq \infty$$

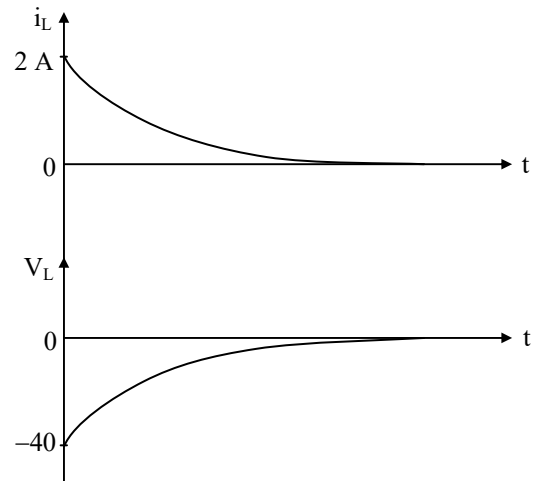

$$t = 5\tau = 5 \times \frac{1}{5} = 1 \text{ sec for steady state}$$

practically i.e., with in 1 sec the total 8 J stored in the inductor will be delivered to the resistor.

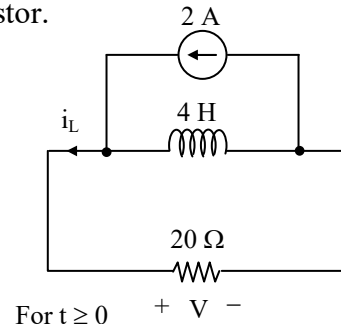

For $t \geq 0$

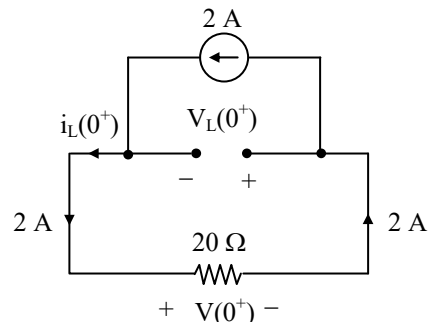

At $t = 0^+$: Resistive circuit : Network is in transient state



By KCL ;

$$-2 + i_L(0^+) = 0$$

$$i_L(0^+) = 2 \text{ A}$$

$$V(0^+) = R i_L(0^+) \text{ |By Ohm's law}$$

$$V(0^+) = 20 (2) = 40 \text{ V}$$

By KVL ;

$$V_L(0^+) + V(0^+) = 0$$

$$V_L(0^+) = -V(0^+) = -40 \text{ V} = V_L(t)|_{t=0^+}$$

Observations :

$$t = 0^-$$

$$i_L(0^-) = 2 \text{ A}$$

$$i_{20\Omega}(0^-) = 0 \text{ A}$$

$$V_{20\Omega}(0^-) = 0 \text{ V}$$

$$V_L(0^-) = 0 \text{ V}$$

$$t = 0^+$$

$$i_L(0^+) = 2 \text{ A}$$

$$i_{20\Omega}(0^+) = 2 \text{ A}$$

$$V_{20\Omega}(0^+) = 40 \text{ V}$$

$$V_L(0^+) = -40 \text{ V}$$

Conclusion :

To keep the same energy as $t = 0^-$ and to protect the KCL and KVL in the circuit (i.e., to ensure the stability of the network), the inductor voltage, the resistor current and its voltage can change instantaneously i.e., within zero time at $t = 0^+$.

(2)

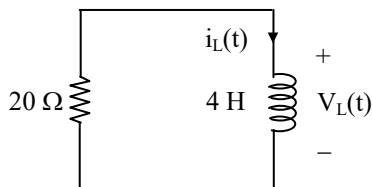

For $t \geq 0$

$$i_L(t) = 2 e^{-5t} \text{ A for } 0 \leq t \leq \infty$$

$$V_L(t) = -40 e^{-5t} \text{ V for } 0 \leq t \leq \infty$$

Conclusion :

For all the source free circuits, $V_L(t) = -ve$ for $t \geq 0$, since the inductor while acting as a temporary source (upto 5τ), it discharges from positive terminal i.e., the current will flow from negative to positive terminals. (This is the must condition required for delivery, by Tellegan's theorem)

$$(3) V_L(0^+) = -40 \text{ V}$$

$$V_L(t)|_{t=0^+} = -40 \text{ V}$$

$$L \frac{d i_L(t)}{dt} \Big|_{t=0^+} = -40$$

$$\frac{d i_L(t)}{dt} \Big|_{t=0^+} = -\frac{40}{L} = -\frac{40}{4} = -10 \text{ A/sec}$$

Check :

$$i_L(t) = 2 e^{-5t} \text{ A for } 0 \leq t \leq \infty$$

$$\frac{d i_L(t)}{dt} = -10 e^{-5t} \text{ A/sec for } 0 \leq t \leq \infty$$

$$\frac{d i_L(t)}{dt} \Big|_{t=0^+} = -10 \text{ A/sec}$$

09.

Sol:

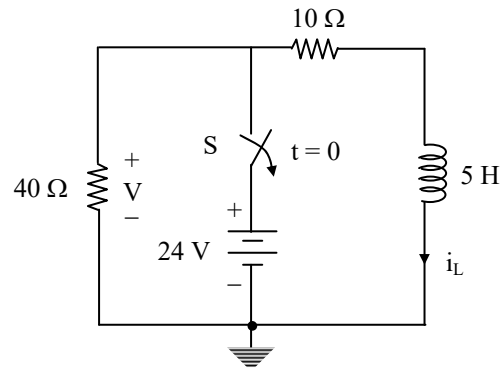

$$i_L(0^+) = 2.4 \text{ A}$$

$$V(0^+) = -96 \text{ V}$$

$$i_L(t) = 2.4 e^{-10t} \text{ A for } 0 \leq t \leq \infty$$

10.

Sol:

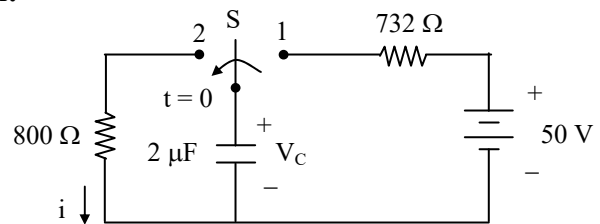

$$V_C(0^+) = 50 \text{ V} ; i(0^+) = 62.5 \text{ mA}$$



$$V_C(t) = 50 e^{-\frac{t}{1.6 \times 10^{-3}}} \text{ V for } t \geq 0$$

$$i_C = C \frac{dV_C}{dt} \quad \left| \begin{array}{l} \text{By Ohm's law} \end{array} \right.$$

11.

Sol:

Case(i): $t < 0$

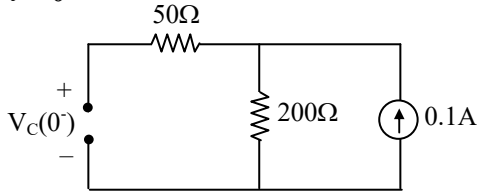

$$V_C(0^-) = 20\text{V} \text{ \& } i(0^-) = 0.1\text{A}$$

∴ capacitor never allows sudden changes in voltages

$$V_C(0^+) = V_C(0^-) = V_C(0^+) = 20\text{V}$$

Case(ii): $t > 0$

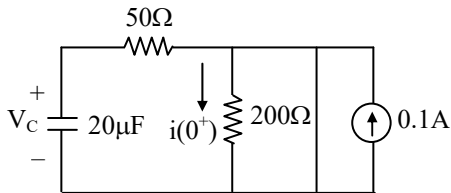

To find the time constant $\tau = R_{eq}C$

After switch closed

$$R_{eq} = 50\Omega \quad C = 20\mu\text{F}$$

$$i(0^+) = 0\text{A}$$

$$\tau = 50 \times 20\mu$$

$$\tau = 1\text{msec}$$

$$V_C(t) = V_0 e^{-t/\tau} = 20 e^{-t/1\text{m}}$$

$$V_C(t) = 20 e^{-t/1\text{m}} \text{V}; \quad 0 \leq t \leq \infty$$

12.

Sol: After performing source transformation ;

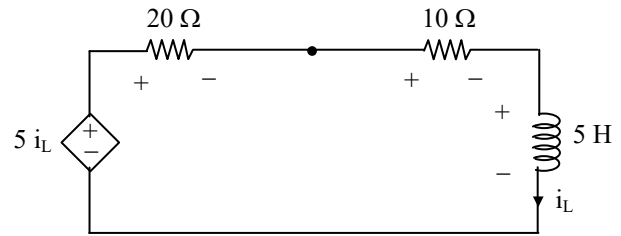

By KVL;

$$5 i_L - 30 i_L - 5 \frac{di_L}{dt} = 0$$

$$\frac{di_L}{dt} + 5 i_L = 0$$

$$(D + 5) i_L = 0$$

$$i_L(t) = K e^{-5t} \text{ A for } 0 \leq t \leq \infty$$

$$\tau = \frac{1}{5} \text{ sec}$$

13.

Sol: $i_{L_1}(0) = 10 \text{ A} ; i_{L_2}(0) = 2 \text{ A}$

$$i_{L_1}(t) = I_0 e^{-\frac{t}{\tau}}$$

$$\tau = \frac{L}{R} = \frac{1}{1} = 1 \text{ sec}$$

$$i_{L_1}(t) = 10 e^{-t} \text{ A}$$

$$\text{Similarly, } i_{L_2}(t) = I_0 e^{-\frac{t}{\tau}}$$

$$\tau = \frac{L}{R} = 2 \text{ sec}$$

$$i_{L_2}(t) = 20 e^{-\frac{t}{2}} \text{ A}$$

14.

Sol:

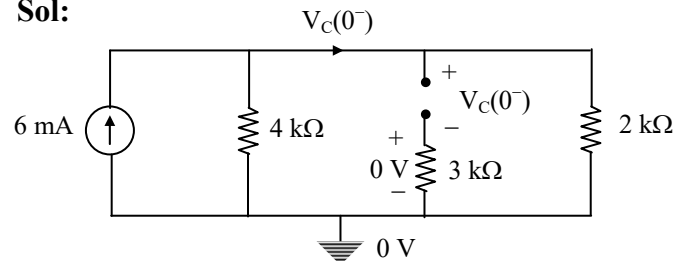



At $t = 0^-$: Steady state : A resistive circuit
By Nodal :

$$-6 \text{ mA} + \frac{V_C(0^-)}{4 \text{ K}} + \frac{V_C(0^-)}{2 \text{ K}} = 0$$

$$V_C(0^-) = 8 \text{ V} = V_C(0^+)$$

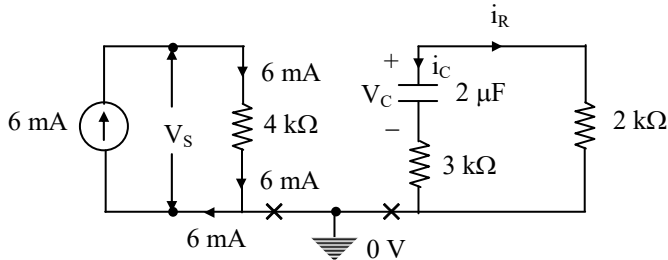

For $t \geq 0$: A source free circuit

$$V_s = 6 \text{ m} \times 4 \text{ K} = 24 \text{ V}$$

$$\tau = R_{eq} C = (5 \text{ K}) 2 \mu = 10 \text{ m sec}$$

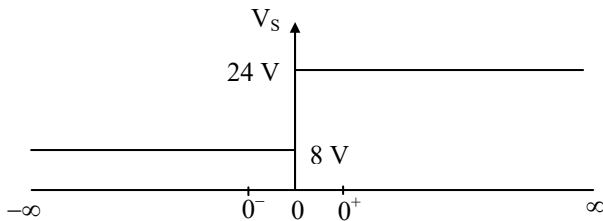

$$V_C = 8 e^{-\frac{t}{10 \text{ m}}} = 8 e^{-100t} \text{ V for } 0 \leq t \leq \infty$$

$$i_C = C \frac{dV_C}{dt} \Big|_{\text{By Ohm's law}} = -1.6 e^{-100t} \text{ mA for } 0 \leq t \leq \infty$$

By KCL:

$$i_C + i_R = 0$$

$$i_R = -i_C = 1.6 e^{-100t} \text{ mA for } 0 \leq t \leq \infty$$

Observation:

In all the source free circuit, $i_C(t) = -ve$ for $t \geq 0$ because the capacitor while acting as a temporary source it discharges from the +ve terminal i.e., current will flow from -ve to +ve terminals.

15.

Sol: By KCL :

$$i(t) = i_R(t) + i_L(t)$$

$$= \frac{V_R(t)}{R} + \frac{1}{L} \int_{-\infty}^t V_L(t) dt$$

$$= \frac{V_s(t)}{10} + i_L(0) + \frac{1}{L} \int_0^t V_s(t) dt$$

$$i(t) = 4t + 5 + 4t^2$$

$$i(t) |_{t=2 \text{ sec}} = 8 + 16 + 5 = 29 \text{ A}$$

16. Ans: (c)

17.

Sol:

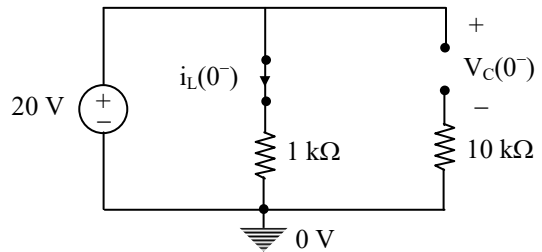
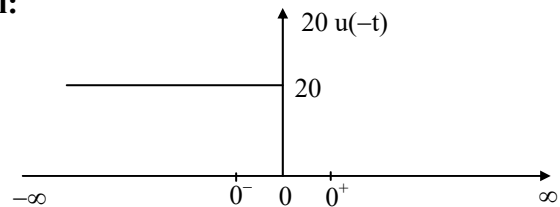

At $t = 0^-$: steady state: A resistive circuit.

(i) $t = 0^-$

$$V_C(0^-) = 20 \text{ V} = V_C(0^+)$$

$$i_L(0^-) = \frac{20}{1 \text{ K}} = 20 \text{ mA} = i_L(0^+)$$

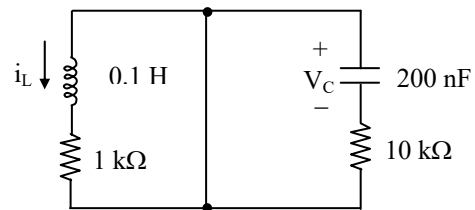

For $t \geq 0$: A source free RL & RC circuit

$$\tau = \frac{0.1}{1 \text{ K}} = 100 \mu \text{ sec}$$

$$\tau_C = 200 \times 10^{-9} \times 10 \times 10^3 = 2 \text{ m sec}$$

$$\frac{\tau_C}{\tau_L} = 20 ; \tau_C = 20 \tau_L$$



Observation:

$\tau_L < \tau_C$; therefore the inductive part of the circuit will achieve steady state quickly i.e., 20 times faster.

$$V_C = 20 e^{-\frac{t}{\tau_C}} \text{ V for } 0 \leq t \leq \infty$$

$$i_L = 20 e^{-\frac{t}{\tau_L}} \text{ mA for } 0 \leq t \leq \infty$$

$$V_L = L \frac{di_L}{dt} \quad \left| \begin{array}{l} \text{By Ohm's law} \end{array} \right.$$

$$i_C = C \frac{dV_C}{dt} \quad \left| \begin{array}{l} \text{By Ohm's law} \end{array} \right.$$

18.

Sol: At $t = 0^-$

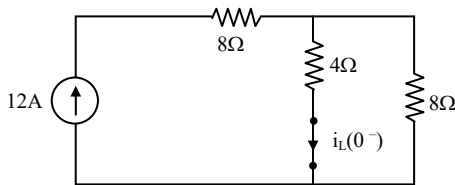

$$\Rightarrow i_L(0^-) = \frac{12 \times 8}{8 + 4} = 8A$$

At $t = 0^+$

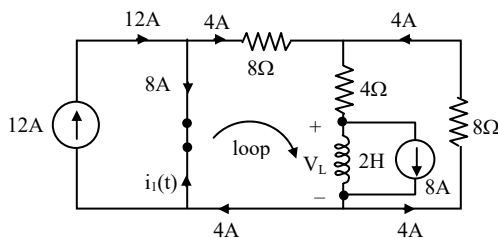

$$\therefore i_1(0^+) = -8A$$

Applying KVL in the loop,

$$\Rightarrow 8(4) + 4(8) + V_L = 0$$

$$\Rightarrow V_L = -64$$

$$\Rightarrow L \frac{di_L}{dt} = -64$$

$$\Rightarrow \frac{di_L}{dt} = -32 \text{ A/sec}$$

19. Ans: (c)

Sol:

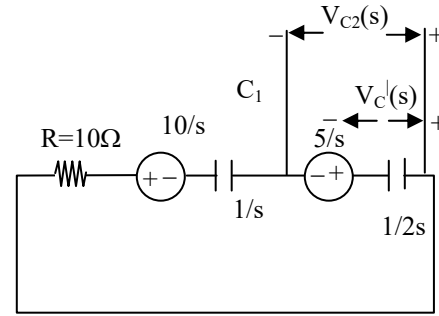

$$V_c'(s) = \frac{\frac{5}{s} \left(\frac{1}{2s} \right)}{R + \frac{1}{s} + \frac{1}{2s}}$$

$$= \frac{5}{2s^2} = \frac{5}{2Rs + 2 + 1} = \frac{5}{s(2Rs + 3)}$$

$$V_{c_2}(\infty) - V_c'(s) - \frac{5}{s} = 0$$

$$V_c(\infty) = V_c'(s) + \frac{5}{s}$$

$$V_c(\infty) = \lim_{s \rightarrow 0} s \left[\frac{5}{s(2Rs + 3)} + \frac{5}{s} \right]$$

$$= \frac{5}{3} + 5 = \frac{20}{3}$$

20. Ans: (d)

Sol: At $t = 0$

$$L \frac{di(0)}{dt} = V_L(0)$$

$$V_L = 2 \times 3 = 6$$

$$V_L = 6V$$

$$E_2 + 6 - 8R = 0$$

$$E_2 = 8R - 6$$

$$E_2 - 4R = 0$$

$$E_2 = 4R$$

$$8R - 6 = 4R$$

$$4R = 6$$

$$R = 1.5\Omega$$

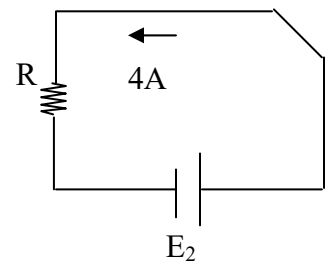
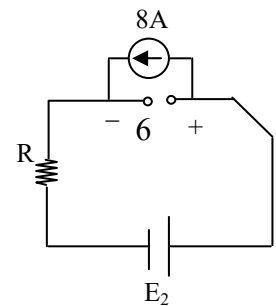



21. Ans: (d)

Sol: At $t < 0$

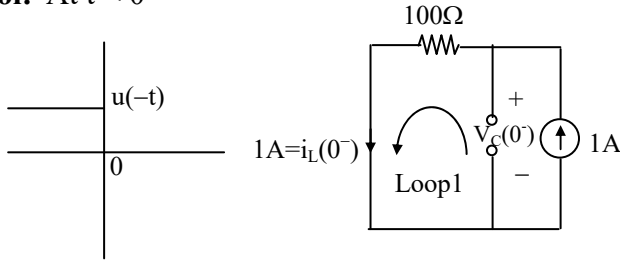

Apply KVL in loop1 $\Rightarrow V_C(0^-) - 100 = 0$
 $\Rightarrow V_C(0^-) = 100V$

At $t = 0^+$

$$V_L(0^+) = 0$$

$$L \frac{di(0^+)}{dt} = 0$$

$$\frac{di(0^+)}{dt} = 0$$

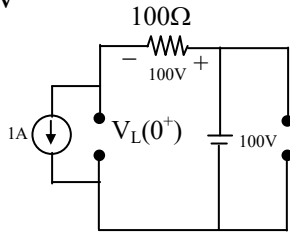

22.

Sol: Case -1 at $t = 0^+$

By redrawing the circuit

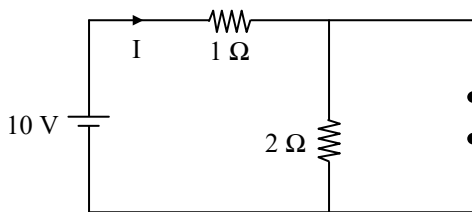

current through the battery

at $t = 0^+$ is $\frac{10}{3} A$

Case -2 at $t = \infty$

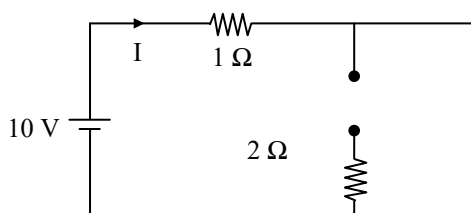

current through the battery at $t = \infty$
 is 10 Amp

23.

Sol:

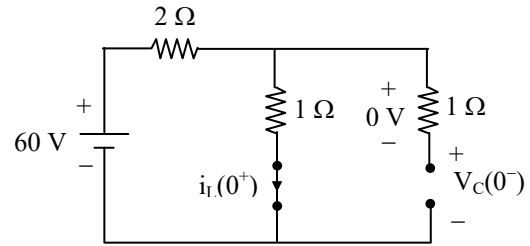

At $t = 0^-$: Steady state: A resistive circuit

(i) $t = 0^-$:

$$i_L(0^-) = \frac{60}{3} = 20 A = i_L(0^+)$$

$$V_{1\Omega} = 20 V = V_C(0^-) = V_C(0^+)$$

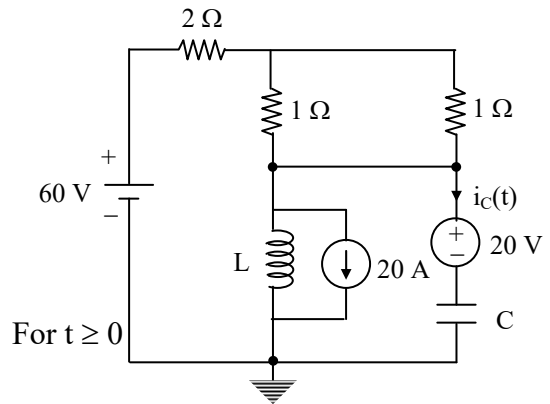

For $t \geq 0$

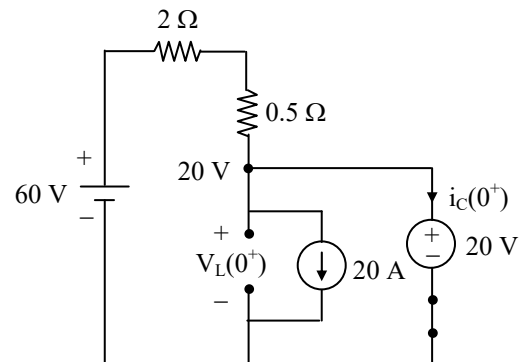

At $t = 0^+$: A resistive circuit:
 Network is in transient state

$$V_L(0^+) = 20 V$$

Nodal:

$$\frac{20 - 60}{2.5} + 20 + i_C(0^+) = 0$$

$$i_C(0^+) = -4 A$$



24.

Sol: Repeat the above problem procedure :

$$\left. \frac{di_L(t)}{dt} \right|_{t=0^+} = \frac{V_L(0^+)}{L} = 0 \text{ A/sec}$$

$$\left. \frac{dV_C(t)}{dt} \right|_{t=0^+} = \frac{i_C(0^+)}{C} = -10^6 \text{ V/sec}$$

25.

Sol: **Observation:** So, the steady state will occur either at $t = 0^-$ or at $t = \infty$, that depends where we started i.e., connected the source to the network.

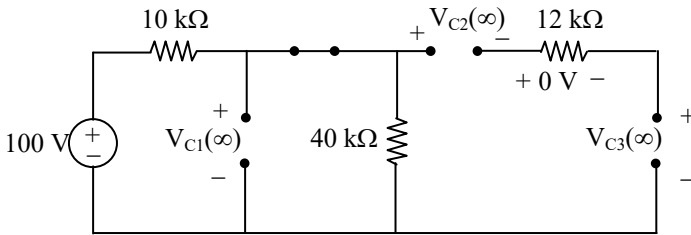

At $t = \infty$: Steady state: A Resistive circuit

$$V_{C_1}(\infty) = \frac{100}{50K} \times 40K = 80 \text{ V}$$

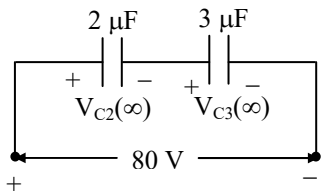

$$V_{C_2}(\infty) = \frac{80 \times 3 \mu F}{(2+3) \mu F} = 48 \text{ V}$$

$$V_{C_3}(\infty) = \frac{80 \times 2 \mu F}{5 \mu F} = 32 \text{ V}$$

26.

Sol:

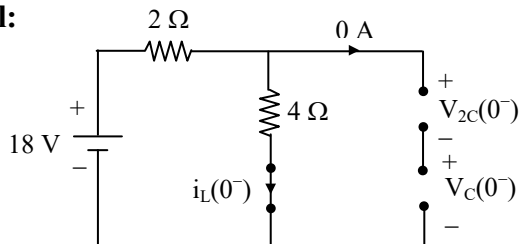

At $t = 0^-$: Circuit is in Steady state: Resistive circuit

$$i_L(0^-) = 3 \text{ A} = i_L(0^+)$$

$$V_{4\Omega} = 4 \times 3 = 12 \text{ V}$$

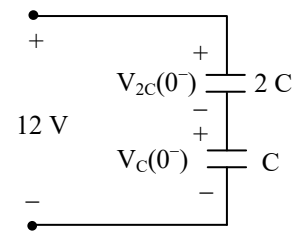

$$V_{2C}(0^-) = \frac{12 \times C}{2C + C} = 4 \text{ V} = V_{2C}(0^+)$$

$$V_C(0^-) = 8 \text{ V} = V_C(0^+)$$

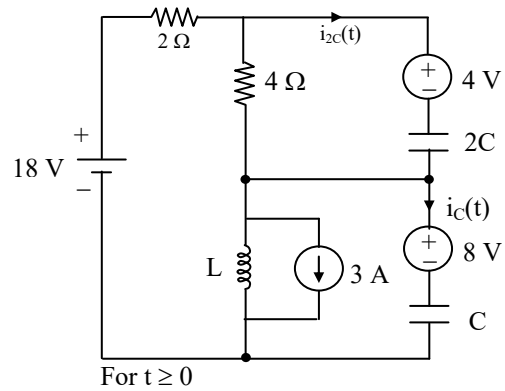

and redrawing the circuit

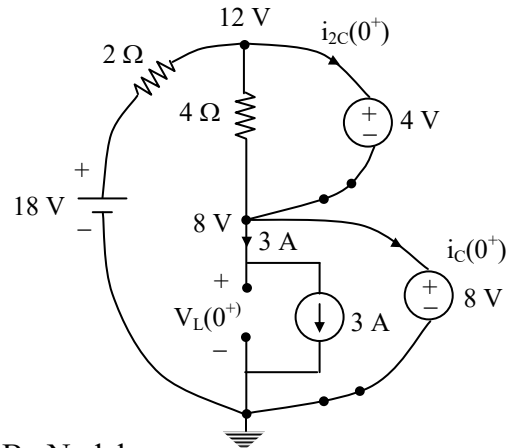

By Nodal;

$$\frac{12 - 18}{2} + \frac{12 - 8}{4} + i_{2C}(0^+) = 0$$

$$\frac{-6}{2} + \frac{4}{4} + i_{2C}(0^+) = 0$$

$$i_{2C}(0^+) = 2 \text{ A} = i_{2C}(0^-)$$

$$\frac{8 - 12}{4} - i_{2C}(0^+) + 3 + i_C(0^+) = 0$$

$$i_C(0^+) = 0 \text{ A} = i_C(0^-)$$



27.

Sol: $t = 0^-$ $t = 0^+$ $t = 0^+$

$$i_L(0^-) = 5 \text{ A} \quad i_L(0^+) = 5 \text{ A}$$

$$\frac{di_L(0^+)}{dt} = \frac{V_L(0^+)}{L} = 40$$

$$i_R(0^-) = -5 \text{ A} \quad i_R(0^+) = -1 \text{ A}$$

$$\frac{di_R(0^+)}{dt} = -40 \text{ A/sec}$$

$$i_C(0^-) = 0 \text{ A} \quad i_C(0^+) = 4 \text{ A}$$

$$\frac{di_C(0^+)}{dt} = -40 \text{ A/sec}$$

$$V_L(0^-) = 0 \text{ V}$$

$$V_L(0^+) = 120 \text{ V}$$

$$\frac{dV_L(0^+)}{dt} = 1098 \text{ V/sec}$$

$$V_R(0^-) = -150 \text{ V}$$

$$V_R(0^+) = -30 \text{ V}$$

$$\frac{dV_R(0^+)}{dt} = -1200 \text{ V/sec}$$

$$V_C(0^-) = 150 \text{ V}$$

$$V_L(0^+) = 150 \text{ V}$$

$$\frac{dV_C(0^+)}{dt} = 108 \text{ V/sec}$$

(i). $t = 0^-$

$$\text{By KCL} \Rightarrow i_L(t) + i_R(t) = 0$$

$$t = 0^- \Rightarrow i_L(0^-) + i_R(0^-) = 0$$

$$i_R(0^-) = -5 \text{ A}$$

$$V_R(t) = R i_R(t) \text{ |By Ohm's law}$$

$$V_R(0^-) = R i_R(0^-) = 30(-5) = -150 \text{ V}$$

$$\text{By KVL} \Rightarrow V_L(t) - V_R(t) - V_C(t) = 0$$

$$V_C(0^-) = V_L(0^-) - V_R(0^-) = 150 \text{ V}$$

(ii). At $t = 0^+$

$$\text{By KCL at 1}^{\text{st}} \text{ node} \Rightarrow$$

$$-4 + i_L(t) + i_R(t) = 0$$

$$-4 + i_L(0^+) + i_R(0^+) = 0$$

$$i_R(0^+) = -i_L(0^+) + 4$$

$$i_R(0^+) = -5 + 4 = -1 \text{ A}$$

$$V_R(t) = R i_R(t) \text{ |By Ohm's law}$$

$$V_R(0^+) = R i_R(0^+)$$

$$V_R(0^+) = -30 \text{ V}$$

$$\text{By KVL} \Rightarrow V_L(t) - V_R(t) - V_C(t) = 0$$

$$V_L(0^+) = V_R(0^+) + V_C(0^+) \\ = 150 - 30 = 120 \text{ V}$$

By KCL at 2nd node;

$$-5 + i_C(t) - i_R(t) = 0$$

$$i_C(0^+) = 4 \text{ A}$$

(iii). $t = 0^+$

By KCL at 1st node \Rightarrow

$$-4 + i_L(t) + i_R(t) = 0$$

$$0 + \frac{di_L(t)}{dt} + \frac{d}{dt} i_R(t) = 0$$

$$V_R(t) = R i_R(t) \text{ |By Ohm's law}$$

$$\frac{d}{dt} V_R(t) = R \frac{d}{dt} i_R(t)$$

By KVL \Rightarrow

$$V_L(t) - V_R(t) - V_C(t) = 0$$

$$\frac{dV_L(t)}{dt} - \frac{dV_R(t)}{dt} - \frac{dV_C(t)}{dt} = 0$$

By KCL at node 2:

$$-5 + i_C(t) - i_R(t) = 0$$

$$0 + \frac{d}{dt} i_C(t) - \frac{d}{dt} i_R(t) = 0$$

$$\frac{d}{dt} i_C(0^+) = -(-40) = 40 \text{ A/sec}$$

28.

Sol: Transform the network into Laplace domain

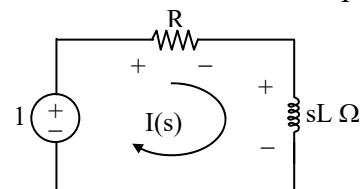

S - domain



$$V(s) = Z(s) I(s)$$

By KVL in S-domain \Rightarrow

$$1 - R I(s) - s L I(s) = 0$$

$$I(s) = \frac{1}{L} \frac{1}{\left(s + \frac{R}{L}\right)}$$

$$i(t) = \frac{1}{L} e^{-\frac{R}{L}t} \text{ A for } t \geq 0$$

29.

Sol: By Time domain approach ;

$$V_C(0^-) = 5 \times 2 = 10 \text{ V} = V_C(0^+)$$

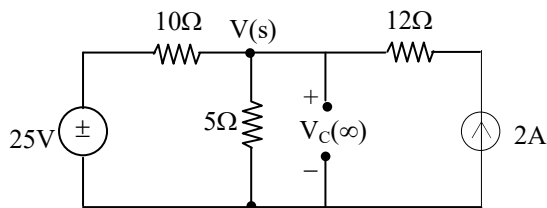

At $t = \infty$: Steady state: A resistive circuit

$$\text{Nodal } \Rightarrow \frac{V_C(\infty) - 25}{10} + \frac{V_C(\infty)}{5} - 2 = 0$$

$$V_C(\infty) = 15 \text{ V}$$

$$\tau = R_{eq} C = (5 \parallel 10) \cdot 1 = (10/3) \text{ sec}$$

$$V_C = 15 + (10 - 15) e^{-\frac{t}{(10/3)}}$$

$$V_C = 15 - 5 e^{-3t/10} \text{ V for } t \geq 0$$

$$i_C = C \frac{dV_C}{dt} = 1.5 e^{-3t/10} \text{ A for } t \geq 0$$

30.

Sol:

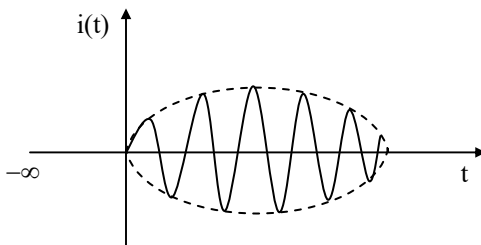

That is the response is oscillatory in nature

31.

$$\text{Sol: } i(0^-) = 0 \text{ A} = i(0^+)$$

$$i(\infty) = \frac{V}{R} \text{ A}$$

$$\tau = \frac{L}{R} \text{ sec}$$

$$i(t) = \frac{V}{R} + \left(0 - \frac{V}{R}\right) e^{-t/\tau} = \frac{V}{R} (1 - e^{-t/\tau})$$

$$V_L = \frac{L di(t)}{dt} = V e^{-Rt/L} \text{ for } t \geq 0$$

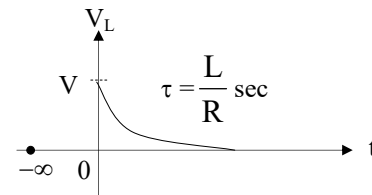
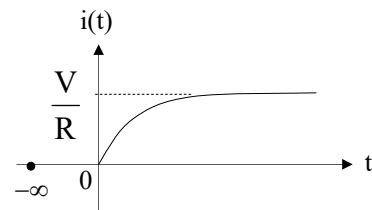

Exponentially Increasing Response

32.

$$\text{Sol: } V_C(0^-) = 0 = V_C(0^+)$$

$$V_C(\infty) = V$$

$$\tau = RC$$

$$V_C = V + (0 - V) e^{-t/\tau}$$

$$= V(1 - e^{-t/RC}) \text{ for } t \geq 0$$

$$i_C = C \frac{dV_C}{dt} = \frac{V}{R} e^{-t/RC} \text{ for } t \geq 0$$

$$= i(t)$$

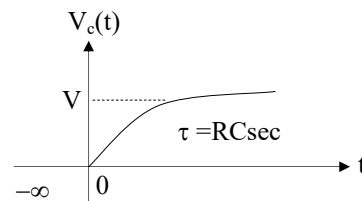

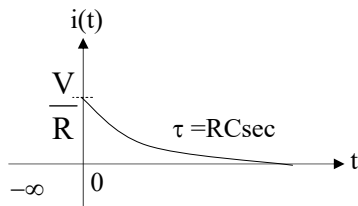

Exponentially Decreasing Response

33.

Sol: It's an RL circuit with $L = 0 \Rightarrow \tau = 0$ sec

$$i(t) = \frac{V}{R}, \forall t \geq 0 \text{ So, } 5\tau = 0 \text{ sec}$$

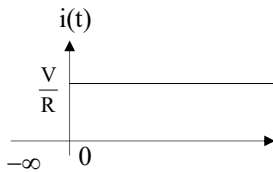

i.e. the response is constant

34.

Sol: $i_1 = \frac{100u(t) - V_L}{10}$

$$i_1 = \left(10u(t) - \frac{1}{100} \frac{di_L}{dt} \right) \text{A}$$

Nodal \Rightarrow

$$-i_1 + i_L + \frac{V_L - 20i_1}{20} = 0$$

$$-2i_1 + i_L + \frac{1}{200} \frac{di_L}{dt} = 0$$

Substitute i_1 ;

$$\frac{di_L}{dt} + 40i_L = 800u(t)$$

$$sI_L(s) - i_L(0^+) + 40I_L(s) = \frac{800}{s}$$

$$i_L(0^-) = 0\text{A} = i_L(0^+)$$

$$I_L(s) = \frac{800}{s(s+40)} = \frac{20}{s} - \frac{20}{s+40}$$

$$I_L(t) = 20u(t) - 20e^{-40t} u(t)$$

$$I_L(t) = 20(1 - e^{-40t}) u(t)$$

$$i_1 = 10u(t) - \frac{1}{100} \frac{di_L}{dt}$$

$$i_1 = (10 - 8e^{-40t}) u(t)$$

35.

Sol: By Laplace transform approach:

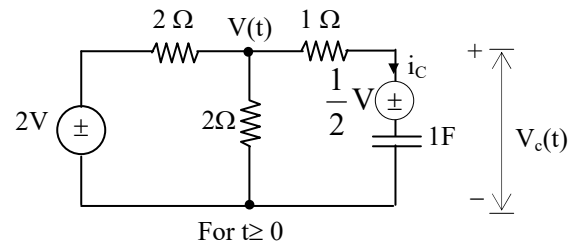

Transform the above network into the Laplace domain

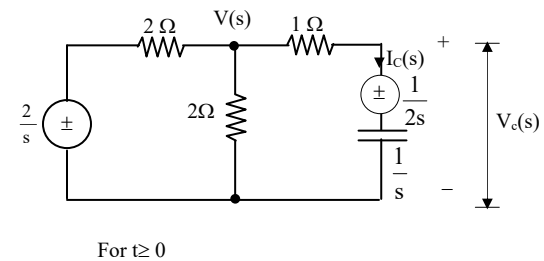

Nodal \Rightarrow

$$\frac{V(s) - \frac{2}{s}}{2} + \frac{V(s)}{2} + \frac{V(s) - \frac{1}{2s}}{1 + \frac{1}{s}} = 0$$

$$I_c(s) = \left(\frac{V(s) - \frac{1}{2s}}{1 + \frac{1}{s}} \right)$$

$$\Rightarrow i_c(t) = \frac{1}{4} e^{-\frac{t}{2}} \text{ A for } t \geq 0$$

By KVL \Rightarrow

$$V_c(s) - \frac{1}{2s} - \frac{1}{s} I_c(s) = 0$$

$$V_c(s) = \frac{1}{2s} + \frac{1}{s} I_c(s)$$

$$v_c(t) = 1 - \frac{1}{2} e^{-\frac{t}{2}} \text{ V for } t \geq 0$$

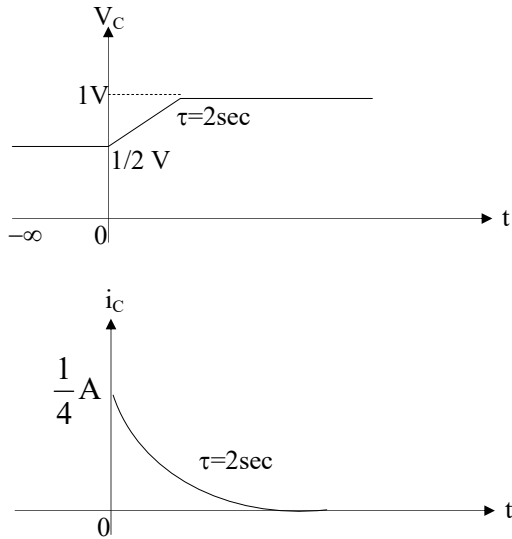

36.

Sol: By Time domain approach ;
 $V_C(0) = 6 \text{ V}$ (given)
 $V_C(\infty) = 10 \text{ V}$

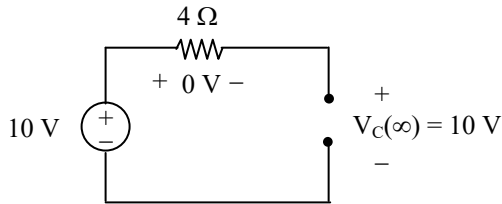

At $t = \infty$: Steady state : Resistive circuit

$$\tau = R C = 8 \text{ sec}$$

$$V_C = 10 + (6 - 10) e^{-t/8}$$

$$V_C = 10 - 4 e^{-t/8}$$

$$V_C(0) = 6 \text{ V}$$

$$i_C = C \frac{dV_C}{dt} = e^{-t/8} = i(t)$$

$$E_{4\Omega} = \int_0^{\infty} (e^{-t/8})^2 4 dt = 16 \text{ J}$$

37.

Sol:

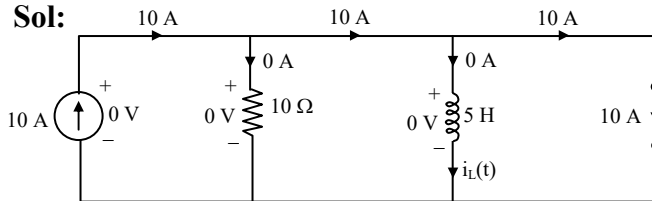

At $t = 0^-$: Network is not in steady state i.e., unenergised

$t = 0^-$:

$$i_L(0^-) = 0 \text{ A} = i_L(0^+)$$

$$V_L(0^+) = 10 \times 10 = 100 \text{ V}$$

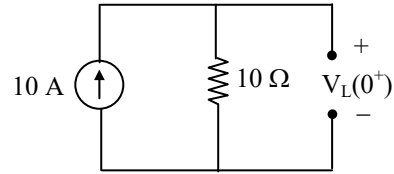

At $t = 0^+$: Network is in transient state : A resistive circuit

$$i_L(\infty) = 10 \text{ A (since inductor becomes short)}$$

$$\tau = \frac{L}{R} = \frac{5}{10} = 0.5 \text{ sec}$$

$$i_L(t) = 10 + (0 - 10) e^{-t/\tau}$$

$$= 10 (1 - e^{-t/0.5}) \text{ A for } 0 \leq t \leq \infty$$

$$V_L(t) = L \frac{d}{dt} i_L(t) = 100 e^{-2t} \text{ V for } 0 \leq t \leq \infty$$

$$E_L \Big|_{t=5\tau \text{ or } t=\infty} = \frac{1}{2} Li^2 = \frac{1}{2} \times 5 \times 10^2 = 250 \text{ J}$$

38. Ans: (b)

Sol:

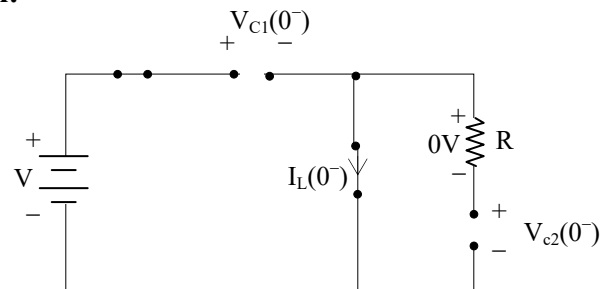

At $t = 0^-$: Steady state: A resistive circuit

By KVL \Rightarrow

$$V - V_{C1}(0^-) = 0$$

$$V_{C1}(0^-) = V = V_{C1}(0^+)$$

$$V_{C2}(0^-) = 0 \text{ V} = V_{C2}(0^+)$$

$$i_L(0^-) = 0 \text{ A} = i_L(0^+)$$

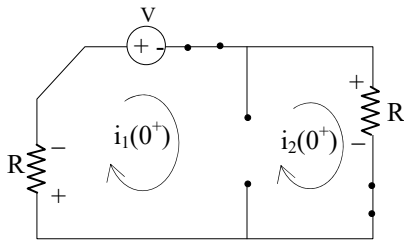
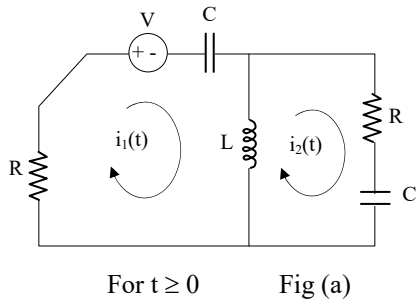

At $t = 0^+$: A resistive circuit: Network is in transient state.

$$i_1(0^+) = i_2(0^+)$$

By KVL \Rightarrow

$$-Ri_1(0^+) - V - Ri_1(0^+) = 0$$

$$i_1(0^+) = \frac{-V}{2R} = i_2(0^+)$$

OBS: $i_L(t) = i_1(t) \sim i_2(t)$

At $t = 0^+ \Rightarrow$

$$i_L(0^+) = i_1(0^+) \sim i_2(0^+)$$

$$= 0A \Rightarrow \text{Inductor: open circuit}$$

39.

Sol: (b) Transform the network given in fig. (a) into the S-domain.

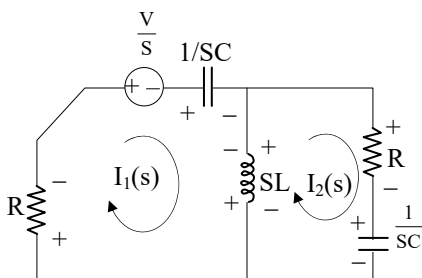

$$V(s) = Z(s) \cdot I(s)$$

By KVL in S-domain \Rightarrow

$$-RI_1(s) - \frac{V}{s} - \frac{I_1(s)}{sC} - sL(I_1(s) - I_2(s)) = 0$$

Similarly:

$$-RI_2(s) - \frac{I_2(s)}{sC} - sL(I_2(s) - I_1(s)) = 0$$

$$\begin{bmatrix} R + sL + \frac{1}{sC} & -sL \\ -sL & R + sL + \frac{1}{sC} \end{bmatrix} \begin{bmatrix} I_1(s) \\ I_2(s) \end{bmatrix} = \begin{bmatrix} -V/s \\ 0 \end{bmatrix}$$

40.

Sol: Evaluation of $i_L(t)$ and $e_L(t)$ for $t \geq 0$ by Laplace transform approach.

$$i_L(0^+) = 6A; i_L(\infty) = 4A$$

$$e_L(0^+) = 8V; e_L(\infty) = 8V$$

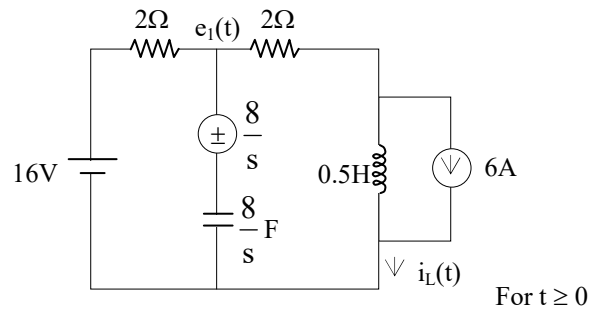

Transform the above network into Laplace domain.

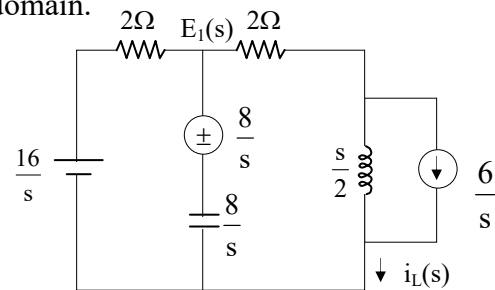

S-domain :

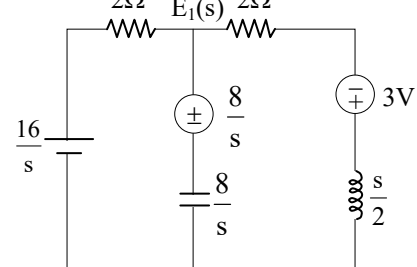



Nodal in S-domain

$$\frac{E_1(s) - 16/s}{2} + \frac{E_1(s) - \frac{8}{s}}{\frac{8}{s}} + \frac{E_1(s) + 3}{2 + \frac{s}{2}} = 0$$

$$E_1(s) = \frac{8}{s} \left(\frac{s^2 + 6s + 32}{s^2 + 8s + 32} \right)$$

$$E_1(s) = \frac{8}{s} \left(1 - \frac{2s}{(s+4)^2 + 4^2} \right)$$

$$e_1(t) = 8 - 4e^{-4t} \sin 4t \text{ V for } t \geq 0$$

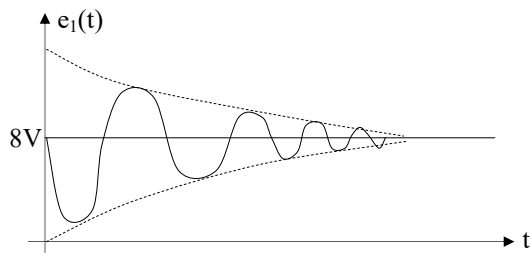

$$I_L(s) = \frac{E_1(s) + 3}{2 + \frac{s}{2}}$$

$$i_L(t) = 4 + 2e^{-4t} \cos 4t \text{ A}$$

for $t \geq 0$ $\omega_n = 4 \text{ rad/sec}$

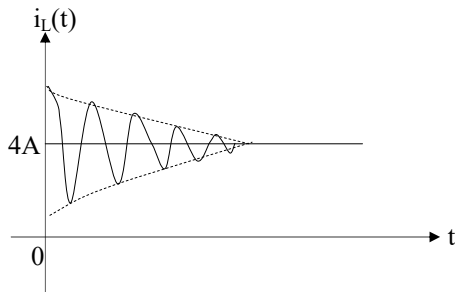

OBS: $\tau = \frac{1}{4} \text{ sec} = \frac{1}{\xi \omega_n} \left| \omega_n = \frac{1}{\sqrt{LC}} = \frac{1}{\sqrt{\frac{1}{2} \times \frac{1}{8}}} = 4 \right.$

$$\frac{1}{4} \times \omega_n = \frac{1}{\xi}$$

$$\xi = \frac{4}{\omega_n} = \frac{4}{4} = 1$$

$\xi = 1$ (A critically damped system)

41.

Sol: $\omega t|_{t=t_0} = \tan^{-1} \left(\frac{\omega L}{R} \right)$

$$\omega t_0 = \tan^{-1} \left(\frac{\omega L}{R} \right)$$

$$2\pi(50)t_0 = \tan^{-1} \left(\frac{2\pi(50)(0.01)}{5} \right)$$

$$t_0 = 32.14 \times \frac{\pi}{180^\circ}$$

$$t_0 = 1.78 \text{ msec.}$$

So, by switching exactly at 1.78 msec from the instant voltage becomes zero, the current is free from Transient.

42.

Sol: $\omega t_0 + \phi = \tan^{-1}(\omega CR) + \frac{\pi}{2}$

$$2t_0 + \frac{\pi}{4} = \tan^{-1}(\omega CR) + \frac{\pi}{2}$$

$$2t_0 + \frac{\pi}{4} = \tan^{-1} \left(2 \left(\frac{1}{2} \right) (1) \right) + \frac{\pi}{2} = \frac{\pi}{4} + \frac{\pi}{2}$$

$$2t_0 = \frac{\pi}{2} \Rightarrow t_0 = 0.785 \text{ sec}$$

Class Room Practice Solutions

01.

$$\text{Sol: } I_{\text{avg}} = I_{\text{dc}} = \frac{1}{T} \int_0^T i(t) dt = 3 + 0 + 0 = 3A$$

$$I_{\text{rms}} = \sqrt{\frac{1}{T} \int_0^T i^2(t) dt}$$

$$= \sqrt{3^2 + \left(\frac{4\sqrt{2}}{\sqrt{2}}\right)^2 + \left(\frac{5\sqrt{2}}{\sqrt{2}}\right)^2 + 0 + 0 + 0}$$

$$= 5\sqrt{2}A$$

02.

$$\text{Sol: } V_{\text{dc}} = V_{\text{avg}} = \frac{1}{T} \int_0^T V(t) dt = 2V$$

Here the frequencies are same, by doing simplification

$$v(t) = 2 - 3\sqrt{2} \left(\cos 10t \times \frac{1}{\sqrt{2}} - \sin 10t \times \frac{1}{\sqrt{2}} \right)$$

$$+ 3\cos 10t = 2 + 3\sin 10t \text{ V}$$

$$\text{So } V_{\text{rms}} = \sqrt{(2)^2 + \left(\frac{3}{\sqrt{2}}\right)^2} = \sqrt{8.5} \text{ V}$$

03.

$$\text{Sol: } X_{\text{avg}} = X_{\text{dc}} = \frac{1}{T} \int_0^T x(t) dt = 0$$

$$X_{\text{rms}} = \sqrt{\frac{1}{T} \int_0^T x^2(t) dt} = \frac{A}{\sqrt{3}}$$

04. Ans: (a)

Sol: For a symmetrical wave (i.e., area of positive half cycle = area of negative half cycle.) The RMS value of full cycle is same as the RMS value of half cycle.

05.

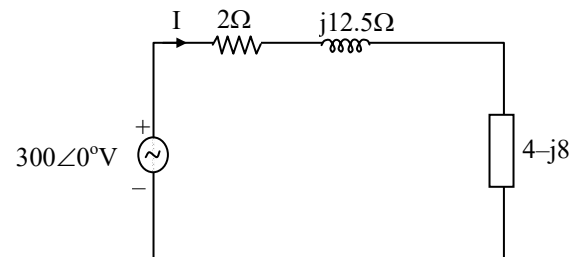
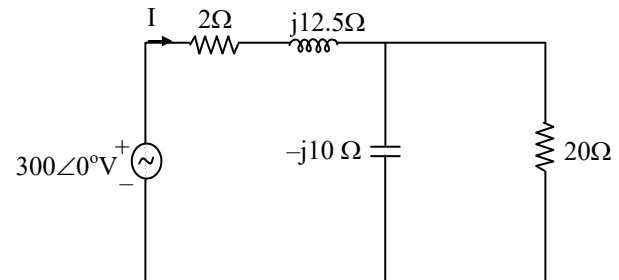
Sol: Complex power, $S = VI^*$ 

$$\Rightarrow I = \frac{300\angle 0^\circ}{2 + j12.5 + 4 - j8}$$

$$\Rightarrow I = 40\angle -36.86^\circ$$

∴ Complex power, $S = VI^*$

$$= 300\angle 0^\circ \times 40\angle 36.86^\circ$$

$$= 9600 + j7200$$

∴ Reactive power delivered by the source

$$Q = 72000 \text{ VAR}$$

$$= 7.2 \text{ KVAR}$$

06.

$$\text{Sol: } Z = j1 + (1-j1) \parallel (1+j2) = 1.4 + j0.8$$

$$I = \frac{E_1}{Z} \Big|_{\text{By ohm's law}} = \frac{10\angle 20^\circ}{1.4 + j0.8}$$

$$= 6.2017\angle -9.744^\circ \text{ A}$$



$$I_1 = \frac{I(1+j2)}{1-j1+1+j2} = 6.2017 \angle 27.125^\circ \text{ A}$$

$$I_2 = \frac{I(1-j1)}{1-j1+1+j2} = 3.922 \angle -81.31^\circ \text{ A}$$

$$E_2 = (1-j1)I_1 = 8.7705 \angle -17.875^\circ \text{ V}$$

$$E_0 = 0.5I_2 = 1.961 \angle -81.31^\circ \text{ V}$$

07.

Sol: Since two different frequencies are operating on the network simultaneously always the super position theorem is used to evaluate the response.

By SPT: (i)

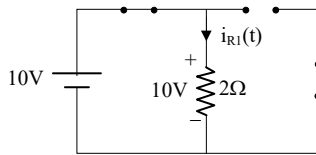

Network is in steady state, therefore the network is resistive. $I_{R1}(t) = \frac{10}{2} = 5\text{A}$

(ii)

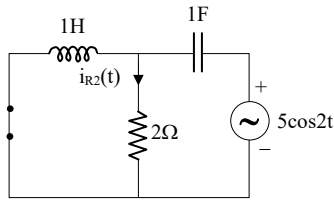

Network is in steady state
As impedances of L and C are present because of $\omega = 2$. They are physically present.

$$Z_L = j\omega L; Z_C = \frac{1}{j\omega C} \Big|_{\omega=2}$$

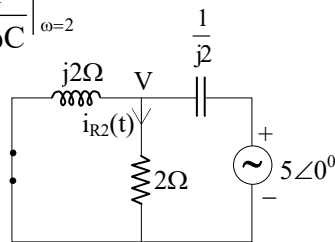

Network is in phasor domain

Nodal \Rightarrow

$$\frac{V}{j2} + \frac{V}{2} + \frac{V - 5\angle 0^\circ}{-j0.5} = 0$$

$$V = 6.32 \angle 18.44^\circ$$

$$I_{R2} = \frac{V}{2} = 3.16 \angle 18.44^\circ = 3.16 e^{j18.14^\circ}$$

$$i_{R2}(t) = R.P.[I_{R2}e^{j2t}] \text{ A}$$

$$= 3.16 \cos(2t + 18.44^\circ)$$

By super position theorem,

$$i_R(t) = i_{R1}(t) + i_{R2}(t)$$

$$= 5 + 3.16 \cos(2t + 18.44^\circ) \text{ A}$$

08. **Ans: (c)**

$$\text{Sol: } \frac{1}{s^2 + 1} - I(s) \left(2 + 2s + \frac{1}{s} \right) = 0$$

$$I(s) \left(\frac{2s + 2s^2 + 1}{s} \right) = \frac{1}{s^2 + 1}$$

$$I(s) + 2s^2 I(s) + 2s I(s) = \frac{s}{s^2 + 1}$$

$$i(t) + \frac{2d^2 i}{dt^2} + 2 \frac{di}{dt} = \cos t$$

$$2 \frac{d^2 i}{dt^2} + 2 \frac{di}{dt} + i(t) = \cos t$$

09.

$$\text{Sol: } V = \sqrt{V_R^2 + (V_L - V_C)^2}$$

$$V = V_R = I.R$$

$$100 = I.20; I = 5\text{A}$$

$$\text{Power factor} = \cos \phi = \frac{V_R}{V} = \frac{V_R}{V_R} = 1$$

So, unity power factor.

10.

Sol: By KCL in phasor – domain \Rightarrow

$$-I_1 - I_2 - I_3 = 0$$

$$I_3 = -(I_1 + I_2)$$

$$i_1(t) = \cos(\omega t + 90^\circ)$$

$$I_1 = 1 \angle 90^\circ = j1$$

$$I_2 = 1 \angle 0^\circ = (1 + j0)$$

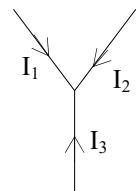



$$I_3 = \sqrt{2} \angle \pi + 45^\circ = \sqrt{2} e^{j(\pi + 45^\circ)}$$

$$i_3(t) = \text{Real part}[I_3 e^{j\omega t}] \text{mA}$$

$$= -\sqrt{2} \cos(\omega t + 45^\circ + \pi) \text{mA}$$

$$i_3(t) = -\sqrt{2} \cos(\omega t + 45^\circ) \text{mA}$$

11.

$$\text{Sol: } I = \frac{V}{R} + \frac{V}{Z_L} + \frac{V}{Z_C} = 8 - j12 + j18$$

$$I = 8 + 6j$$

$$|I| = \sqrt{100} = 10 \text{A}$$

12.

Sol: By KCL \Rightarrow

$$-I + I_L + I_C = 0$$

$$I = I_L + I_C$$

$$I_L = \frac{V}{Z_L} = \frac{V}{j\omega L} = \frac{3\angle 0^\circ}{j(3) \cdot \left(\frac{1}{3}\right)}$$

$$I_L = \frac{3\angle 0^\circ}{j} = \frac{3\angle 0^\circ}{\angle 90^\circ} = 3\angle -90^\circ$$

$$I = 3\angle -90^\circ + 4\angle 90^\circ$$

$$= -j3 + j4 = j1 = 1\angle 90^\circ$$

13. Ans: (d)

Sol:

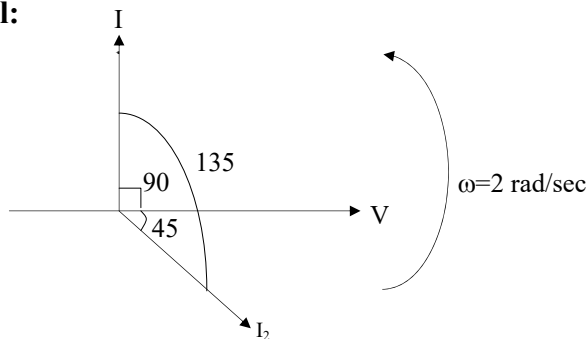

$$I_1 = I_C = \frac{V}{Z_C} = \frac{V}{X_C} \angle 90^\circ$$

$$I_2 = \frac{V}{2 + j\omega L} = \frac{V}{2 + j2} = \frac{V}{2\sqrt{2}} \angle 45^\circ$$

Therefore, the phasor I_1 leads I_2 by an angle of 135°

14.

$$\text{Sol: } I_2 = \sqrt{I_R^2 + I_C^2} \Rightarrow 10 = \sqrt{I_R^2 + 8^2}$$

$$I_R = 6 \text{A}$$

$$I_1 = I = \sqrt{I_R^2 + (I_L - I_C)^2}$$

$$10 = \sqrt{6^2 + (I_L - I_C)^2}$$

$$I_L - I_C = \pm 8 \text{A}$$

$$I_L - 8 = \pm 8$$

$$I_L - 8 = -8 \text{ (Not acceptable)}$$

$$\text{Since } I_L = \frac{V}{Z_L} \neq 0.$$

$$I_L - 8 = 8$$

$$I_L = 16 \text{A}$$

$$I_L > I_C$$

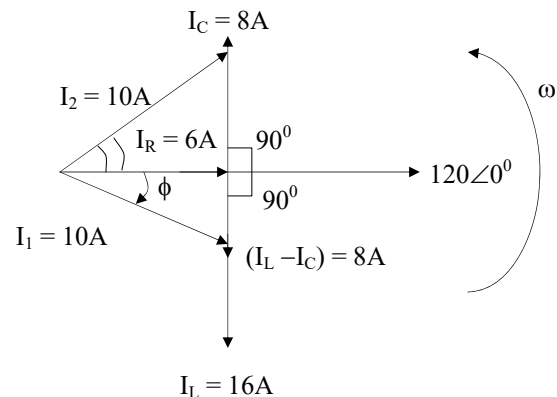

$$I_2 \text{ leads } 120\angle 0^\circ \text{ by } \tan^{-1}\left(\frac{8}{6}\right)$$

$$I_1 \text{ lags } 120\angle 0^\circ \text{ by } \tan^{-1}\left(\frac{8}{6}\right)$$

$$\text{Power factor } \cos\phi = \frac{I_R}{I}$$

$$= \frac{6}{10}$$

$$= 0.6 \text{ (lag)}$$



15.
Sol:

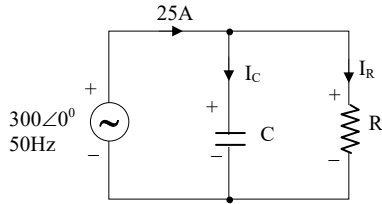

Network is in steady state.

$$|I_C| = \left| \frac{V}{Z_C} \right| = \left| \frac{300\angle 0^\circ}{(1/j\omega C)} \right| = v\omega C$$

$$= 300 \times 2\pi \times 50 \times 159.23 \times 10^{-6}$$

$$I_C = 15A$$

$$I = \sqrt{I_R^2 + I_C^2}$$

$$25 = \sqrt{I_R^2 + 15^2}$$

$$I_R = 20A$$

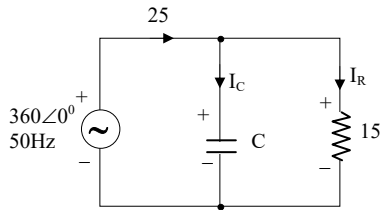

$V_R = RI_R$ By ohm's law

$$300 = R \cdot 20$$

$$R = 15\Omega$$

Network is in steady state

$$I_R = \frac{360}{15} = 24A$$

$$\text{So the required } I_C = \sqrt{25^2 - 24^2}$$

$$v\omega C = 7$$

$$360 \times 2\pi \times f \times 159.23 \times 10^{-6} = 7$$

$$f = 19.4\text{Hz}$$

$$\text{OBS: } I_C = \frac{V}{Z_C}$$

$$Z_C = \frac{1}{j\omega C} \Omega$$

$$\text{As } f \downarrow \Rightarrow Z_C \uparrow \Rightarrow I_C \downarrow$$

16.

Sol: $P_{5\Omega} = 10\text{Watts}$ (Given)

$$= P_{\text{avg}} = I_{\text{rms}}^2 R$$

$$10 = I_{\text{rms}}^2 \cdot 5$$

$$I_{\text{rms}} = \sqrt{2} \text{ A}$$

Power delivered = Power observed
(By Tellegen's Theorem)

$$P_T = I_{\text{rms}}^2 (5 + 10)$$

$$V_{\text{rms}} I_{\text{rms}} \cos\phi = (\sqrt{2})^2 (15)$$

$$\frac{50}{\sqrt{2}} \times \sqrt{2} \cos\phi = 2 \times 15$$

$$\cos\phi = 0.6 \text{ (lag)}$$

17. Ans: (d)

Sol:

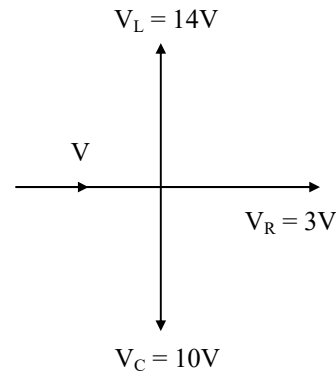

$$V = \sqrt{V_R^2 + (V_L - V_C)^2}$$

$$= \sqrt{(3)^2 + (14 - 10)^2}$$

$$V = 5 \text{ V}$$

18.

$$\text{Sol: } Y = Y_1 + Y_c = \frac{1}{Z_L} + \frac{1}{Z_C}$$

$$= \frac{1}{30\angle 40^\circ} + \frac{1}{\left(\frac{1}{j\omega C}\right)}$$

$$= j\omega C + \frac{1}{30} \angle -40^\circ$$

$$= j\omega C + \frac{1}{30} (\cos 40^\circ - j\sin 40^\circ)$$

Unit power factor $\Rightarrow j$ -term = 0



$$\omega C = \frac{\sin 40^\circ}{30}$$

$$C = \frac{\sin 40^\circ}{2\pi \times 50 \times 30} = 68.1 \mu\text{F}$$

$$C = 68.1 \mu\text{F}$$

19. Ans: (b)

Sol: To increase power factor shunt capacitor is to be placed.

VAR supplied by capacitor

$$\begin{aligned} &= P (\tan\phi_1 - \tan\phi_2) \\ &= 2 \times 10^3 [\tan(\cos^{-1} 0.65) - \tan(\cos^{-1} 0.95)] \\ &= 1680 \text{ VAR} \end{aligned}$$

$$\text{VAR supplied} = \frac{V^2}{X_C} = V^2 \omega C = 1680$$

$$\therefore C = \frac{1680}{(115)^2 \times 2\pi \times 60} = 337 \mu\text{F}$$

20.

$$\text{Sol: } Z = \frac{V}{I} = \frac{160 \angle 10^\circ - 90^\circ}{5 \angle -20^\circ - 90^\circ} = 32 \angle 30^\circ$$

$$\phi = 30^\circ \text{ (Inductive)}$$

$$V_{\text{rms}} = \frac{160}{\sqrt{2}} \text{ V, } I_{\text{rms}} = \frac{5}{\sqrt{2}}$$

$$\begin{aligned} \text{Real power (P)} &= \frac{160}{\sqrt{2}} \times \frac{5}{\sqrt{2}} \times \cos 30^\circ \\ &= 200 \sqrt{3} \text{ W} \end{aligned}$$

$$\begin{aligned} \text{Reactive power (Q)} &= \frac{160}{\sqrt{2}} \times \frac{5}{\sqrt{2}} \times \frac{1}{2} \\ &= 200 \text{ VAR} \end{aligned}$$

$$\begin{aligned} \text{Complex power} &= P + jQ \\ &= 200(\sqrt{3} + j1) \text{ VA} \end{aligned}$$

21.

$$\text{Sol: } V = 4 \angle 10^\circ \text{ and } I = 2 \angle -20^\circ$$

Note: When directly phasors are given the magnitudes are taken as rms values since they are measured using rms meters.

$$V_{\text{rms}} = 4 \text{ V and } I_{\text{rms}} = 2 \text{ A}$$

$$Z = \frac{V}{I} = 2 \angle 30^\circ; \phi = 30^\circ \text{ (Inductive)}$$

$$P = 10 \sqrt{3} \text{ W, } Q = 10 \text{ VAR}$$

$$S = 10(\sqrt{3} + j1) \text{ VA}$$

22. Ans: (a)

$$\begin{aligned} \text{Sol: } S &= VI^* \\ &= (10 \angle 15^\circ)(2 \angle 45^\circ) \\ &= 10 + j17.32 \\ S &= P + jQ \\ P &= 10 \text{ W } Q = 17.32 \text{ VAR} \end{aligned}$$

23. Ans: (c)

$$\begin{aligned} \text{Sol: } P_R &= (I_{\text{rms}})^2 \times R \\ I_{\text{rms}} &= \frac{10}{\sqrt{2}} \end{aligned}$$

$$P_R = \left(\frac{10}{\sqrt{2}}\right)^2 \times 100$$

24.

$$\text{Sol: } P_{\text{avg}} = \frac{V_{\text{rms}}^2}{R} = \frac{\left(\frac{240}{\sqrt{2}}\right)^2}{60} = 480 \text{ Watts}$$

$$V = 240 \angle 0^\circ$$

$$I_R = \frac{V}{R} = \frac{240}{60} = 4 \text{ A}$$

$$I_L = \frac{V}{Z_L} = \frac{V}{X_L} = \frac{240}{40} = 6 \text{ A}$$

$$I_C = \frac{V}{Z_C} = \frac{V}{X_C} = \frac{240}{80} = 3 \text{ A}$$

$I_L > I_C$: Inductive nature of the circuit.

$$I = \sqrt{I_R^2 + (I_L - I_C)^2} = \sqrt{4^2 + 3^2} = 5 \text{ A}$$

$$\text{Power factor} = \frac{I_R}{I} = \frac{4}{5} = 0.8 \text{ (lagging)}$$



25. Ans: (a)

Sol:

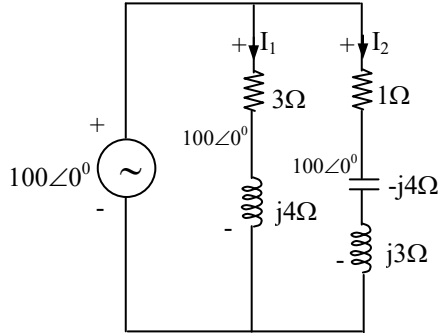

NW is in Steady state.

$$V = 100\angle 0^\circ \Rightarrow V_{\text{rms}} = 100\text{V}$$

$$I_1 = \frac{100\angle 0^\circ}{(3 + j4)\Omega} \Rightarrow |I_1| = 20 = I_{1\text{rms}}$$

$$I_2 = \frac{100\angle 0^\circ}{(1 - j1)\Omega} \Rightarrow |I_2| = \frac{100}{\sqrt{2}} \text{ A} = I_{2\text{rms}}$$

$$P = P_1 + P_2 = (I_{1\text{rms}})^2 \cdot 3 + (I_{2\text{rms}})^2 \cdot 1$$

$$= 20^2 \cdot 3 + \left(\frac{100}{\sqrt{2}}\right)^2 \cdot 1$$

$$P = 6200 \text{ W}$$

$$Q = Q_1 + Q_2$$

$$= (I_{1\text{rms}})^2 \cdot 4 + (I_{2\text{rms}})^2 \cdot (1)$$

$$= 3400\text{VAR}$$

$$\text{So, } S = P + jQ = (6200 + j3400) \text{ VA}$$

26.

Sol:

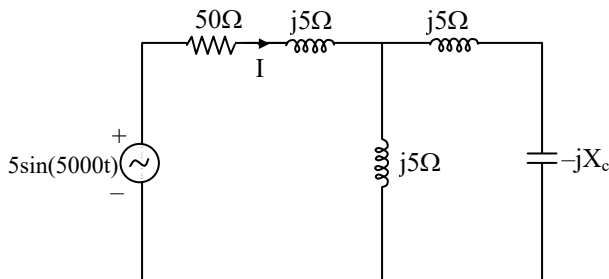
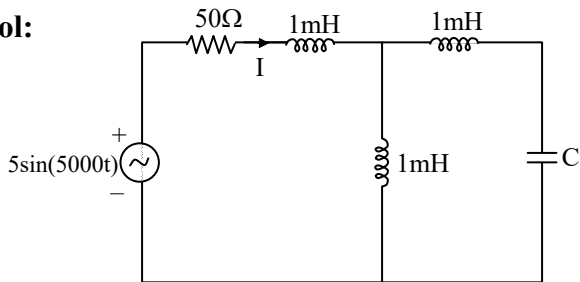

when $I = 0$,

\Rightarrow impedance seen by the source should be infinite

$$\Rightarrow Z = \infty$$

$$\therefore Z = (50 + j5) + (j5) \parallel j(5 - X_c)$$

$$= 50 + j5 + \frac{j5 \times j(5 - X_c)}{j5 + j(5 - X_c)} = \infty$$

$$\Rightarrow j(10 - X_c) = 0$$

$$\Rightarrow X_c = 10 \Rightarrow \frac{1}{\omega C} = 10$$

$$\Rightarrow C = \frac{1}{5000 \times 10} = 20 \mu\text{F}$$

27. Ans: (c)

$$\text{Sol: } I_{\text{rms}} = \sqrt{3^2 + \left(\frac{4}{\sqrt{2}}\right)^2 + \left(\frac{4}{\sqrt{2}}\right)^2}$$

$$= \sqrt{25} = 5 \text{ A}$$

$$\text{Power dissipation} = I_{\text{rms}}^2 R$$

$$= 5^2 \times 10 = 250 \text{ W}$$

28.

Sol: $X_C = X_L \Rightarrow \omega = \omega_0$, the circuit is at resonance

$$V_C = QV_S \angle -90^\circ$$

$$Q = \frac{\omega_0 L}{R} = \frac{X_L}{R} = 2$$

$$= \frac{1}{\omega_0 c R} = \frac{X_C}{R} = 2$$

$$\Rightarrow V_C = 200 \angle -90^\circ = -j200\text{V}$$

29.

Sol: Series RLC circuit

$$f = f_L, \text{ PF} = \cos \phi = 0.707(\text{lead})$$

$$f = f_H, \text{ PF} = \cos \phi = 0.707(\text{lag})$$

$$f = f_0, \text{ PF} = \cos \phi = 1$$



30. Ans: (b)

Sol: Network is in steady state (since no switch is given)

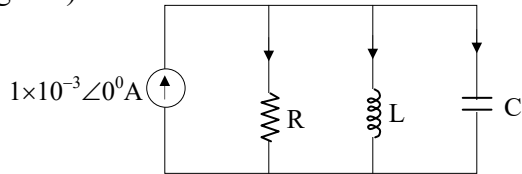

Let $I = 1 \text{ mA}$

$\omega = \omega_0$ (Given)

$\Rightarrow I_R = I$

$I_L = QI \angle -90^\circ = -jQI$

$I_C = QI \angle 90^\circ = jQI$

$I_L + I_C = 0$

$$|I_R + I_L| = |I - jQI|$$

$$= I\sqrt{1 + Q^2} > I$$

$$|I_R + I_C| = |I + jQI|$$

$$= I\sqrt{1 + Q^2} > I$$

31. Ans: (c)

Sol: Since, "I" leads voltage, therefore capacitive effect and hence the operating frequency ($f < f_0$)

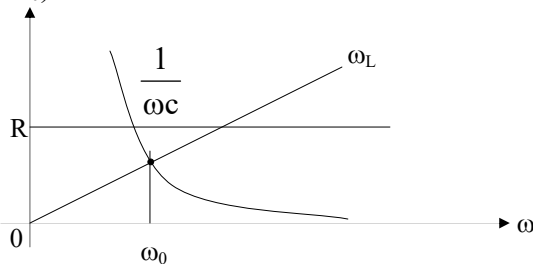

32.

Sol:
$$Y = \frac{1}{R_L + j\omega L} + \frac{1}{R_C - \frac{j}{\omega C}}$$

$$= \frac{R_L - j\omega L}{R_L^2 + (\omega L)^2} + \frac{R_C + j/\omega C}{R_C^2 + (1/\omega C)^2}$$

j - term $\Rightarrow 0$

$$\omega_0 = \frac{1}{\sqrt{LC}} \sqrt{\frac{R_L^2 - \frac{L}{C}}{R_C^2 - \frac{L}{C}}} \text{ rad/sec}$$

33.

Sol:

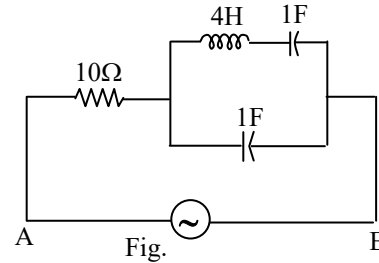

The given circuit is shown in Fig.

$$Z_{AB} = 10 + Z_1$$

where, $Z_1 = \left(\frac{-j}{\omega} \right) \parallel \left(j4\omega - \frac{j}{\omega} \right)$

$$= \frac{\left(\frac{-j}{\omega} \right) \left(j4\omega - \frac{j}{\omega} \right)}{\frac{-j}{\omega} + j4\omega - \frac{j}{\omega}}$$

$$= \frac{4 - \frac{1}{\omega^2}}{j4\omega - \frac{j2}{\omega}}$$

For circuit to be resonant i.e., $\omega^2 = \frac{1}{4}$

$$\omega = \frac{1}{2} = 0.5 \text{ rad/sec}$$

$$\therefore \omega_{\text{resonance}} = 0.5 \text{ rad/sec}$$

34.

Sol: (i) $\frac{L}{C} = R^2 \Rightarrow$ circuit will resonate for all the frequencies, out of infinite number of frequencies we are selecting one frequency.



$$\text{i.e., } \omega_0 = \frac{1}{\sqrt{LC}} = \frac{1}{2} \text{ rad/sec}$$

$$\text{then } Z = R = 2\Omega.$$

$$I = \frac{V}{Z} = \frac{10\angle 0^\circ}{2} = 5\angle 0^\circ$$

$$i(t) = 5\cos\left(\frac{t}{2}\right) \text{ A}$$

$$Z_L = j\omega_0 L = j2\Omega ; Z_C = \frac{1}{j\omega_0 C} = -j2\Omega.$$

$$I_L = \frac{I(2-j2)}{2+j2+2-j2} = \frac{I}{\sqrt{2}} \angle -45^\circ$$

$$i_L = \frac{5}{\sqrt{2}} \cos\left(\frac{t}{2} - 45^\circ\right) \text{ A}$$

$$i_c = \frac{I(2+j2)}{2+j2+2-j2} = \frac{I}{\sqrt{2}} \angle 45^\circ$$

$$i_c = \frac{5}{\sqrt{2}} \cos\left(\frac{t}{2} + 45^\circ\right) \text{ A}$$

$$\begin{aligned} P_{\text{avg}} &= I_{L(\text{rms})}^2 \cdot R + I_{C(\text{rms})}^2 \cdot R \\ &= \left(\frac{5/\sqrt{2}}{\sqrt{2}}\right)^2 \cdot 2 + \left(\frac{5/\sqrt{2}}{\sqrt{2}}\right)^2 \cdot 2 \\ &= 25 \text{ watts} \end{aligned}$$

(ii) $\frac{L}{C} \neq R^2$ circuit will resonate at only one frequency.

$$\text{i.e., at } \omega_0 = \frac{1}{\sqrt{LC}} = \frac{1}{4} \text{ rad/sec}$$

$$\text{Then } Y = \frac{2R}{R^2 + \frac{L}{C}} \text{ mho}$$

$$Y = \frac{2(2)}{2^2 + \frac{4}{4}} = \frac{4}{5} \text{ mho}$$

$$Z = \frac{5}{4} \Omega$$

$$I = \frac{V}{Z} = \frac{10\angle 0^\circ}{5/4} = 8\angle 0^\circ$$

$$i(t) = 8\cos\left(\frac{t}{4}\right) \text{ A}$$

$$Z_L = j\omega_0 L = j1\Omega$$

$$Z_C = \frac{1}{j\omega_0 C} = -j1\Omega$$

$$I_L = \frac{I(2-j1)}{2+j1+2-j1} = \frac{\sqrt{5}}{4} I \angle \tan^{-1}\left(\frac{1}{2}\right)$$

$$i_L = \frac{8\sqrt{5}}{4} \cos\left(\frac{t}{4} - \tan^{-1}\left(\frac{1}{2}\right)\right)$$

$$I_c = \frac{I(2+j1)}{2+j1+2-j1} = \frac{\sqrt{5}}{4} I \angle \tan^{-1}\left(\frac{1}{2}\right)$$

$$i_c = \frac{8\sqrt{5}}{4} \cos\left(\frac{t}{4} + \tan^{-1}\left(\frac{1}{2}\right)\right)$$

$$\begin{aligned} P_{\text{avg}} &= I_{L(\text{rms})}^2 \cdot R + I_{C(\text{rms})}^2 \cdot R \\ &= \left(\frac{2\sqrt{5}}{\sqrt{2}}\right)^2 \cdot 2 + \left(\frac{2\sqrt{5}}{\sqrt{2}}\right)^2 \cdot 2 \\ &= 40 \text{ Watts} \end{aligned}$$

35.

$$\begin{aligned} \text{Sol: (i) } Z_{\text{ab}} &= 2 + (Z_L \parallel Z_C \parallel 2) \\ &= 2 + jX_L \parallel -jX_C \parallel 2 \\ &= \frac{2 + 2X_L X_C (X_L X_C - j2(X_L - X_C))}{(X_L X_C)^2 + 4(X_L - X_C)^2} \end{aligned}$$

$$j\text{-term} = 0$$

$$\Rightarrow -2(X_L - X_C) = 0$$

$$X_L = X_C$$

$$\omega_0 L = \frac{1}{\omega_0 C}$$

$$\omega_0 = \frac{1}{\sqrt{LC}} = \frac{1}{\sqrt{4.4}} = \frac{1}{4} \text{ rad/sec}$$

At resonance entire current flows through 2Ω only.

$$\text{(ii) } Z_{\text{ab}} \Big|_{\omega=\omega_0} = 2 + 2 = 4\Omega$$

$$X_L = X_C$$

$$\text{(iii) } V_i(t) = V_m \sin\left(\frac{t}{4}\right) \text{ V}$$



$$Z = 4\Omega$$

$$i(t) = \frac{V_i(t)}{Z} = \frac{V_m}{4} \sin\left(\frac{t}{4}\right) = i_R$$

$$V = 2i_R = \frac{V_m}{2} \sin\left(\frac{t}{4}\right) V = V_C = V_L$$

$$i_C = C \frac{dV_C}{dt} = \frac{V_m}{2} \cos\left(\frac{t}{4}\right)$$

$$i_C = \frac{V_m}{2} \sin\left(\frac{t}{4} + 90^\circ\right) A$$

$$i_L = \frac{1}{L} \int V_L \cdot dt$$

$$= -\frac{V_m}{2} \cos\left(\frac{t}{4}\right)$$

$$i_L = \frac{V_m}{2} \sin\left(\frac{t}{4} - 90^\circ\right) A$$

OBS: Here $i_L + i_C = 0$
 \Rightarrow LC Combination is like an open circuit.

36. Ans: (d)

Sol:

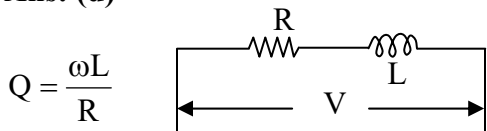

$$Q = \frac{\omega L}{R}$$

$$Q = \frac{2\omega L}{R} = 2 \times \text{original} \rightarrow Q - \text{doubled}$$

$$S = V \cdot I$$

$$= V \cdot \frac{V}{R + j\omega L} \times \frac{R - j\omega L}{R - j\omega L}$$

$$S = \frac{V^2}{R^2 + (\omega L)^2} - \frac{V^2 \cdot j\omega L}{R^2 + (\omega L)^2}$$

$$S = P + jQ$$

$$\text{Active power (P)} = \frac{V^2}{R^2 + (\omega L)^2}$$

$$P = \frac{V^2}{R^2(1 + Q^2)}$$

$$P \approx \frac{V^2}{R^2 Q^2}$$

as Q is doubled, P decreases by four times.

37.

Sol: $Z_C = \frac{1}{j\omega C}$

$$\omega = 0; Z_C = \infty \Rightarrow C : \text{open circuit} \Rightarrow i_2 = 0$$

$$\omega = \infty; Z_C = 0 \Rightarrow C : \text{Short Circuit} \Rightarrow i_2 = \frac{E_m \angle 0^\circ}{R_2}$$

Transform the given network into phasor domain.

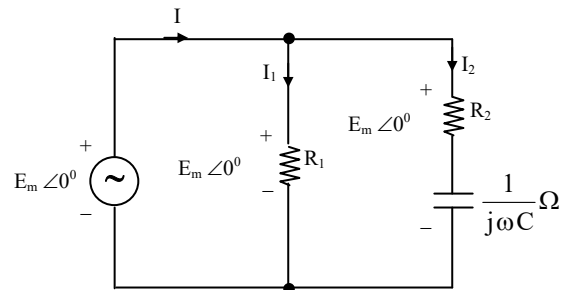

Network is in phasor domain.

By KCL in P-d $\Rightarrow I = I_1 + I_2$

$$I_1 = \frac{E_m \angle 0^\circ}{R_1}$$

$$I_2 = \frac{E_m \angle 0^\circ}{R_2 + \frac{1}{j\omega C}} = \frac{E_m \angle 0^\circ}{R_2 - \frac{j}{\omega C}}$$

$$I_2 = \frac{E_m \angle \tan^{-1}\left(\frac{1}{\omega C R_2}\right)}{\sqrt{R^2 + \left(\frac{1}{\omega C}\right)^2}}$$

$$\omega = \infty \Rightarrow I_2 = \frac{E_m \angle 0^\circ}{R_2}$$

$$\omega = 0 \Rightarrow I_2 = 0A$$

$\omega : (0 \text{ and } \infty)$ j the current phasor I_2 will always lead the voltage $E_m \angle 0^\circ$.

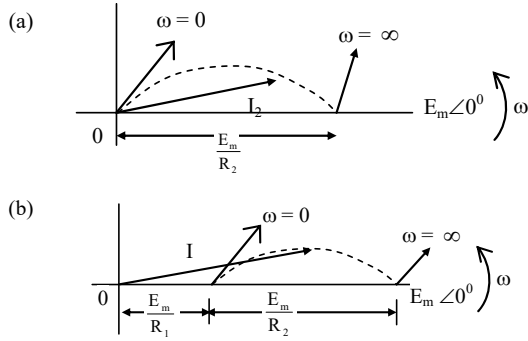

38.

Sol: $R_2 = 0 \Rightarrow I_2 = \frac{E_m \angle 0^\circ}{0 + \frac{1}{j\omega C}} = E_m \omega C \angle 90^\circ$

$R_2 = \infty \Rightarrow I_2 = 0 \text{ A}$

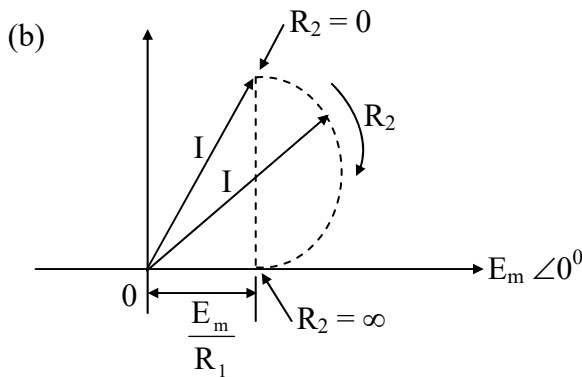
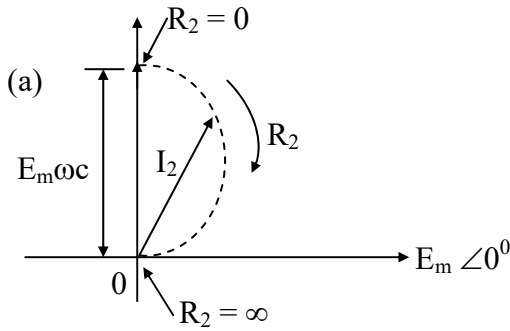

39.

Sol: $I = I_1 + I_2$; $I_1 = \frac{E_m \angle 0^\circ}{R_1}$

$I_2 = \frac{E_m \angle 0^\circ}{R_2 + j\omega L} = \frac{E_m}{\sqrt{R_2^2 + (\omega L)^2}} \angle -\tan^{-1}\left(\frac{\omega L}{R_2}\right)$

(i) If " ω " Varied

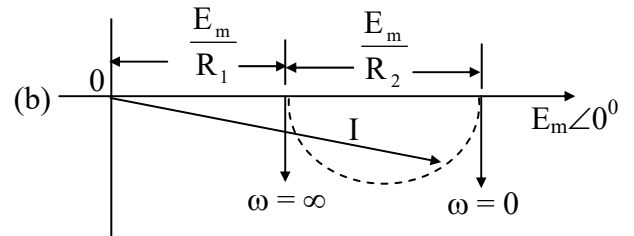
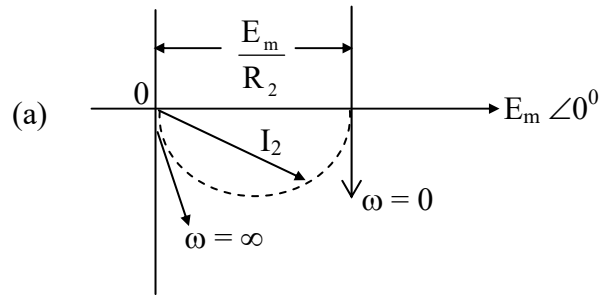

(ii) If " R_2 " is varied

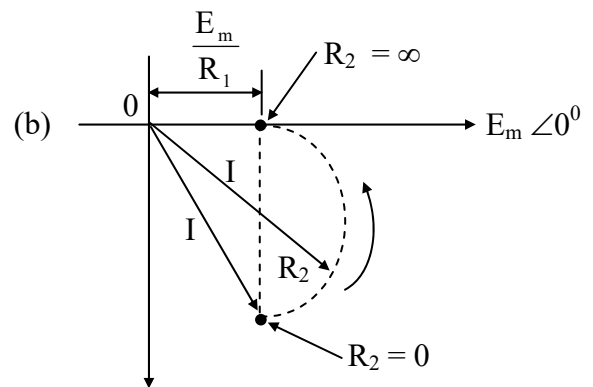
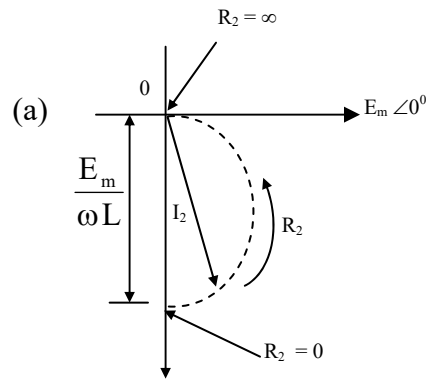

Class Room Practice Solutions

01.

Sol: $X_C = 12$ (Given) $X_{eq} = 12$ (must for series resonance)

So the dot in the second coil at point "Q"

$$L_{eq} = L_1 + L_2 - 2M$$

$$L_{eq} = L_1 + L_2 - 2K\sqrt{L_1 L_2}$$

$$\omega L_{eq} = \omega L_1 + \omega L_2 - 2K\sqrt{\omega L_1 \omega L_2}$$

$$12 = 8 + 8 - 2K\sqrt{8 \cdot 8} \Rightarrow K = 0.25$$

02.

Sol: $X_C = 14$ (Given) $X_{Leq} = 14$ (must for series resonance)So the dot in the 2nd coil at "P"

$$L_{eq} = L_1 + L_2 + 2M$$

$$L_{eq} = L_1 + L_2 + K\sqrt{L_1 L_2}$$

$$\omega L_{eq} = \omega L_1 + \omega L_2 + 2K\sqrt{\omega L_1 \omega L_2}$$

$$14 = 2 + 8 + 2K\sqrt{2(8)} \Rightarrow K = 0.5$$

03.

Sol: $L_{ab} = 4H + 2 - 2 + 6H + 2 - 2 + 8H - 2 - 2$

$$L_{ab} = 14H$$

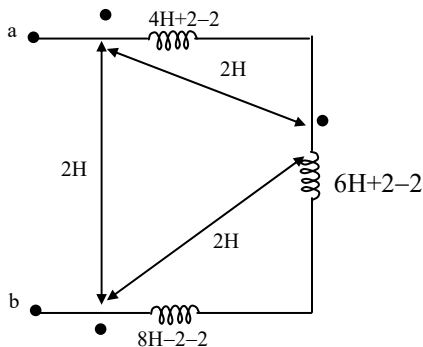
04. **Ans:** (c)**Sol:** Impedance seen by the source

$$\begin{aligned} Z_s &= \frac{Z_L}{16} + (4 - j2) \\ &= \frac{10 \angle 30^\circ}{16} + (4 - j2) \\ &= 4.54 - j1.69 \end{aligned}$$

05.

$$\text{Sol: } Z_{in} = \left(\frac{N_1}{N_2} \right)^2 \cdot Z_L$$

$$R'_{in} = n^2 \cdot 5$$

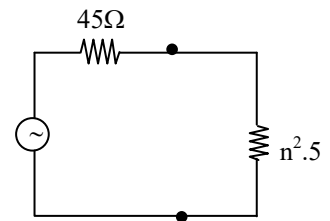
For maximum power transfer; $R_L = R_s$

$$n^2 \cdot 5 = 45 \Rightarrow n = 3$$

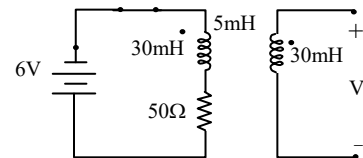
06. **Ans:** (b)**Sol:**

Apply KVL at input loop

$$-6 - 30 \times 10^{-3} \frac{di_1}{dt} + 5 \times 10^{-3} \frac{di_2}{dt} - 50i_1 = 0 \dots (1)$$

Take Laplace transform

$$-\frac{6}{s} + [-30 \times 10^{-3}(s) - 50]I_1(s) + 5 \times 10^{-3} s I_2(s) = 0 \dots (2)$$

Apply KVL at output loop

$$V_2(s) - 30 \times 10^{-3} \frac{di_2}{dt} + 5 \times 10^{-3} \frac{di_1}{dt} = 0$$

Take Laplace transform

$$V_2(s) - 30 \times 10^{-3} s I_2(s) + 5 \times 10^{-3} s I_1(s) = 0$$

Substitute $I_2(s) = 0$ in above equation

$$V_2 + 5 \times 10^{-3} s I_1(s) = 0 \dots (3)$$



From equation (2)

$$-\frac{6}{s} + (-30 \times 10^{-3}(s) + 50)I_1(s) = 0$$

$$I_1(s) = \frac{-6}{s(30 \times 10^{-3}(s) + 50)} \dots\dots\dots (4)$$

Substitute eqn (4) in eqn (3)

$$V_2(s) = \frac{-5 \times 10^{-3}(s)(-6)}{s(30 \times 10^{-3}(s) + 50)}$$

Apply Initial value theorem

$$\lim_{s \rightarrow \infty} s \frac{-5 \times 10^{-3}(s)(-6)}{s(30 \times 10^{-3}(s) + 50)}$$

$$v_2(t) = \frac{-5 \times 10^{-3} \times (-6)}{30 \times 10^{-3}} = +1$$

07.

Sol: $R_{in}' = \frac{8}{2^2} = 2\Omega$

$$R_{in} = 3 + R_{in}' = 3 + 2 = 5\Omega$$

$$I_1 = \frac{10 \angle 20^\circ}{5} = 2 \angle 20^\circ$$

$$\frac{I_1}{I_2} = n = 2$$

$$\Rightarrow I_2 = 1 \angle 20^\circ \text{A}$$

08.

Sol: Transform the above network into phasor domain

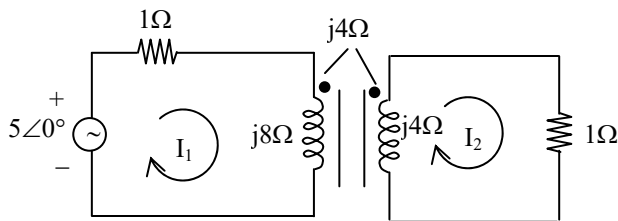

Network is in Phasor -domain

$$V = Z.I$$

By KVL in p-d \Rightarrow

$$5 \angle 0^\circ = I_1 + j8.I_1 - j4.I_2$$

$$0 = I_2 + j4I_2 - j4I_1$$

$$I_1 = \frac{\Delta_1}{\Delta}; i_1(t) = \text{Re al part} [I_1 e^{j2t}] \text{A}$$

$$I_2 = \frac{\Delta_2}{\Delta}; i_2(t) = \text{Re al part} [I_2 . e^{j2t}] \text{A}$$

$$I_1(t) = 1.072 \cos (2t + 114.61^\circ) \text{A}$$

$$I_2(t) = 1.416 \cos (2t + 128.65^\circ) \text{A}$$

09.

Sol: Evaluation of Initial conditions:

$$i_1(0^-) = 0 \text{A} = i_1(0^+)$$

$$i_2(0^-) = 0 \text{A} = i_2(0^+)$$

Evaluation of final conditions:

$$i_1(\infty) = 5 \text{A} \quad ; \quad i_2(\infty) = 0 \text{A}$$

By KVL \Rightarrow

$$5 = i_1(t) + \frac{4di_1(t)}{dt} - 2 \frac{di_2(t)}{dt}$$

By Laplace transform to the above equations.

$$\frac{5}{s} = I_1(s) + 4[sI_1(s) - i_1(0^+)] - 2[sI_2(s) - i_2(0^+)]$$

By KVL \Rightarrow

$$0 = 1.i_2(t) + 2 \frac{di_2(t)}{dt} - 2 \frac{di_1(t)}{dt}$$

$$0 = 1.I_2(s) + 2[sI_2(s) - i_2(0^+)] - [sI_1(s) - i_1(0^+)]$$

On solving, we can obtain $i_1(t)$ and $i_2(t)$

$$i_1(t) = 5 - e^{-\frac{3t}{4}} \left[5 \cosh\left(\frac{\sqrt{5}}{4}t\right) - \sqrt{5} \sinh\left(\frac{\sqrt{5}}{4}t\right) \right] \text{A}$$

10.

Sol: By the definition of KVL in phasor domain

$$V_s - V_0 - V_2 = 0$$

$$V_0 = V_s - V_2 = V_s \left(1 - \frac{V_2}{V_s} \right)$$

$$V = ZI$$

By KVL

$$V_s = j\omega L_1 . I_1 + j\omega M(0)$$

$$V_2 = j\omega L_2(0) + j\omega M I_1$$

$$V_0 = V_s \left(1 - \frac{M}{L_1} \right)$$

Class Room Practice Solutions

01.

Sol: The defining equations for open circuit impedance parameters are:

$$V_1 = Z_{11}I_1 + Z_{12}I_2$$

$$V_2 = Z_{21}I_1 + Z_{22}I_2$$

$$[Z] = \begin{bmatrix} \frac{10}{s} & \frac{4s+10}{s} \\ \frac{s}{10} & \frac{s}{3s+10} \end{bmatrix} \Omega$$

02. Ans: (b)

Sol: The matrix given is $\begin{bmatrix} 0 & -1 \\ \frac{1}{2} & \frac{1}{2} \end{bmatrix} = \begin{bmatrix} y_{11} & y_{12} \\ y_{21} & y_{22} \end{bmatrix}$

since $y_{11} \neq y_{22}$

\Rightarrow Asymmetrical, and

$Y_{12} \neq Y_{21}$

\Rightarrow Non reciprocal network

03.

Sol: Convert Y to Δ :

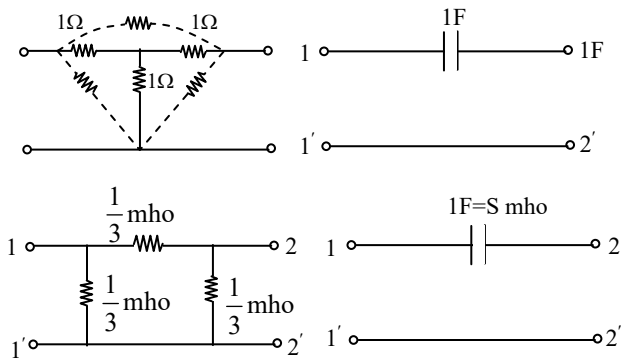

Fig:A

Fig:B

$$Y_A = \begin{bmatrix} \frac{2}{3} & -\frac{1}{3} \\ -\frac{1}{3} & \frac{2}{3} \end{bmatrix}$$

$$Y_B = \begin{bmatrix} S & -S \\ -S & S \end{bmatrix}$$

$$Y = \begin{bmatrix} S + \frac{2}{3} & -S - \frac{1}{3} \\ -S - \frac{1}{3} & S + \frac{2}{3} \end{bmatrix} \text{mho}$$

04.

Sol:

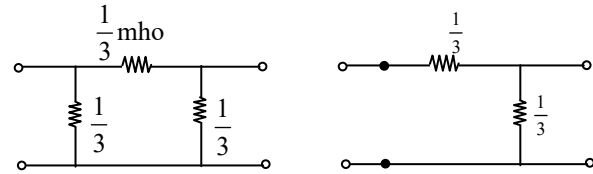
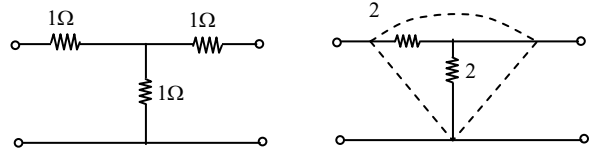

$$Y_A = \begin{bmatrix} \frac{2}{3} & -\frac{1}{3} \\ -\frac{1}{3} & \frac{2}{3} \end{bmatrix} \quad Y_B = \begin{bmatrix} \frac{1}{3} & -\frac{1}{3} \\ -\frac{1}{3} & \frac{2}{3} \end{bmatrix}$$

$$Y = \begin{bmatrix} 1 & -\frac{2}{3} \\ -\frac{2}{3} & \frac{4}{3} \end{bmatrix}$$

05.

Sol: Convert Y to Δ :

Convert Y to Δ :

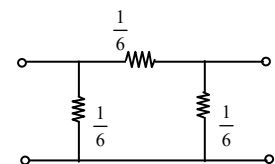
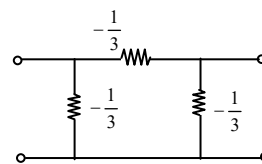
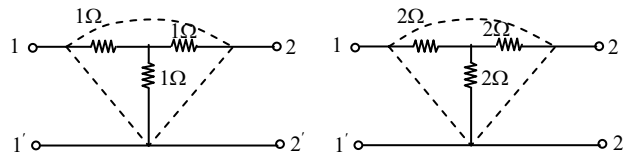



$$Y_A = \begin{bmatrix} \frac{2}{3} & -\frac{1}{3} \\ -\frac{1}{3} & \frac{2}{3} \end{bmatrix} \text{ mho} \quad Y_B = \begin{bmatrix} \frac{2}{6} & -\frac{1}{6} \\ -\frac{1}{6} & \frac{2}{6} \end{bmatrix} \text{ mho}$$

$$Y = \begin{bmatrix} \frac{6}{6} & -\frac{3}{6} \\ -\frac{3}{6} & \frac{6}{6} \end{bmatrix} = \begin{bmatrix} 1 & -\frac{1}{2} \\ -\frac{1}{2} & 1 \end{bmatrix}$$

06. Sol:

$$T_1 = T_2 = \begin{bmatrix} 1 + \frac{1}{-j1} & 1 \\ \frac{1}{-j1} & 1 \end{bmatrix}$$

$$= \begin{bmatrix} 1 + j & 1 \\ j & 1 \end{bmatrix}$$

$T_3 \Rightarrow Z_1 = 1\Omega; Z_2 = \infty$

$$T_3 = \begin{bmatrix} 1 & 1 \\ 0 & 1 \end{bmatrix}$$

$T = (T_1)(T_2)(T_3)$

$$T = \begin{bmatrix} j3 & 2 + j4 \\ -1 + j2 & j3 \end{bmatrix}$$

07.

Sol: $T_1 : Z = \begin{bmatrix} 2 & 1 \\ 1 & 2 \end{bmatrix}$

$$T_1 = \begin{bmatrix} 2 & 3 \\ 1 & 2 \end{bmatrix}$$

$T_2 : Z_1 = 0; Z_2 = 2\Omega$

$$T_2 = \begin{bmatrix} 1 & 0 \\ \frac{1}{2} & 1 \end{bmatrix}$$

$T = [T_1] [T_2]$

$$T = \begin{bmatrix} 3.5 & 3 \\ 2 & 2 \end{bmatrix}$$

08. Ans: (a)

Sol: For $I_2 = 0$ (O/P open), the Network is shown in Fig.1

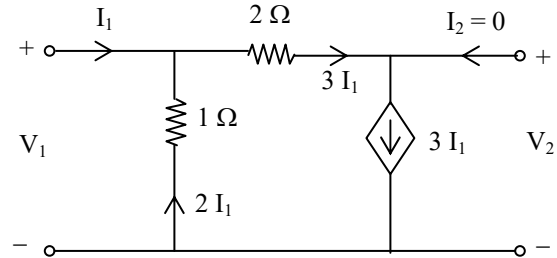

Fig. 1

$V_1 = -2 I_1 \dots\dots\dots (1)$

$Z_{11} = \frac{V_1}{I_1} = -2$

$V_2 = -6 I_1 + V_1 \dots\dots\dots (2)$

From (1) and (2)

$V_2 = -6 I_1 - 2 I_1$

or $V_2 = -8 I_1$

$Z_{21} = \frac{V_2}{I_1} = -8$

For $I_1 = 0$ (I/P open), the network is shown in Fig.2

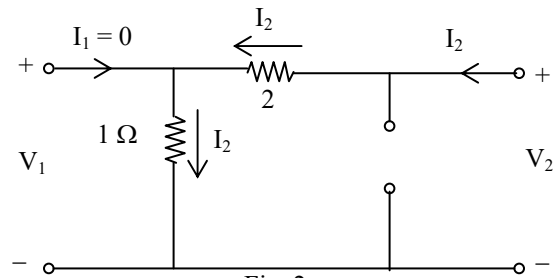

Fig. 2

Note: that the dependent current source with current $3 I_1$ is open circuited.

$V_1 = 1 I_2, \quad Z_{12} = \frac{V_1}{I_2} = 1$

$V_2 = 3 I_2, \quad Z_{22} = \frac{V_2}{I_2} = 3$

$$[Z] = \begin{bmatrix} -2 & 1 \\ -8 & 3 \end{bmatrix}$$



09.

Sol: By Nodal

$$-I_1 + V_1 - 3V_2 + V_1 + 2V_1 - V_2 = 0$$

$$-I_2 + V_2 + V_2 - 2V_1 = 0$$

$$Y = \begin{bmatrix} 4 & -4 \\ -3 & 2 \end{bmatrix} \mathcal{U}$$

$$[Z] = Y^{-1}$$

We can also obtain [g], [h], [T] and [T]⁻¹ by re-writing the equations.

10.

Sol: The defining equations for open-circuit impedance parameters are:

$$V_1 = Z_{11}I_1 + Z_{12}I_2$$

$$V_2 = Z_{21}I_1 + Z_{22}I_2$$

In this case, the individual Z-parameter matrices get added.

$$(Z) = (Z_a) + (Z_b)$$

$$[Z] = \begin{bmatrix} 10 & 2 \\ 2 & 7 \end{bmatrix} \Omega$$

11.

Sol: For this case the individual y-parameter matrices get added to give the y-parameter matrix of the overall network.

$$Y = Y_a + Y_b$$

The individual y-parameters also get added

$$Y_{11} = Y_{11a} + Y_{11b} \text{ etc}$$

$$[Y] = \begin{bmatrix} 1.4 & -0.4 \\ -0.4 & 1.4 \end{bmatrix} \text{mho}$$

12. **Ans: (c)**

$$\text{Sol: } Y_{11} = \frac{I_1}{V_1} \Big|_{V_2=0}$$

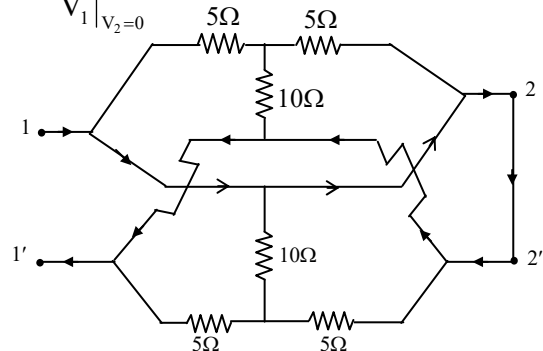

$$Y_{11} = \frac{I_1}{0} = \infty$$

13.

$$\text{Sol. (i). } [T_a] = \begin{bmatrix} 1 + \frac{Z_1}{Z_2} & Z_1 \\ \frac{1}{Z_2} & 1 \end{bmatrix}$$

$$\text{(ii). } [T_a] = \begin{bmatrix} 1 & Z_1 \\ \frac{1}{Z_2} & 1 + \frac{Z_1}{Z_2} \end{bmatrix}$$

[T_a] and [T_b] are obtained by defining equations for transmission parameters.

14.

Sol: In this case, the individual T-matrices get multiplied

$$(T) = (T_1) \times (T_{N1})$$

$$(T) = (T_1)(T_{N1}) = \begin{pmatrix} 1+s/4 & s/2 \\ 1/2 & 1 \end{pmatrix} \begin{pmatrix} 8 & 4 \\ 2 & 5 \end{pmatrix} \\ = \begin{pmatrix} 3s+8 & 3.5s+4 \\ 6 & 7 \end{pmatrix}$$

15.

$$\text{Sol: } Z_{in} = R_{in} = \frac{V_1}{I_1} = \frac{AV_2 - BI_2}{CV_2 - DI_2} = \frac{V_2 - 2I_2}{V_2 - 3I_2},$$

$$V_2 = 10(-I_2)$$

$$Z_{in} = R_{in} = \frac{12}{13} \Omega$$



16.

Sol: $\left. \frac{V_1}{I_1} \right|_{I_2=0} = Z_{11}$

$\Rightarrow V_1 = (4 \parallel 4) I_1 |_{I_2=0}$

$\Rightarrow Z_{11} = 2\Omega$

$V_2 = (4 \parallel 4) I_2 |_{I_1=0}$

$\Rightarrow Z_{22} = 2\Omega$

By KVL \Rightarrow

$\frac{3I_1}{2} - V_2 - \frac{I_1}{2} = 0$

$V_2 = I_1$

$\Rightarrow Z_{21} = 1\Omega = Z_{12}$

$Z = \begin{bmatrix} 2 & 1 \\ 1 & 2 \end{bmatrix} \Omega$

$Y = Z^{-1} = \begin{bmatrix} \frac{2}{3} & \frac{-1}{3} \\ \frac{-1}{3} & \frac{2}{3} \end{bmatrix} \text{S}$

Now [T] parameters;

$V_1 = 2I_1 + I_2 \dots\dots\dots (1)$

$V_2 = I_1 + 2I_2 \dots\dots\dots (2)$

$\Rightarrow I_1 = V_2 - 2I_2 \dots\dots\dots (3)$

Substituting (3) in (1):

$V_1 = 2(V_2 - 2I_2) + I_2 = 2V_2 - 3I_2 \dots\dots\dots (4)$

$T = \begin{bmatrix} 2 & 3 \\ 1 & 2 \end{bmatrix}$

$T^{-1} = T^{-1} = \begin{bmatrix} 2 & -3 \\ -1 & 2 \end{bmatrix}$

Now h parameters

$2I_2 = -I_1 + V_2$

$I_2 = \frac{-I_1}{2} + \frac{V_2}{2} \dots\dots\dots (5)$

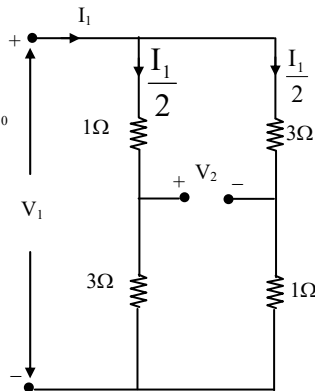

Substitute (5) in (1)

$V_1 = 2I_1 \frac{-I_1}{2} + \frac{V_2}{2}$

$V_1 = \frac{3}{2} I_1 + \frac{1}{2} V_2 \dots\dots\dots (6)$

$h = \begin{bmatrix} \frac{3}{2} & \frac{1}{2} \\ \frac{-1}{2} & \frac{1}{2} \end{bmatrix}$

$g = [h]^{-1} = \begin{bmatrix} \frac{1}{2} & -1 \\ \frac{1}{2} & \frac{3}{2} \end{bmatrix}$

17. Ans: (a)

Sol: $Y_{22} = \left. \frac{I_2}{V_2} \right|_{V_1=0}$

just use reciprocity of fig (a)

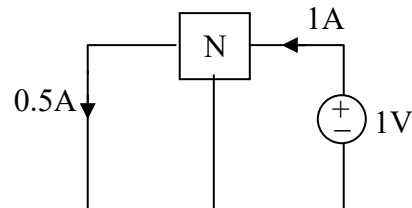

Now use Homogeneity

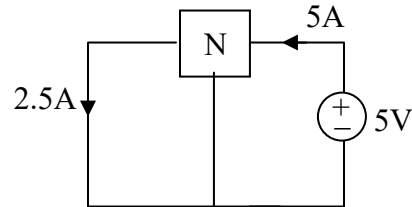

So, $Y_{22} = \left. \frac{I_2}{V_2} \right|_{V_1=0}$

$= \frac{5}{5} = 1 \text{ mho}$

This has nothing to do with fig (b) since fig (b) also valid for some specific resistance of 2 Ω at port-1, but $Y_{22}, V_1 = 0$. So S.C port-1



18.

Sol: $\frac{V_2}{V_1} = \frac{N_2}{N_1} = n = \frac{-I_1}{I_2}$

$$\frac{V_2}{V_1} = n$$

$$\Rightarrow V_1 = \frac{1}{n} V_2 - (0)I_2$$

$$\Rightarrow T = \begin{bmatrix} \frac{1}{n} & 0 \\ 0 & n \end{bmatrix}$$

$$T^1 = T^{-1} = \begin{bmatrix} n & 0 \\ 0 & \frac{1}{n} \end{bmatrix}$$

$$T^1 = T^{-1} = \begin{bmatrix} n & 0 \\ 0 & \frac{1}{n} \end{bmatrix}$$

Now h-parameters

$$V_1 = (0)I_1 + \frac{1}{n} V_2$$

$$I_2 = \frac{-I_1}{n} + (0)V_2$$

$$h = \begin{bmatrix} 0 & \frac{1}{n} \\ \frac{-1}{n} & 0 \end{bmatrix}$$

$$g = \begin{bmatrix} 0 & -n \\ n & 0 \end{bmatrix}$$

Note: In an ideal transformer, it is impossible to express V_1 and V_2 in terms of I_2 and I_1 , hence the 'Z' parameters do not exist. Similarly, the y-parameters.

19. Ans: (c)

Sol: $Z_{22} = \frac{V_2}{I_2} \Big|_{V_1=0}$

$$\frac{V_1}{V_2} = \frac{1}{n} = \frac{I_2}{I_1}$$

$$V_1 = \frac{1}{n} V_2$$

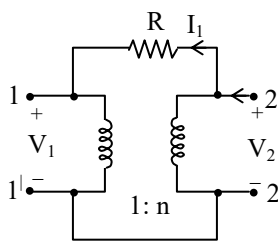

$$\frac{V_2 - V_1}{R} = I_1$$

$$I_2^1 = I_2 + I_1$$

$$\frac{1}{n} = \frac{I_2}{I_1} = \frac{I_2^1 - I_1}{I_1} = \frac{I_2^1}{I_1} - 1$$

$$\frac{I_2^1}{I_1} = \frac{1}{n} + 1 = \frac{1+n}{n}$$

$$I_2^1 = \left(\frac{1+n}{n}\right) I_1$$

$$I_2^1 = \left(\frac{1+n}{n}\right) \left(\frac{V_2 - V_1}{R}\right)$$

$$I_2^1 = \left(\frac{1+n}{n}\right) \left(\frac{V_2 - \frac{1}{n} V_2}{R}\right)$$

$$\frac{I_2^1}{V_2} = \left(\frac{1+n}{n}\right) \left(\frac{n-1}{nR}\right)$$

$$\frac{V_2}{I_2^1} = \frac{n^2 R}{n^2 - 1}$$

20.

Sol:

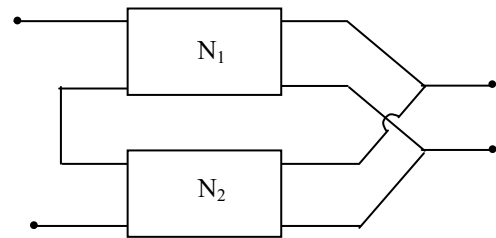

For series parallel connection individual h-parameters can be added.

∴ For network 1,

$$h_1 = g_1^{-1}$$

$$= \begin{bmatrix} 1 & 0 \\ 1 & 1 \end{bmatrix}^{-1}$$

$$= \begin{bmatrix} 1 & 0 \\ -1 & 1 \end{bmatrix}$$



For network 2,

$$h_2 = g_2^{-1}$$

$$= \begin{bmatrix} 1 & 1 \\ 0 & 1 \end{bmatrix}^{-1}$$

$$= \begin{bmatrix} 1 & -1 \\ 0 & 1 \end{bmatrix}$$

$$\therefore h = \begin{bmatrix} 1 & 0 \\ -1 & 1 \end{bmatrix} + \begin{bmatrix} 1 & -1 \\ 0 & 1 \end{bmatrix}$$

$$= \begin{bmatrix} 2 & -1 \\ -1 & 2 \end{bmatrix}$$

\therefore overall g-parameters,

$$g = h^{-1}$$

$$= \begin{bmatrix} 2 & -1 \\ -1 & 2 \end{bmatrix}^{-1}$$

$$= \frac{1}{3} \begin{bmatrix} 2 & 1 \\ 1 & 2 \end{bmatrix}$$

$$g = \begin{bmatrix} 2/3 & 1/3 \\ 1/3 & 2/3 \end{bmatrix}$$

Class Room Practice Solutions

01. Ans: (c)

$$\text{Sol: } n > \frac{b}{2} + 1$$

Note: Mesh analysis simple when the nodes are more than the meshes.

02. Ans: (c)

$$\begin{aligned} \text{Sol: } \text{Loops} &= b - (n-1) \Rightarrow \text{loops} = 5 \\ n &= 7 \\ \therefore b &= 11 \end{aligned}$$

03. Ans: (a)

04.

$$\begin{aligned} \text{Sol: } \text{Nodal equations required} &= \text{f-cut sets} \\ &= (n-1) = (10-1) = 9 \\ \text{Mesh equations required} &= \text{f-loops} \\ &= b - n + 1 = 17 - 10 + 1 = 8 \\ \text{So, the number of equations required} \\ &= \text{Minimum (Nodal, mesh)} = \text{Min}(9, 8) = 8 \end{aligned}$$

05. Ans: (c)

Sol: not a tree (Because trees are not in closed path)

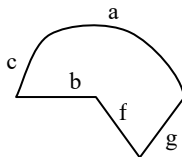

06. Ans: (a)

07.

$$\begin{aligned} \text{Sol: } \text{For a complete graph;} \\ b = n_{C_2} \Rightarrow \frac{n(n-1)}{2} = 66 \end{aligned}$$

$$n = 12$$

$$\text{f-cut sets} = (n-1) = 11$$

$$\text{f-loops} = (b - n + 1) = 55$$

$$\begin{aligned} \text{f-loop} = \text{f-cutset matrices} &= n^{(n-2)} \\ &= 12^{12-2} = 12^{10} \end{aligned}$$

08. Ans: (a)

Sol: Let $N=1$

Nodes=1, Branches = 0 ; f-loops = 0

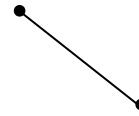
Let $N=2$ 

Nodes = 2; Branches = 1; f-loop= 0

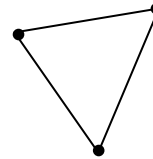
Let $N=3$ 

Nodes = 3; Branches = 3; f-loop = 1

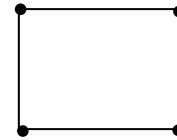
 \Rightarrow Links = 1Let $N = 4$ 

Nodes = 4; Branches = 4; f-loops=Links=1

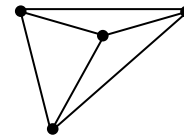
Still $N = 4$ 

Branches = 6; f-loops = Links = 3

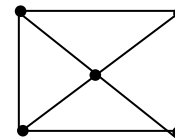
Let $N = 5$ 

Nodes = 5; Branches = 8; f-loops = Links = 4 etc

Therefore, the graph of this network can have at least “N” branches with one or more closed paths to exist.



09. Ans: (b)

Sol:

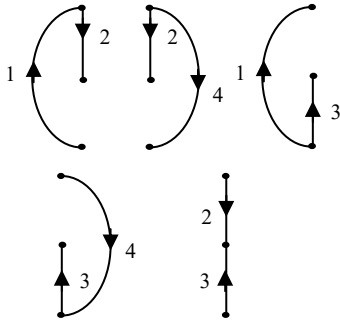

10. Ans: (d)

Sol:

(a) 1,2,3,4 →

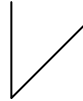

(b) 2,3,4,6 →



(c) 1,4,5,6 →



(d) 1,3,4,5 →



11. Ans: (b)

Sol: $m = b - n + 1 = 8 - 5 + 1 = 4$

12. Ans: (d)

13. Ans: (d)

Sol: The valid cut-set is

(1, 3, 4, 6)

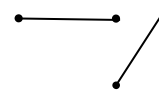

14. Ans: (b)

Sol:

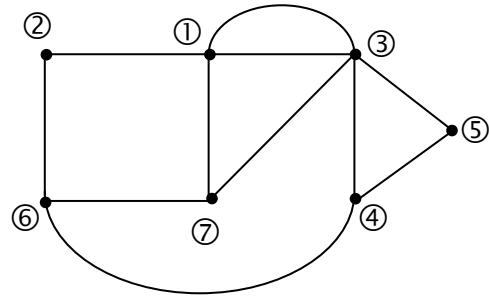

15. Ans: (d)

Sol:

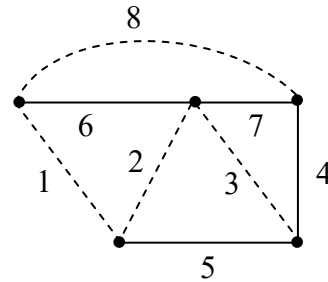

Fundamental loop should consist only one link, therefore option (d) is correct.

8

Passive Filters

Chapter

Class Room Practice Solutions

01.

Sol:

$$\left. \begin{array}{l} \omega=0 \Rightarrow V_0 = V_i \\ \omega=\infty \Rightarrow V_0 = 0 \end{array} \right\} \Rightarrow \text{Low pass filter}$$

02.

Sol: $\omega=0 \Rightarrow V_0 = \frac{V_i R_2}{R_1 + R_2}$

“V₀” is attenuated $\Rightarrow V_0 = 0$

$$\omega=\infty \Rightarrow V_0 = V_i$$

It represents a high pass filter characteristics.

03.

Sol: $H(s) = \frac{V_i(s)}{I(s)}$
 $= \frac{S^2 LC + SRC + 1}{SC}$

Put $s = j\omega$

$$= - \frac{\omega^2 LC + j\omega RC + 1}{j\omega C}$$

$$\omega=0 \Rightarrow H(s)=0$$

$$\omega=\infty \Rightarrow H(s)=0$$

It represents band pass filter characteristics

04.

Sol: $\omega = 0 \Rightarrow V_0 = 0$

$$\omega = \infty \Rightarrow V_0 = 0$$

It represents Band pass filter characteristics

05.

Sol: $\omega = 0 \Rightarrow V_0 = 0$

$$\omega = \infty \Rightarrow V_0 = V_i$$

It represents High Pass filter characteristics.

06.

Sol: $H(s) = \frac{1}{s^2 + s + 1}$

$$\omega = 0 : S = 0 \Rightarrow H(s) = 1$$

$$\omega = \infty : S = \infty \Rightarrow H(s) = 0$$

It represents a Low pass filter characteristics

07.

Sol: $H(s) = \frac{s^2}{s^2 + s + 1}$

$$\omega = 0 : S = 0 \Rightarrow H(s) = 0$$

$$\omega = \infty : S = \infty \Rightarrow H(s) = 1$$

It represents a High pass filter characteristics

08.

Sol: $\omega=0; V_0 = V_i$

$$\omega=\infty; V_0 = 0$$

It represents a low pass filter characteristics.

09.

Sol: $\omega = 0 \Rightarrow V_0 = V_{in}$

$$\omega = \infty \Rightarrow V_0 = V_{in}$$

It represents a Band stop filter or notch filter.

10.

Sol: $H(s) = \frac{S}{s^2 + s + 1}$

$$\omega = 0 : S = 0 \Rightarrow H(s) = 0$$

$$\omega = \infty : S = \infty \Rightarrow H(s) = 0$$

It represents a Band pass filter characteristics

11.

Sol: $H(s) = \frac{S^2 + 1}{s^2 + s + 1}$

$$\omega = 0 \Rightarrow S = 0 \Rightarrow H(s) = 1$$

$$\omega = \infty \Rightarrow S = \infty \Rightarrow H(s) = 1$$

It represents a Band stop filter



12.

Sol: $H(s) = \frac{1-s}{1+s}$

$\omega = 0 \Rightarrow S = 0 \Rightarrow H(s) = 1$

$\omega = \infty \Rightarrow S = \infty \Rightarrow H(s) = -1 = 1 \angle 180^\circ$

It represents an All pass filter

13. Ans: (c)

Sol.

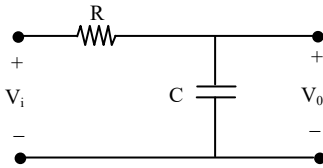

$\omega = 0 \Rightarrow V_0 = V_i$

$\omega = \infty \Rightarrow V_0 = 0$

$$V_0(s) = \left(\frac{V_i(s)}{R + \frac{1}{sc}} \right) \left(\frac{1}{sc} \right)$$

$$\frac{V_0(s)}{V_i(s)} = H(s) = \frac{1}{SscR + 1}$$

$$H(j\omega) = \frac{1}{1 + j\omega c R} = \frac{1}{1 + j \frac{f}{f_L}}$$

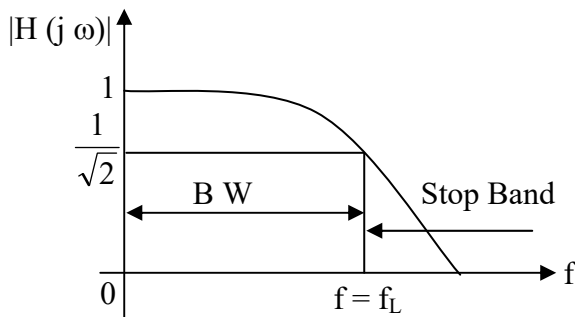

Where $f_L = \frac{1}{2\pi RC}$

$$|H(j\omega)| = \frac{1}{\sqrt{1 + \left(\frac{f}{f_L}\right)^2}}$$

$$\angle H(j\omega) = -\tan^{-1}\left(\frac{f}{f_L}\right)$$

$f = 0 \Rightarrow \phi = 0^\circ = \phi_{\min}$

$f = f_L \Rightarrow \phi = -45^\circ = \phi_{\max}$

14. Ans: (b)

15. Ans: (d)

16. Ans: (a)

17. Ans: (c)