

ELECTRONICS & TELECOMMUNICATION ENGINEERING

Paper II

Time Allowed : Three Hours

Maximum Marks : 300

QUESTION PAPER SPECIFIC INSTRUCTIONS

Please read each of the following instructions carefully before attempting questions.

There are **EIGHT** questions divided in **TWO** Sections.

Candidate has to attempt **FIVE** questions in all.

Question Nos. 1 and 5 are compulsory and out of the remaining, **THREE** are to be attempted choosing at least **ONE** question from each Section.

The number of marks carried by a question/part is indicated against it.

Answers must be written in the medium authorized in the Admission Certificate which must be stated clearly on the cover of this Question-cum-Answer (QCA) Booklet in the space provided. No marks will be given for answers written in a medium other than the authorized one.

Assume suitable data, if considered necessary and indicate the same clearly.

Unless otherwise mentioned, symbols and notations carry their usual standard meanings.

Attempts of questions shall be counted in sequential order. Unless struck off, attempt of a question shall be counted even if attempted partly. Any page or portion of the page left blank in the Question-cum-Answer Booklet must be clearly struck off.

SECTION 'A'

1.(a)

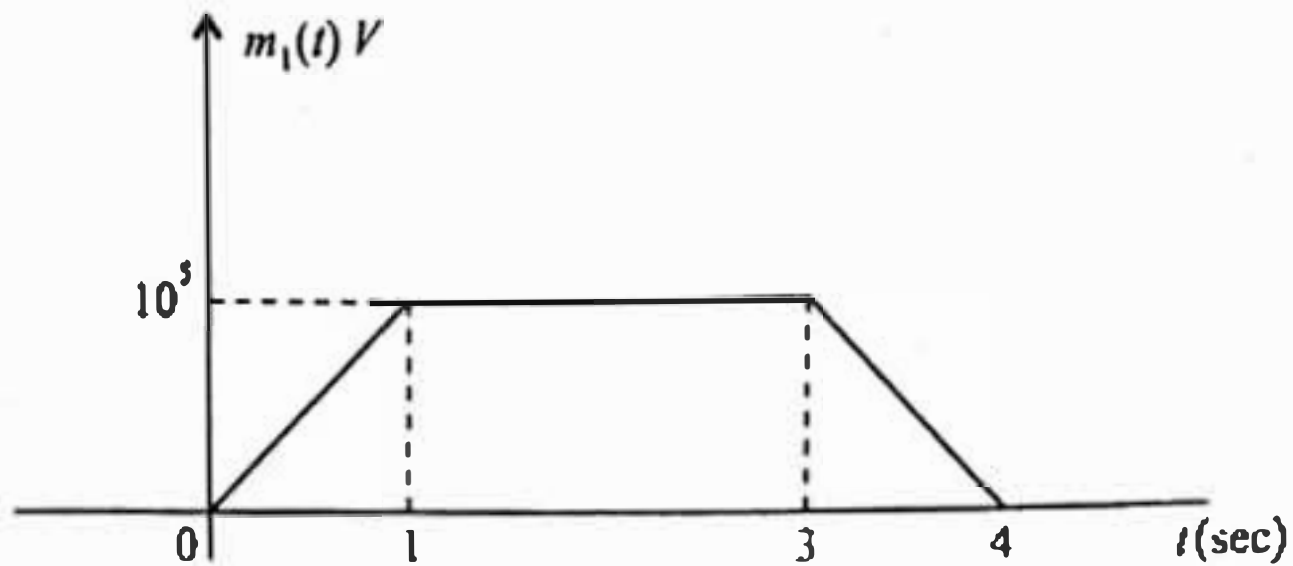

Consider a message signal $m_1(t)$ as shown and message signal $m_2(t) = \sin c(2 \times 10^4 t)$, in volts.

- (i) If $m_1(t)$ is frequency modulated on a carrier with frequency 10^6 Hz with a frequency deviation constant (k_f) equal to 5 Hz/V, what is the maximum instantaneous frequency of the modulated signal?
- (ii) If $m_1(t)$ is phase modulated with phase deviation constant (k_p) equal to 3 rad/V, what is the maximum instantaneous frequency of the modulated signal? What is the minimum instantaneous frequency of the modulated signal?
- (iii) If $m_2(t)$ is frequency modulated with $k_f = 10^3$ Hz/V, what is the maximum instantaneous frequency of the modulated signal? What is the bandwidth of the modulated signal? 10

1.(b)

Consider the following second-order transfer function :

$$G_p(s) = \frac{K}{(\tau_1 s + 1)(\tau_2 s + 1)}$$

For a unit impulse input, find the output response as a function of time. What is the value of peak overshoot (M_p) and when does it occur? 10

1.(c)

What is the role of cache memory in computer? With the help of suitable schematic, explain how L2 cache is added to a microprocessor with an on-chip L1 cache. 10

1.(d)

Determine the null to null beamwidth of a 20 element antenna array where the interelement spacing is 0.5λ operated as end fire array. If the same array is to be operated for the same null to null beamwidth in broadside operation, find the number of elements required for the array. 10

1.(e)

System is characterized by $y[n] = a \cdot y[n] + x[n] + b \cdot x[n-1]$ where a, b are constants.

- (i) Draw Signal flow graph for the system.
- (ii) Plot impulse response of the system.
- (iii) State restrictions on the system constants so that system is LTI. 10

1.(f)

For a microwave link, define all the components contributing to system gain. Determine system gain for a microwave link operating at 1.8 GHz carrier frequency. Each station has a 2.4 m diameter parabolic antenna fed by 100 m of airfilled coaxial cable. The distance between stations is 40 km. A reliability objective of 99.99% is desired. The terrain is smooth and climate is humid.

Assume feeder loss = 10.8 dB, branching loss = 4 dB and gain of each antenna = 31.2 dB. 10

2.(a) Consider the experiment of tossing a fair coin. The random process $X(t)$ is defined as follows : $X(t) = \sin(\pi t)$, if head shows up and $X(t) = 4t$, if the toss results in a tail. Sketch the sample functions. Find the expression for the PDF of the random variables obtained from sampling the process at (i) $t = 0$, (ii) $t = 2$. 15

2.(b) (i)

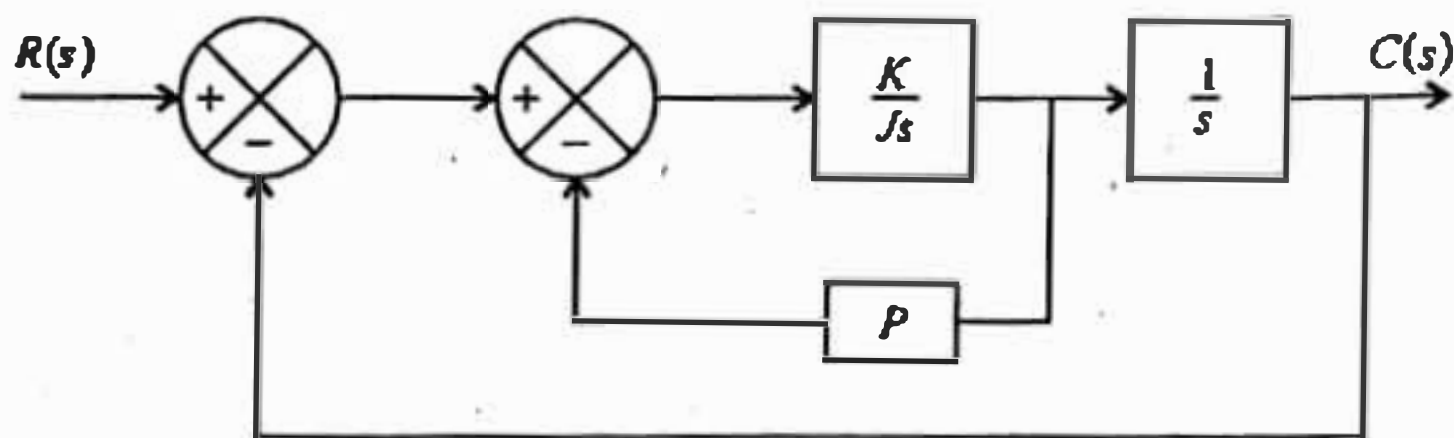

Determine the value of K & P of the closed loop system shown in the figure, so that the maximum overshoot in unit step response is 25% and the peak time is 2 sec. Assume that $J = 1 \text{ kg-m}^2$. 10

(ii) Show that the root loci for a control system with

$$G(s) = \frac{K(s^2 + 6s + 10)}{s^2 + 2s + 10}, H(s) = 1$$

are arcs of the circle centred at the origin with radius equal to $\sqrt{10}$. 10

2.(c) Five soldiers, A, B, C, D, E , volunteer to perform an important military task if their following conditions are satisfied :

- (i) Either A or B or both must go.
- (ii) Either C or E , but not both, must go.
- (iii) Either both A and C go or neither goes.
- (iv) If D goes, then E must also go.
- (v) If B goes, then A and D must also go.

Define the variables A, B, C, D, E such that an unprimed variable will mean that the corresponding soldier has been selected to go. Determine the expression which specifies the combinations of the volunteers who can get the assignment. 25

3.(a) (i) Let the AM signal at the input to envelope detector, has the modulation index of 0.5 with the carrier amplitude of 2 V. Message signal, $m(t)$, is a tone signal of frequency 5 kHz and the carrier frequency $f_c \gg 5$ kHz. If the (two-sided) noise PSD at the detector input is 10^{-8} watts/Hz. What is the expected $(SNR)_o$ of this scheme? By how many dB, this scheme is inferior to DSB-SC? 10

(ii) Determine the Nyquist sampling rate and the Nyquist sampling interval for the signals:

(A) $\sin c(100 t) + \sin c(50 t)$

(B) $\sin c(100 t) + 3 \sin c^2(60 t)$

(C) $\sin c(50 t) \sin c(100 t)$ 10

3.(b) (i) A circular disk of radius 2.54 cm with a charge density $8 \sin \frac{\phi}{2}$ mC/m² is enclosed in a surface S . Determine the net flux crossing S . Now, if the disk is divided into four equal quadrants and one quadrant is placed inside the same surface what will be the net flux crossing S ? 10

(ii) The potential function between two concentric cylinders varies in a natural logarithmic manner. If the \vec{E} field between two cylinders is to vary as $\frac{50}{r} a_r$ V/m in a concentric cylindrical system of radii $r_{inner} = 2$ mm and $r_{outer} = 25$ mm find the potential difference needed. 10

3.(c) The downlink C/N_0 ratio in a direct broadcast satellite (DBS) system is estimated to be 85 dB-Hz. The specifications of the links are:

Satellite EIRP = 57 dBW

Downlink carrier frequency = 12.5 GHz

Data rate = 10 Mbps

Required E_b/N_0 at the receiving earth terminal = 10 dB

Distance of the satellite from the receiving earth terminal = 41,000 km.

Calculate the minimum diameter of the dish antenna needed to provide a satisfactory TV reception, assuming that the dish has an efficiency of 55 per cent and it is located alongside the home where the temperature is 310 K. For this calculation, assume that the operation of the DBS system is essentially downlink limited. 20

4.(a) (i) Show the value of all bits of a 12-bit register that holds the number equivalent to decimal 215 in

(A) binary

(B) binary coded octal

(C) binary coded hexadecimal and

(D) binary coded decimal. 10

- 4.(b) (ii) There is an asynchronous communication interface between a CPU and a printer. Draw a flowchart that describes the sequence of operations in the interface when CPU sends characters to be printed. 10

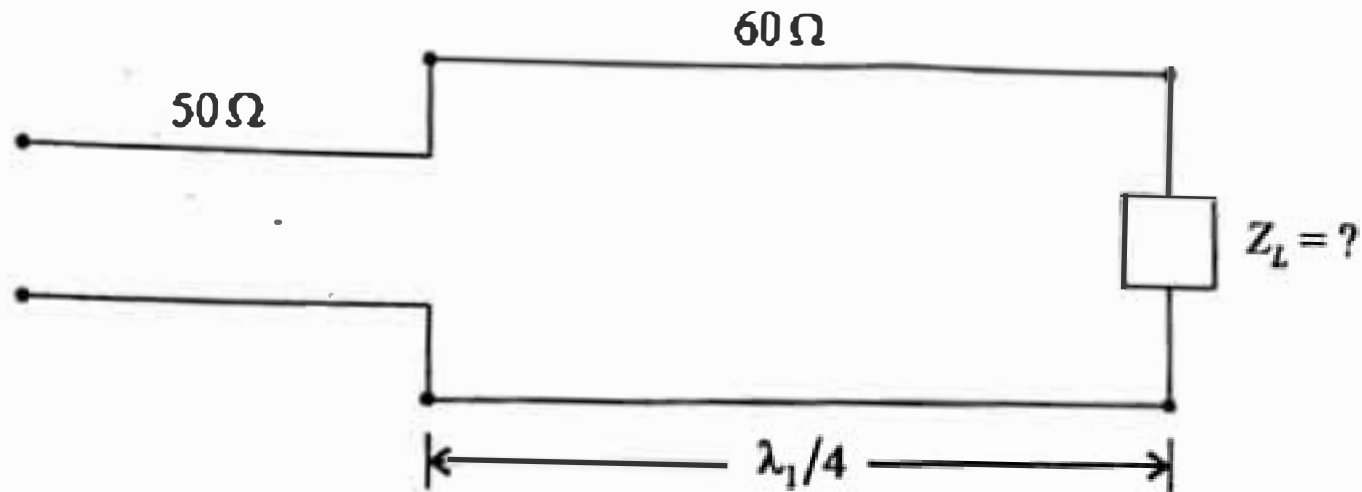

Find the load impedance which can be matched to a 50 Ω transmission line with a quarter wave line (at $f = f_1$) of characteristic impedance 60 Ω. If the frequency is doubled (at $f = 2f_1$), what will be the VSWR on 50 Ω line? 20

- 4.(c) (i) Explain stuck-at-fault model for digital circuits with its salient features.
(ii) Two faults are said to be indistinguishable if they cause the circuit to malfunction in exactly the same way. For the circuit given, comment if c wire stuck-at-0 and f wire stuck-at-1 results in indistinguishable fault. 20

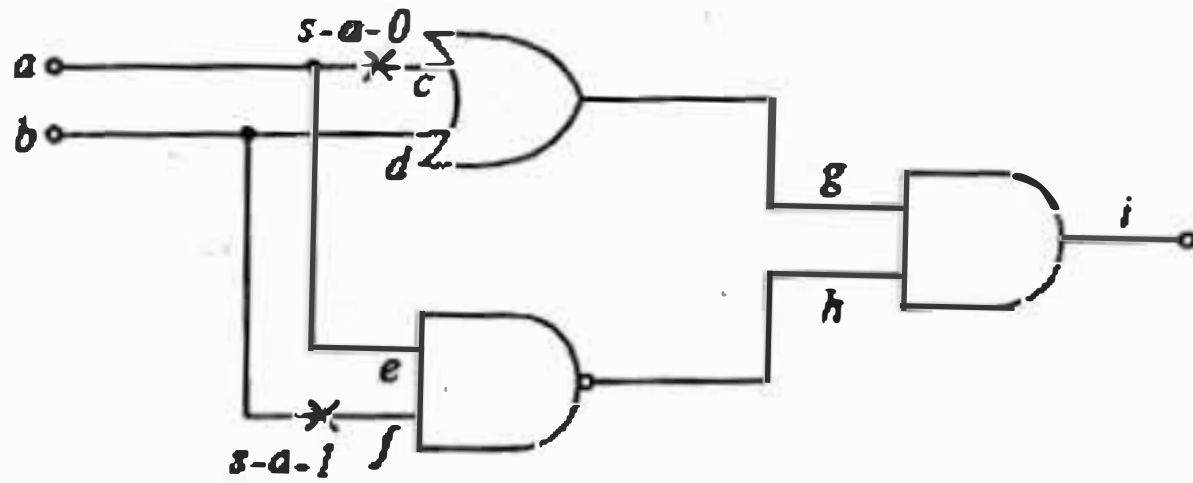

SECTION 'B'

5.(a) Binary antipodal signals are used to transmit information over an AWGN channel. The prior probabilities for the two input symbols are $\frac{1}{3}$ and $\frac{2}{3}$.

- (i) Determine the optimum maximum likelihood decision rule for the detector.
(ii) Determine the average probability of error as a function of E_b/N_0 . 10

5.(b) Derive the expression in time domain for the unit step response of second order system. 10

5.(c) A CPU with a 20 MHz clock is connected to a memory unit having access time of 40 nS. Formulate a read and write diagram showing respective strobe. 10

5.(d) An air dielectric rectangular waveguide has dimensions of 16.52×8.26 cm². When it is short circuited at one end and fed with power at the other end, it is found to have 20 cm distance between two successive minima on the waveguide. Find the cut off frequency of the waveguide, operating frequency of the signal and wave number assuming TE_{10} mode of operation. 10

5.(e) Design binary serial adder using DFF performing following operation on reset pulse of one clock pulse duration at $t = 0$.

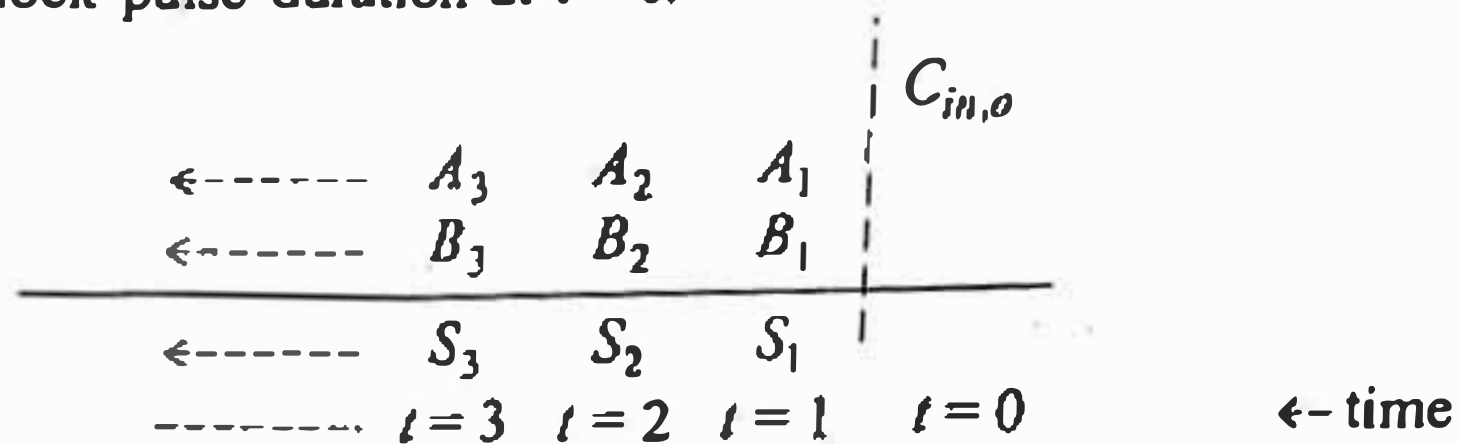

Provision should be made to assert $C_{in,0}$ as 1 or 0 during the reset pulse. 10

5.(f) Define different types of losses encountered while setting up a fibre-optic link. Determine optical power received in optical fibre link with following specifications :

- Link length = 20 km
- LED output power = 30 mW
- Optical cable loss = 0.5 dB/km
- Source to fibre interface loss = 2.9 dB
- Fibre to detector loss = 2.1 dB 10

- 6.(a) (i) With proper schematic, show the launch and propagation of light in optical fibre. Discuss the relationship between critical angle and numerical aperture. 10
- (ii) The active region of a $1.3 \mu\text{m}$ Fabri-Perot InGaAsP laser is $L = 250 \mu\text{m}$, internal loss coefficient $\alpha_{int} = 30 \text{ cm}^{-1}$, mode refractive index $n = 3.3$, the confinement factor $\Gamma_a = 0.4$. Neglect the material dispersion. Find the material gain, g_m , required for the laser to reach threshold. Find the distance $\Delta\nu_L$ between FP cavity modes. 10

6.(b) Draw a detailed flow-chart for a program to check for a CR code (hexadecimal OD) in a memory buffer. The buffer contains two characters per word. When the code for CR is encountered, the program transfers it to bits 0 through 7 of location LNE without disturbing bits 8 through 15. Justify the action taken in each block of flow-chart taking an appropriate example. 20

- 6.(c) An ISP is granted a block of addresses starting with 190.100.0.0/16 (65,536 addresses). The ISP needs to distribute these addresses to three groups of customers as follows :
- (i) The first group has 64 customers; each needs 256 addresses.
 - (ii) The second group has 128 customers; each needs 128 addresses.
 - (iii) The third group has 128 customers; each needs 64 addresses.

Design the subblocks and find out how many addresses are still available after these allocations. 20

- 7.(a) (i) Consider a discrete memoryless source whose alphabet consists of K equiprobable symbols.
- (A) Explain why the use of a fixed-length code for the representation of such a source is about as efficient as any code can be.
- (B) What conditions have to be satisfied by K and the codeword length for the coding efficiency to be 100 per cent? 10
- (ii) A DPCM system uses a linear predictor with a single tap. The normalized autocorrelation function of the input signal for a lag of one sampling interval is 0.75. The predictor is designed to minimize the prediction error variance. Determine the processing gain attained by the use of this predictor. 10

7.(b) An open loop system has transfer function

$$G(s)H(s) = \frac{100}{(s+1)(0.1s+1)}$$

Discuss the stability of the closed loop system by Nyquist stability criterion. 20

- 7.(c) (i) Consider a demand paging system with following time measured utilizations :
- CPU utilization = 20%
 - Paging disk = 97.7%
 - Other I/O devices = 05%

For each of the following, say whether it will (or is likely to) improve CPU utilization. Explain your answer.

- Install a faster CPU
- Install a bigger paging disk
- Increase the degree of multi-programming
- Install a faster hard disk, or multiple controllers with multiple hard disks.

10

- (ii) A computer has 2 GB of RAM of which the operating system occupies 256 MB. The processes are all 128 MB and have the same characteristics. If the goal is 99% CPU utilization, what is the maximum I/O wait that can be tolerated? 10

- 8(a) (i) If the energy stored in a system of two equal point charges separated by a distance of 0.3 m is to be 400 nJ, find the charge required. The medium is free space. 10

- (ii) The conductivities of diamagnetic materials copper and silver are given below :

$$\sigma_{\text{Silver}} = 6.17 \times 10^7 \text{ S/m}$$

$$\sigma_{\text{Cu}} = 3.72 \times 10^7 \text{ S/m}$$

Find the skin depths for both these materials at 10 kHz. Determine the frequency at which copper material will have the same skin depth as that of silver material at $f = 10$ kHz. 10

8.(b)

(i) Ideal frequency selective filters (LP, HP, BP, BS) are unrealizable in natural systems — Prove with comments. 10

(ii) For function $f(x_1, x_2, x_3, x_4)$ given by

$f(x_1, x_2, x_3, x_4) = \Sigma 3, 4, 8, 9, 10, 12, 15$ and don't care terms

$f(x_1, x_2, x_3, x_4) = \Sigma_d 2, 5, 11.$

(A) Minimize the function using K-map.

(B) Realize the above function on sum of product. (AND-OR) programmable logic array. 10

8.(c)

(i) Define the functionality of each layer in OSI model. Differentiate switch (used in LAN) from router (used in WAN) on the basis of layers present and their functions. 10

(ii) Give layered architecture of TCP/IP protocol and define type of addresses used at each layer. 10