

# ELECTRICAL ENGINEERING

## PAPER—II

Time Allowed : Three Hours

Maximum Marks : 300

### QUESTION PAPER SPECIFIC INSTRUCTIONS

**Please read each of the following instructions carefully  
before attempting questions**

There are EIGHT questions divided in two Sections.

Candidate has to attempt FIVE questions in all.

Question Nos. 1 and 5 are compulsory and out of the remaining, THREE are to be attempted choosing at least ONE question from each Section.

The number of marks carried by a question/part is indicated against it.

Assume suitable data, if considered necessary and indicate the same clearly.

Unless otherwise mentioned, symbols and notations carry their usual standard meanings.

Attempts of questions shall be counted in sequential order. Unless struck off, attempt of a question shall be counted even if attempted partly.

Any page or portion of the page left blank in the QCA Booklet must be clearly struck off.

Answers must be written in ENGLISH only.

## SECTION—A

1. (a) A single-phase AC voltage controller is feeding a resistive load of  $26.45 \Omega$  from an AC source of 230 V, 50 Hz. Compute the firing angle to deliver 1000 W to the load. Also compute the p.f. at which this power is delivered. Draw a neat circuit diagram and waveforms of voltage at load terminals with current flowing in the load. 12

(b) An open-loop system  $G(s) = \frac{1}{s^2(\tau s + 1)}$  is placed in cascade with a proportional and derivative controller  $K(s) = (1 + T_d s)$ . If their unity feedback closed-loop system oscillates at a frequency of  $\sqrt{2}$  rad/second, find the ranges/values of the system and controller parameters, i.e., ranges/values of  $K$ ,  $T_d$  and  $\tau$ . 12

(c) Determine the mechanical time constant of rotor of an electrical machine in terms of its moment of inertia  $J$  kg-m<sup>2</sup> and windage cum friction coefficient  $f$  N-m/rad/s. Also explain the method to determine mechanical time constant experimentally in laboratory. 12

(d) An electric train running between two stations A and B, 10 km apart and maintained at voltages 550 V and 500 V respectively, draws a constant current of 600 A. The resistance for both go and return conductors is  $0.04 \Omega/\text{km}$ . Find the point of minimum potential between the stations, the voltage at that point and currents drawn from both the stations at that point. 12

(e) The continuous-time Fourier transform (CTFT) of a square pulse defined by  $x(t) = 1$  for  $-0.5 \leq t \leq 0.5$  is given by

$$X(\omega) = \frac{\sin\left(\frac{\omega}{2}\right)}{\frac{\omega}{2}}$$

Use the properties of CTFT and synthesize the equation, and find the CTFT of the following signals  $y(t)$  and  $z(t)$  : 12

$$y(t) = \begin{cases} 2, & \text{for } 0 \leq t < 1 \\ -2, & \text{for } 1 \leq t \leq 2 \\ 0, & \text{elsewhere} \end{cases}$$

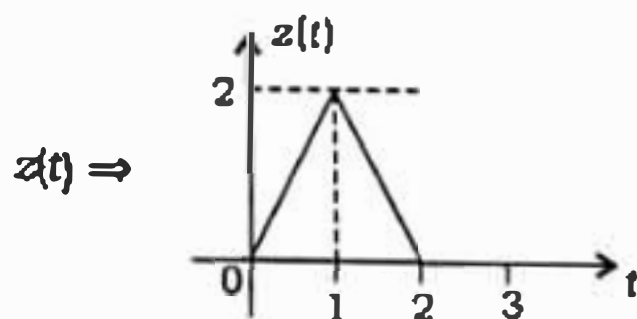

2. (a) A single-phase full bridge inverter is used to produce a 50 Hz voltage across a series  $R_L$  load ( $R = 10 \Omega$  and  $L = 20 \text{ mH}$ ) using bipolar PWM. The DC input to the bridge is 380 V, the amplitude modulation ratio  $m_a = 0.8$  and frequency modulation ratio  $m_f = 21$ . Consider dominant harmonics to be frequency dominant and its nearby side frequencies (both sides). Assume normalized Fourier coefficient for  $m_a = 0.8$  to be 82% for dominant harmonic frequency and 22% for the nearby side frequencies.

Determine—

- (i) amplitude of 50 Hz component of output voltage and current;
- (ii) power absorbed by the load resistor;
- (iii) THD of the load current.

Also compare the amplitude of 50 Hz component of output voltage with square wave and quasisquare wave output.

20

- (b) A 3-phase, 6-pole, 460 V, 50 Hz induction generator operates at 480 V. The generator has its rated output power of 20 kW. It is driven by a turbine at a speed of 1015 r.p.m. The generator has the following electrical parameters :

$$\begin{aligned} R_1 &= 0.2 \Omega & R_2 &= 0.15 \Omega & R_{sh} &= 320 \Omega \\ X_1 &= 1.2 \Omega & X_2 &= 1.29 \Omega & X_M &= 42 \Omega \end{aligned}$$

Find the active power delivered by the generator and reactive power it requires from the system to operate.

20

- (c) (i) Under what condition a single line-to-ground fault at the terminals of a generator can be more severe than a 3-phase symmetrical fault at the same location?
- (ii) A 3-phase power system is represented by one-line diagram as shown in the figure below :

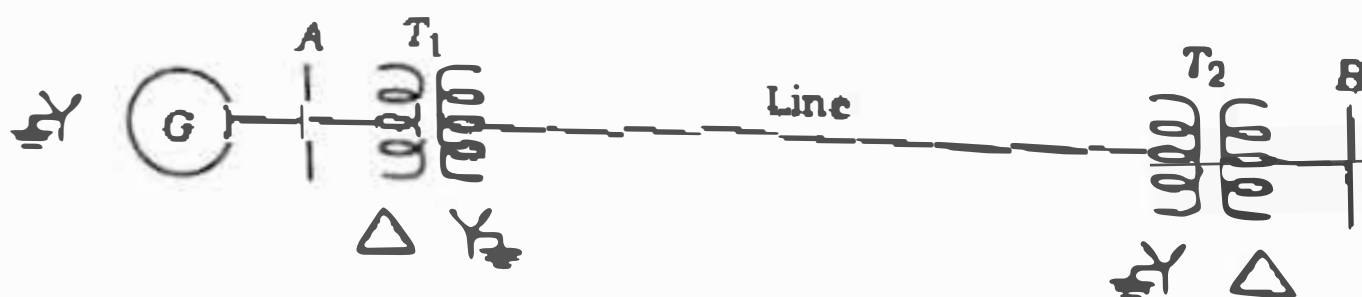

The ratings of the equipments are the following :

Generator G : 15 MVA, 6.6 kV,  $X_1 = 15\%$ ,  $X_2 = 10\%$

Transformers : 15 MVA, 6.6 kV delta/33 kV star,  $X_1 = X_2 = X_0 = 6\%$

Line reactance :  $X_1 = X_2 = 2 \Omega$  and  $X_0 = 6 \Omega$

Find the fault current for a ground fault on one of the bus bars at B.

20

3. (a) For the circuit shown below, calculate the output voltage :

$$R_1 = 1 \text{ k}\Omega \quad R_2 = 2 \text{ k}\Omega \quad R_3 = 3 \text{ k}\Omega$$

$$R_4 = 10 \text{ k}\Omega \quad R_5 = 10 \text{ k}\Omega \quad R_6 = 100 \text{ k}\Omega$$

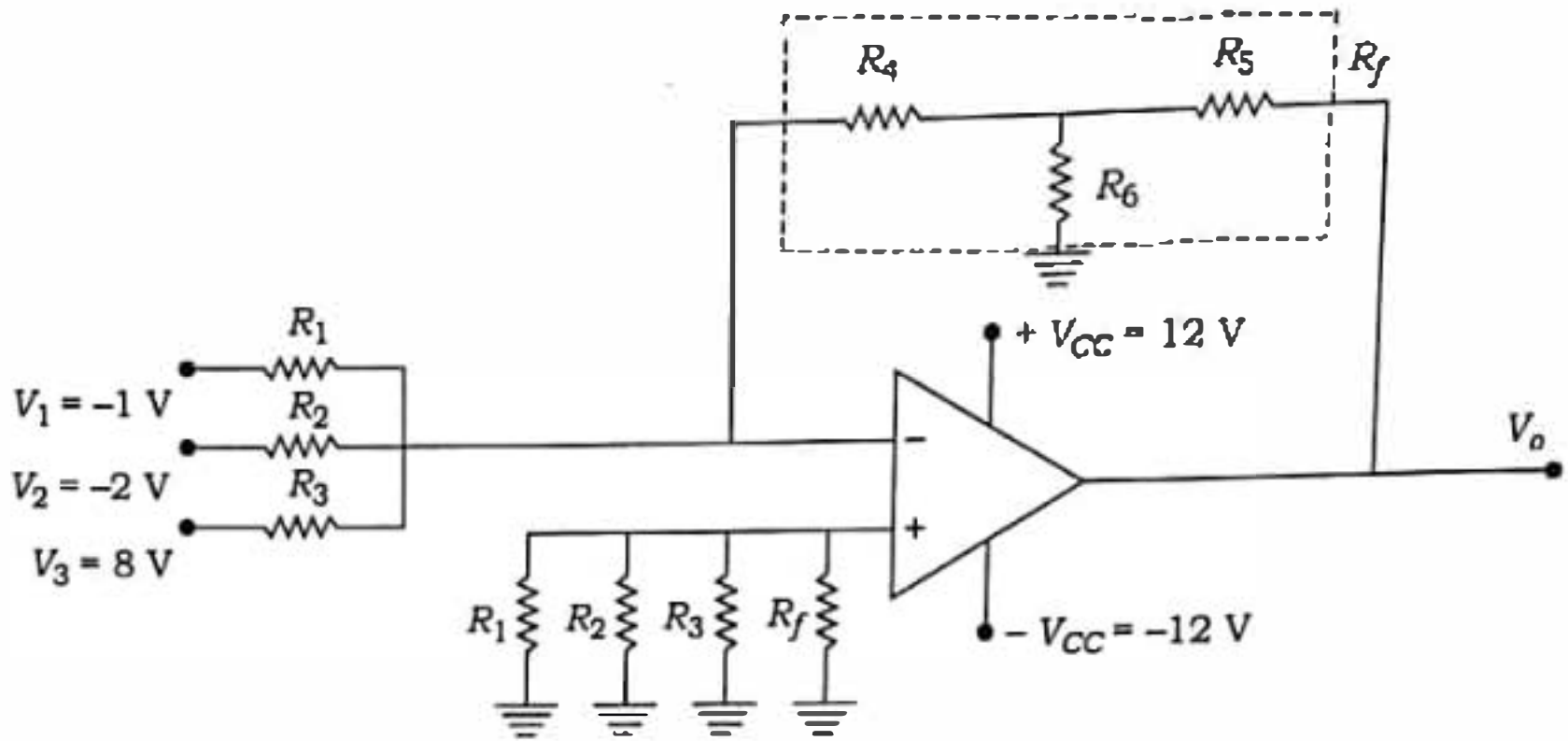

$$V_1 = -1 \text{ V} \quad V_2 = -2 \text{ V} \quad V_3 = 8 \text{ V}$$

(b) A signal  $x_a(t)$  is band-limited to the range  $900 \text{ Hz} \leq f \leq 1100 \text{ Hz}$  (assume the shape of an isosceles triangle for continuous Fourier transform and  $|X_a(f)| = 1$  and  $f = 1000 \text{ Hz}$ ). It is used as an input to the system shown below :

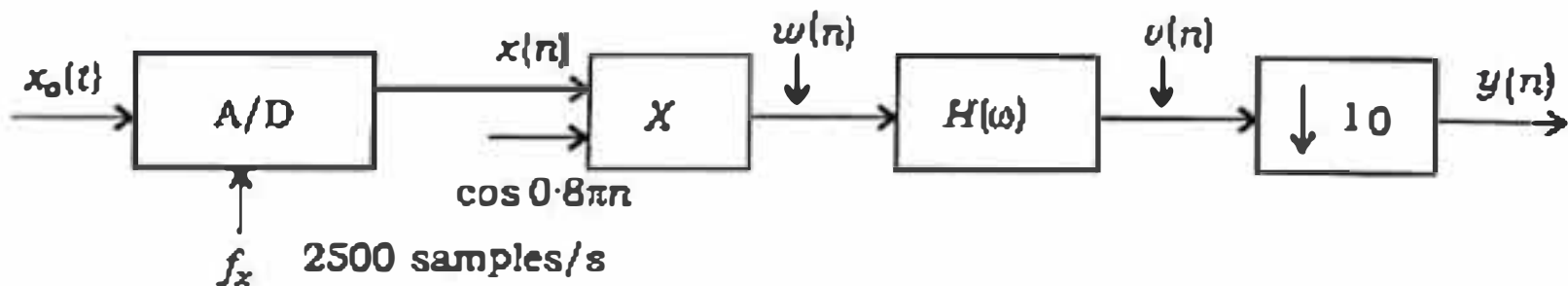

In this system,  $H(\omega)$  is a low-pass filter with a discrete cut-off frequency equivalent to  $f_c = 125 \text{ Hz}$  (normalized w.r.t. the sample rate at the point in the block diagram). Determine and sketch the spectra of  $X(\omega_x)$ ,  $W(\omega_w)$ ,  $V(\omega_v)$  and  $Y(\omega_y)$  w.r.t.  $\omega_x$ ,  $\omega_w$ ,  $\omega_v$  and  $\omega_y$  respectively for  $-\pi < \omega < \pi$ .

20

(c) For the system shown in the figure below, the step response of  $G(s)$  is given by  $(1.5 - 2e^{-t} + 0.5e^{-2t})u(t)$  and  $K(s)$  is the integral controller with  $K(s) = \frac{K}{s}$ . Sketch the approximate root locus of the closed-loop system poles as  $K$  varies from 0 to  $\infty$ . Also calculate the real part of poles when  $K$  becomes  $\infty$  :

20

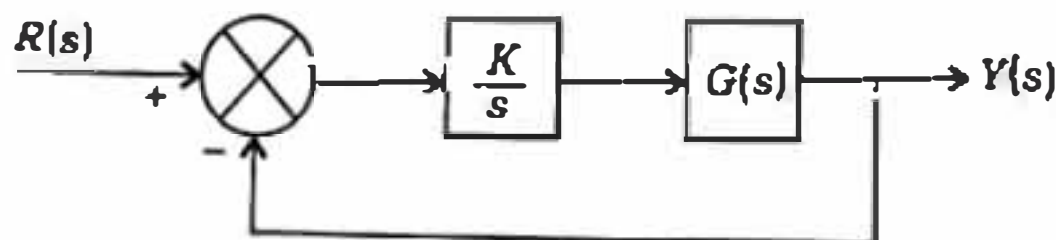

4. (a) (i) What do you mean by grading of cables? What are the methods of grading?  
(ii) Derive the condition for minimum value of gradient at the surface of the conductor.  
(iii) Determine the economic overall diameter of a single-core cable metal sheathed for a working voltage of 75 kV, if the dielectric strength of the insulating material is 60 kV/cm. 20

- (b) A 400 V, 50 Hz, 6-pole, 960 r.p.m.,  $\gamma$ -connected induction motor has the following parameters per phase referred to stator :

$$r_1 = 0.4 \Omega; \quad r_2' = 0.2 \Omega; \quad x_1 = x_2' = 1.5 \Omega; \quad X_m = 30 \Omega$$

The motor is controlled by a variable frequency inverter at a constant flux of rated value for operation below synchronous speed, while in super-synchronous operation region flux is weakened by keeping voltage constant at rated value. Assume straight line for torque vs. slip characteristics for slip  $s < s_m$  (motor region) and  $s > s_m'$  (generator region). The connected load on the shaft is constant torque type.

Calculate the inverter frequency and current drawn by the stator when torque on the shaft is half-rated while motoring at 500 r.p.m. 20

- (c) Why is the waveshape of magnetizing current of a transformer non-linear? Explain the phenomenon of in-rush magnetizing current and derive its expression in terms of  $\alpha$ , the angle of the voltage sinusoid at  $t = 0$  and  $\Phi_r$ , the residual core flux at  $t = 0$ .

Use the graph sheet to show non-linearity of current from the assumed  $\Phi$ - $i$  diagram of magnetic core of the transformer. 20

#### SECTION—B

5. (a) A DC motor has an armature resistance of  $0.5 \Omega$  and  $K\phi$  of 3 Vs. The motor is driven by a single-phase thyristorized full converter. The input to the converter is an AC source of 230 V, 50 Hz. The motor is used as a prime mover of a forklift. In the upward direction, the mechanical load is 69 Nm and the triggering angle is  $\alpha = 15^\circ$ . In the downward direction, the load torque is 180 Nm. Calculate the triggering angle required to keep the downward speed equal in magnitude to upward speed. Assume continuous motor current for all operation. Also calculate the triggering angle to keep the motor at holding position while it was moving upward. 12

- (b) The primary side of an ideal transformer (having 400 turns in primary winding and 720 turns in secondary winding) is excited by a 1000 V, 50 Hz AC source. The secondary of the transformer is connected to a resistive load of 80 kW. There is one tapping in secondary winding at 480 turns and this tapping is supplying a pure inductive load of 100 kVA. Determine the primary current and its power factor. 12

(c) (i) Obtain an expression for the total average power of a sinusoidal AM wave

$$v_c = V_c \sin \omega_c t$$

$$v_m = V_m \sin \omega_m t$$

(ii) An AM transmitter broadcasts a carrier power of 100 kW. Determine the radiated power at the amplitude modulation index of 0.8. 12

(d) Given a unity feedback system with  $G(s) = \frac{K}{s(s+a)}$  as shown in the figure :

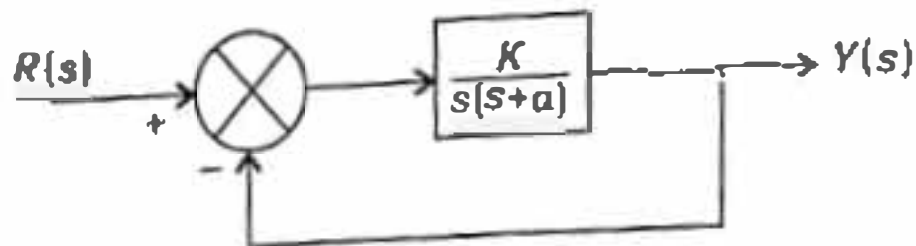

(i) Find the values of  $K$  and  $a$ , when the closed-loop system has  $K_v = 100$  and admits 20% peak overshoot.

(ii) Find the values of  $K$  and  $a$ , when the closed-loop system has settling time (2% tolerance band) of 2 seconds and admits 10% peak overshoot. 12

(e) Two relays  $R_1$  and  $R_2$  are connected in two sections of a feeder as shown in the following figure. CTs are of ratio 1000/5. The plug setting of relay  $R_1$  is 100% and of  $R_2$  is 125%. The operating time characteristics of the relay is given in the following table :

Operating time characteristics for TMS = 1						
PSM	2	4	5	8	10	20
Operating time (seconds)	10	5	4	3	2.8	2.4

The time multiplier setting of the relay  $R_1$  is 0.3. The time grading scheme has a discriminative margin of 0.5 s between the relays. A three-phase short circuit at  $F$  results in a fault current of 5000 A. Find the actual operating time of  $R_1$  and  $R_2$ . What is the time multiplier setting (TMS) of  $R_2$ ? 12

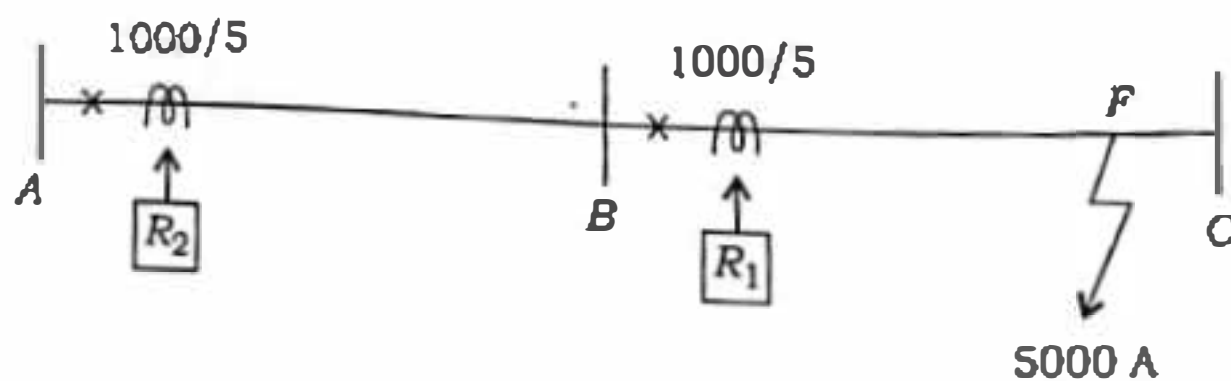

6. (a) A 20 kW, 500 V DC shunt motor (having 90% full-load efficiency) has 40% armature copper losses of its full-load losses. Calculate the resistance values of a 4-section starter suitable for limiting starting current between 120% to 200% of full-load current. Assume field resistance of 250  $\Omega$ . 20

- (b) (i) Differentiate between characteristic impedance and surge impedance of a line. What do you mean by surge impedance loading (SIL) of a transmission line?
- (ii) A three-phase, 50 Hz transmission line is 400 km long. The voltage at the sending end is 220 kV. The line parameters are  $r = 0.125$  ohm/km,  $x = 0.4$  ohm/km and  $y = 2.8 \times 10^{-6}$  mho/km. Find the sending-end current and receiving-end voltage when there is no load on the line. Make a comment on the value of receiving-end voltage. 20

- (c) A boost converter is required to have an output voltage of 48 V and supply a load current of 5 A. The input varies from 12 V–24 V. A control circuit adjusts the duty ratio to keep the output voltage constant. Select the switching frequency to be 200 kHz. Determine a value of inductor such that the variation in inductor current is no more than 40% of average inductor current for all operation. Prescribe a suitable value of capacitor such that output ripple is no more than 2%. 20

7. (a) A full-controlled full-wave bridge AC/DC converter is fed from a single-phase, 230 V, 50 Hz supply, and is in turn feeding to an  $R$ - $L$  load ( $R = 10 \Omega$  and  $L = 100$  mH). The firing angle  $\alpha = 60^\circ$ . Investigate whether load current remains continuous or not. Compute r.m.s. load current considering only the dominant harmonic, and determine the power absorbed by the load. Also compute voltage ripple factor. 20

- (b) For the electromechanical system shown below, the air-gap flux density under steady-state operating condition is given by

$$B(t) = B_m \sin \omega t$$

Find the instantaneous coil voltage and current along with force of magnetic field origin : 20

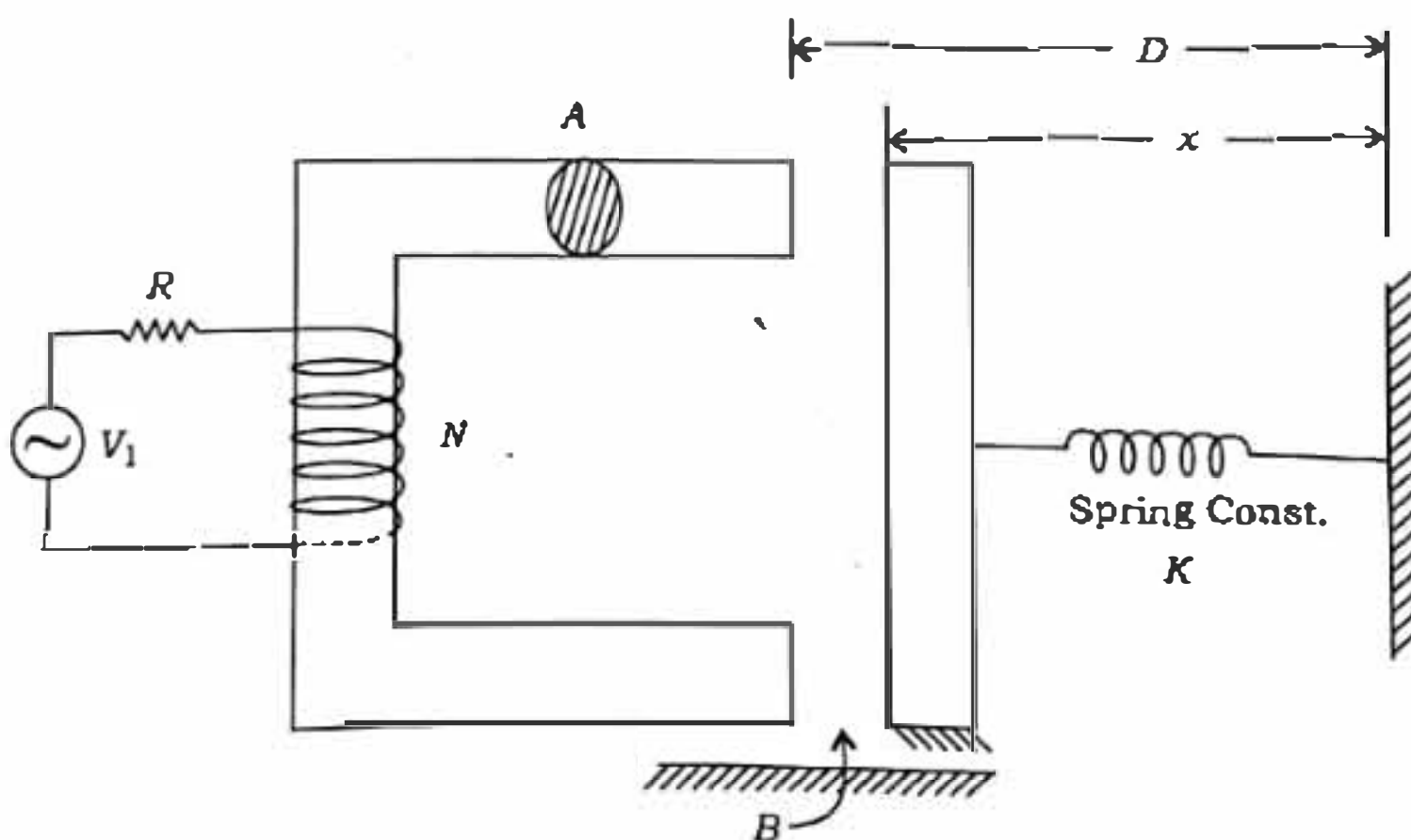

- (c) (i) In case of a circuit breaker, define the terms 'restriking voltage' and 'RRRV', and express their maximum values in terms of system voltage.
- (ii) Which circuit breaker is preferred for voltages 132 kV and above?
- (iii) In a 132 kV system, the reactance per phase up to the location of circuit breaker is  $5 \Omega$  and capacitance to earth is  $0.03 \mu\text{F}$ . Calculate the maximum value of restriking voltage, the maximum value of RRRV and frequency of transient oscillation.

20

8. (a) A signal is given by

$$x(t) = \cos(28\pi t) + 2\cos(40\pi t) + 3\cos(70\pi t)$$

This signal is sampled at 90 samples/s to get discrete-time signal  $x(n)$ .

- (i) Find the periodicity of the individual components in the signal and hence find the periodicity  $N_0$  of the signal  $x(n)$ .
- (ii) Find the harmonic indices  $m$  ( $0 \leq m < N_0$ ) of the complex DTFS coefficient  $D_m$ , where  $D_m$  is non-zero.
- (iii) By inspection, write the magnitude of the coefficients  $|D_m|$  for the indices found above.

20

- (b) For a unity feedback time delay system with open-loop transfer function

$$G(s) = \frac{Ke^{-Ts}}{s(s+2)}$$

calculate—

- (i) the maximum tolerable value of delay  $T$ , when  $K=1$ ;
- (ii) phase margin when  $K=\sqrt{5}$  and delay  $T=0.5$  second.

20

- (c) Given a system in state space representation as

$$\begin{bmatrix} \dot{x}_1 \\ \dot{x}_2 \end{bmatrix} = \begin{bmatrix} 0 & 1 \\ 0 & -3 \end{bmatrix} \begin{bmatrix} x_1 \\ x_2 \end{bmatrix} + \begin{bmatrix} 0 \\ 1 \end{bmatrix} u$$

$$y = [1 \ 0] \begin{bmatrix} x_1 \\ x_2 \end{bmatrix}$$

- (i) Check whether the system is observable or not.
- (ii) Find the state transition matrix.
- (iii) Design a state feedback controller to place closed-loop poles at  $-1 \pm 2j$ .

20

\*\*\*