



GATE | PSUs

MECHANICAL

ENGINEERING



MECHANICAL ENGINEERING

THERMAL ENGINEERING

Volume-1 : Study Material with Classroom Practice Questions

Thermodynamics

Solutions for Volume - I - Classroom Practice Questions

Chapter- 1 Basic Concepts

01. Ans: (d)

Sol: $\frac{dT}{T} - \frac{V}{T}dP$

$$= \frac{1}{T}dT - \frac{V}{T}dP \quad \left(PV = RT, \frac{V}{T} = \frac{R}{P} \right)$$

$$= \frac{1}{T}dT - \frac{R}{P}dP$$

$$= MdT + NdP$$

$$M = \frac{1}{T}; N = -\frac{R}{P}$$

$$\frac{\partial M}{\partial P} = 0; \frac{\partial N}{\partial T} = 0$$

$$\therefore \frac{\partial M}{\partial P} = \frac{\partial N}{\partial T} \text{ hence it is a property}$$

02. Ans: (a)

Sol: Volume → Extensive property

Density → Intensive Property

Pressure → Point function

Work → Path function

Energy → Point function

03. Ans: (b)

Sol: A real gas obeys perfect gas law at very high temperature and low pressure.

04. Ans: (b)

Sol: $F + P = C + 2$

No. of components, $C = 2$

No. of phases, $P = 2$

$$\therefore F + 2 = 2 + 2$$

$$\Rightarrow F = 2$$

05. Ans: (d)

Sol: When molecular momentum of system becomes zero, the pressure reaches its absolute zero values.

06. Ans: (b)

Sol: Final equilibrium temperature can be calculated by using conservation of energy i.e., first law of thermodynamics.

07. Ans: (b)

Sol: Mole fraction of $N_2 = \frac{n_{N_2}}{\text{Total no. of moles}}$

$$0.3 = \frac{n_{N_2}}{1}$$

$$n_{N_2} = 0.3$$

$$m_{N_2} = n_{N_2} \times \text{molecular weight}$$

$$= 0.3 \times 28 = 8.4 \text{ kg}$$

$$\text{Mass fraction of } N_2 = \frac{m_{N_2}}{\text{Total mass}}$$

$$= \frac{8.4}{36} = 0.233$$



08. Ans: (d)

$$\text{Sol: } m_{N_2} = n_{N_2} \times (\text{molar weight}) = 2 \times 28 \\ = 56 \text{ kg}$$

$$m_{CO_2} = n_{CO_2} \times (\text{molecular weight}) = 6 \times 44 \\ = 264 \text{ kg}$$

$$m_{N_2} + m_{CO_2} = 320 \text{ kg}$$

$$\text{Mass fraction} = \frac{m_{CO_2}}{m_{CO_2} + m_{N_2}} \\ = \frac{264}{320} = 0.825$$

09. Ans: (a)

$$\text{Sol: } m_{N_2} = n_{N_2} \times (\text{molar weight}) \\ = 2 \times 28 = 56 \text{ kg}$$

$$m_{CO_2} = n_{CO_2} \times (\text{molecular weight}) \\ = 4 \times 44 = 176 \text{ kg}$$

$$R_{N_2} = \frac{\bar{R}}{\text{Molecular weight}} = \frac{8.314}{28} \\ = 0.2969 \text{ kJ/kg.K}$$

$$R_{CO_2} = \frac{\bar{R}}{\text{molecular weight}} = \frac{8.31}{44} \\ = 0.1889 \text{ KJ/kg.K}$$

$$R_{\text{mixture}} = \frac{m_{N_2} \times R_{N_2} + m_{CO_2} \times R_{CO_2}}{m_{N_2} + m_{CO_2}} \\ = \frac{56 \times 0.2969 + 176 \times 0.1889}{56 + 176} \\ = 0.215 \text{ kJ/kg.K}$$

10. Ans: (b)

Sol: For N₂

$$n_1 = 3$$

$$P_1 = 600 \text{ kPa}$$

$$n = n_1 + n_2 = 10$$

$$P_f = 300 \text{ kPa}$$

$$P_{N_2} = \left(\frac{n_1}{n_1 + n_2} \right) P_f = \left(\frac{3}{10} \right) \times 300 \\ = 90 \text{ kPa}$$

For CO₂

$$n_2 = 7$$

$$P_2 = 200 \text{ kPa}$$

11. Ans: (d)

Sol: V = 80 L

$$n = n_{N_2} + n_{CO_2} \\ = \frac{5}{28} + \frac{5}{44}$$

$$PV = n \bar{R} T$$

$$\frac{P}{\bar{R} T} = \frac{n}{V} = \frac{\left(\frac{5}{28} + \frac{5}{44} \right)}{80}$$

$$P_1 V_1 = n_1 \bar{R} T$$

$$\frac{P}{\bar{R} T} = \frac{n_1}{V_1} = \frac{\left(\frac{5}{28} \right)}{V_1} = \frac{\left(\frac{5}{28} + \frac{5}{44} \right)}{80} \\ \Rightarrow V_1 = 48.88 \text{ L}$$

12. Ans: (b)

Sol: For Argon:

$$m = 3 \text{ kgs}$$

$$\text{Molar weight} = 40$$

$$\gamma = \frac{5}{3} \text{ (monoatomic)}$$



$$(C_V)_{Ar} = \frac{\bar{R}}{M(\gamma-1)} = \frac{8.314}{40\left(\frac{5}{3}-1\right)}$$

$$= 0.311 \text{ kJ/kg.K}$$

For CO₂:

$$m = 6 \text{ kgs, Molar weight} = 44, \gamma = \frac{4}{3}$$

$$(C_V)_{CO_2} = \frac{\bar{R}}{M(\gamma-1)} = \frac{8.314}{44\left(\frac{4}{3}-1\right)}$$

$$= 0.566 \text{ kJ/kg.K}$$

$$(C_V)_{mix} = \frac{m_{Ar} \times (C_V)_{Ar} + m_{CO_2} \times (C_V)_{CO_2}}{m_{Ar} + m_{CO_2}}$$

$$= \frac{(3 \times 0.31) + (6 \times 0.566)}{3 + 6}$$

$$= 0.4806 \text{ kJ/kg.K}$$

$$Q_S = m \times (C_V)_{mix} \times (\Delta T)$$

$$= (3 + 6) \times 0.4806 \times (350 - 250)$$

$$= 432.6 \text{ kJ}$$

13. Ans: (b)

Sol: $P_1 = 1.2 \text{ MPa}, P_2 = 0.2 \text{ MPa}$

He = 30%, Ar = 70%

Adiabatic process, $\gamma = \frac{5}{3}$ (monatomic)

$$\frac{T_2}{T_1} = \left(\frac{P_2}{P_1}\right)^{\frac{\gamma-1}{\gamma}}$$

$$T_2 = 673 \times \left(\frac{0.2}{1.2}\right)^{\frac{\frac{5}{3}-1}{\frac{5}{3}}} = 328.7 \text{ K} = 55.7^\circ \text{C}$$

14. Ans: (d)

Sol: For He: $n_1 = 3, \gamma = \frac{5}{3}$

$$(C_P)_{He} = \frac{\gamma \bar{R}}{(\gamma-1)} = \frac{\frac{5}{3} \times 8.314}{\left(\frac{5}{3}-1\right)} = 20.78 \text{ kJ/kg.K}$$

For Ar:

$$n_2 = 7, \gamma = \frac{5}{3}$$

$$(C_P)_{Ar} = \frac{\gamma \bar{R}}{(\gamma-1)} = \frac{\frac{5}{3} \times 8.314}{\left(\frac{5}{3}-1\right)} = 20.78 \text{ kJ/kg.K}$$

$$(C_P)_{Mix} = \frac{n_{He}(C_P)_{He} + m_{Ar}(C_P)_{Ar}}{n_{He} + n_{Ar}}$$

$$= \frac{3 \times 20.79 + 7 \times 20.79}{3 + 7}$$

$$= 20.79 \text{ kJ/kg.K}$$

$$\frac{V_1}{T_1} = \frac{V_2}{T_2}$$

$$T_2 = \frac{V_2}{V_1} \times T_1$$

$$= 2 \times 323 = 646 \text{ K}$$

$$Q_S = n \times (C_P)_{mix} \times (\Delta T)$$

$$= (3+7) \times 20.79 \times (646 - 323) = 67 \text{ MJ}$$

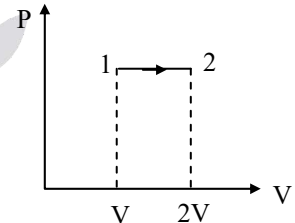

15. Ans: 2.67 cm of Hg

Sol: At ground

$$\text{Balloon volume, } V_1 = \frac{4}{3} \pi r^3$$

$P_1 = 72 \text{ cm of Hg.}$

In the air, $R = 3r$



Balloon volume, $V_2 = 27 \times \frac{4}{3} \pi r^3$

Temperature constant \Rightarrow Isothermal

\Rightarrow Process $P_1 V_1 = P_2 V_2$

$\Rightarrow P_2 = 72 r^3 / 27 r^3 = 2.67 \text{ cm of Hg}$

16. Ans: $P_1 > P_2$

Sol: For isothermal process: $T = c$

$\Rightarrow P_1 V_1 = P_2 V_2$

$$P_2 = P_1 \left(\frac{V_1}{V_2} \right)$$

As per fig we can say $T_1 > T_2$

$\Rightarrow P_1 > P_2 \dots \dots \left(\frac{V_1}{V_2} < 1 \right)$

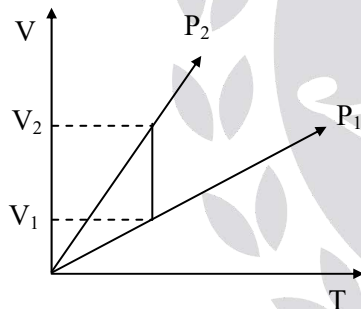

(2) For isochoric : $V = C$

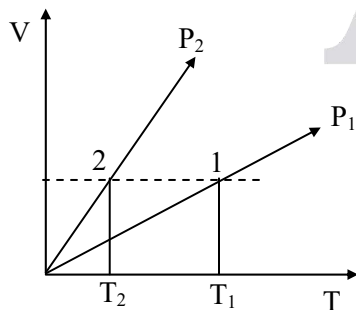

$$\frac{P_1}{T_1} = \frac{P_2}{T_2}$$

$T_1 > T_2$

$\therefore P_2 = \left(\frac{T_2}{T_1} \right) P_1$

$\therefore P_2 < P_1$

17. Ans: (d)

Sol: LFP = Lower fixed point

UFP = upper fixed point

$$\frac{C - \text{LFP}}{\text{UFP} - \text{LFP}} = \frac{0 - 300}{100 - 300}$$

$$\frac{C - 0}{100 - 0} = \frac{0 - 300}{100 - 300}$$

$C = 150^\circ\text{C}$

18. Ans: 26.77°C

Sol: $t_A = a + bt_B + ct_B^2$

$t_A = 0^\circ\text{C}; t_B = 0^\circ\text{C}$

$t_A = 100^\circ\text{C}; t_B = 100^\circ\text{C}$

$t_A = 51^\circ\text{C}; t_B = 50^\circ\text{C}$

$0 = a + b \times 0 + c \times 0$

$\therefore a = 0$

$100 = 100b + 10^4 c \times 1$

$51 = 50 b + 2500 c \times 2$

$102 = 100 b + 5000 c$

$100 = 100b + 10000 c$

$- 5000 c = 2$

$$c = \frac{-2}{5000} = -4 \times 10^{-4}$$

$50 b + 2500 c = 51$

$50b + 2500 \times (-4 \times 10^{-4}) = 51$

$50 b = 51 + 1$



$$b = \frac{52}{50} = 1.04$$

$$\therefore t_A = 1.04 t_B - 4 \times 10^{-4} t_B^2$$

$$t_B = 26^\circ\text{C}$$

$$\begin{aligned} t_A &= 1.04 \times 26 - 4 \times 10^{-4} \times 26^2 \\ &= 27.04 - 0.2704 \\ &= 26.77^\circ\text{C} \end{aligned}$$

Unless the constructional features of thermometer are given it is difficult to say which thermometer is correct.

19. Ans: 21.6°C

Sol: Given relation $t = a/\ln(K) + b$

$$K \text{ is } 1.83 \text{ at ice point} \Rightarrow t = 0^\circ\text{C}$$

$$K \text{ is } 6.78 \text{ at steam point} \Rightarrow t = 100^\circ\text{C}$$

$$\text{As per given relation, } t = a/\ln(K) + b$$

$$\text{By condition 1} \Rightarrow 0 = a/\ln(1.83) + b$$

$$0 = 0.60 a + b$$

$$\text{By condition 2} \Rightarrow 100 = a/\ln(6.78) + b$$

$$100 = a \cdot 1.914 + b \Rightarrow a = 76.10$$

$$b = -45.66$$

\Rightarrow By putting value of a & b

$$t = 76.10/\ln K - 45.66$$

$$(K = 2.42 \text{ given})$$

$$\Rightarrow t = 21.6^\circ\text{C}$$

20. Ans: 550°N, -50°C

Sol: Freezing point of ice = $0^\circ\text{C} = 100^\circ\text{N}$

$$\text{Boiling point} = 100^\circ\text{C} = 400^\circ\text{N}$$

Let new scale be given as

$$N = a t + b$$

$$100 = a(0) + b$$

$$\therefore b = 100$$

$$400 = 100 a + b$$

$$\therefore a = 3$$

when $t = 150^\circ\text{C}$

$$N = 3(150) + 100$$

$$N = 550^\circ\text{N}$$

The new scale N and Celsius will be same if

$$t = 3 t + 100$$

$$-2t = 100$$

$$\therefore t = -50^\circ\text{C}$$



Chapter- 2
Work and Heat

01. Ans: (c)

Sol: Heat engine cycles as shown in fig

$$VQ = QR, \quad PQ = QS,$$

$$UP = PR = RT$$

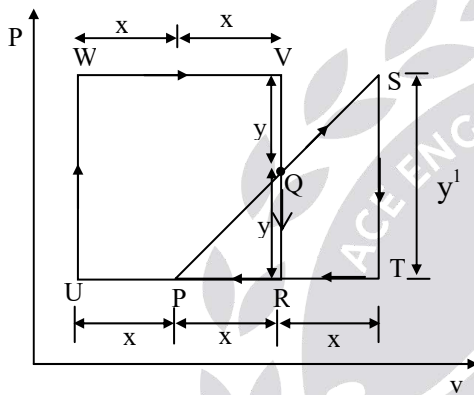

Work interaction for 'WVUR' = 48 Nm

$$\text{Area WVUR} = 2x \times 2y = 48$$

$$\Rightarrow xy = 12$$

From similar Δ^{les} PQR and PST

$$\frac{QR}{PR} = \frac{ST}{PT}$$

$$\frac{y}{x} = \frac{y'}{2x} \Rightarrow y' = 2y$$

Work interaction for Δ^{le} 'PST'

$$\frac{1}{2}(2x)y' = \frac{1}{2}(2x)(2y) = 2xy$$

$$= 2 \times 12 = 24 \text{ Nm}$$

02. Ans: (d)

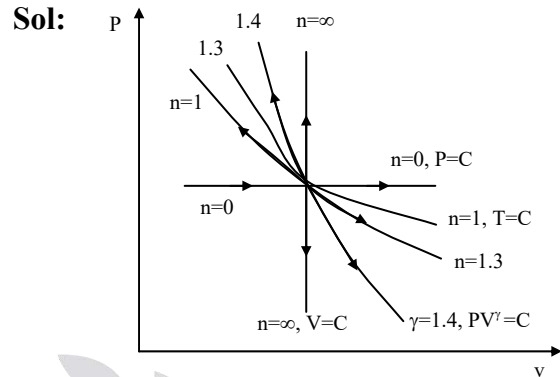

03. Ans: (b)

Sol: Process	1	2	3	4
dQ(kJ)	300	0	-100	0
dW(kJ)	300	250	-100	-250

Heat supplied $Q_S = 300 \text{ kJ}$

Work of expansion, $W_E = 300 + 250 = 550 \text{ kJ}$

Work of compression, $W_C = 100 + 250 = 350 \text{ kJ}$

$$W_{net} = W_E - W_C = 550 - 350 = 200 \text{ kJ}$$

$$\eta_{thermal} = \frac{W_{net}}{\text{Heat supplied}} = 0.67$$

$$\text{Work ratio} = \frac{W_{net}}{W_E} = \frac{200}{550} = 0.36$$

04. Ans: (c)

Sol: (A) W.D in polytropic process

$$= \frac{(P_1 V_1 - P_2 V_2)}{(n-1)}$$

(B) W.D in steady flow process = $-\int v dP$

(C) Heat transfer in reversible adiabatic process = zero

(D) W.D in an isentropic process

$$= \frac{P_1 V_1 - P_2 V_2}{(\gamma-1)}$$



05. Ans: (d)

Sol: Given

For isothermal process

$$P_1 V_1 = P_2 V_2$$

$$\Rightarrow P_1 V_1 = \frac{P_1}{10} \times 0.55$$

$$\Rightarrow V_1 = 0.055 \text{ m}^3$$

For adiabatic process

$$P_1 V_1^\gamma = P_2 V_2^\gamma$$

$$\Rightarrow P_1 V_1^{1.4} = \frac{P_1}{10} \times V_2^{1.4}$$

$$\Rightarrow V_2^{1.4} = 10 \times (0.055)^{1.4} \Rightarrow V_2 = 0.284 \text{ m}^3$$

06. Ans: (b)

Sol:

- Adiabatic $\rightarrow n = \frac{c_p}{c_v}$
- Isothermal $\rightarrow n = 1$
- Constant pressure $\rightarrow n = 0$
- Constant volume $\rightarrow n = \infty$

07. Ans: (d)

Sol: No. of degrees of freedom in diatomic molecule = 5

No. of degrees of freedom in monoatomic molecule = 3

No. of degrees of freedom in Triatomic molecule = 6 or 7

08. Ans: (a)

Sol: The slope of $\log P - \log V$ graph for a gas for isothermal change is m_1 & for adiabatic changes are m_2 if gas is diatomic gas

For isothermal process, $PV = C$

$$\log(P) + \log(V) = \log(C)$$

$$\log(P) = \log(C) - \log(V)$$

Compare it with $y = C + mx$

$$m_1 = -1$$

For adiabatic process

$$PV^\gamma = C$$

$$\Rightarrow \log P + \gamma \log V = \log C$$

$$\Rightarrow \log(V) = \log C - \gamma \log V$$

Compare with $y = C + mx$

$$m_2 = -\gamma$$

$$\Rightarrow m_1 < m_2$$

09. Ans: (d)

Sol: The ratio of C_p/C_v for a gas with n degrees of freedom is equal to $1 + \frac{2}{n}$

10. Ans: (c)

Sol: C_p ; C_v ; γ ; values are constant for ideal gases
 C_p ; C_v values increase with temperature for Real gases.

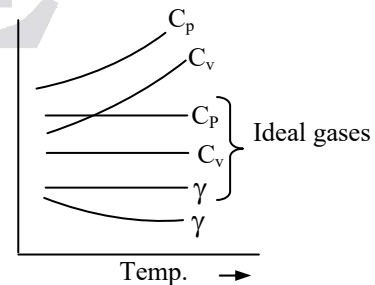

Where as “ γ ” value decreases with temperature.



11. Ans: (b)

Sol: $P = 320\text{W}$

In 30 days the refrigeration runs is

$$= 30 \times \frac{1}{4} = 7.5 \text{ days}$$

So total consumption of a month in Watt-hr is

$$= 320 \times 7.5 \times 24 = 57600 \text{ W-hr}$$

$$= 57.6 \text{ kWhr}$$

So the electricity cost per month

$$= 57.6 \times 0.09 = \$ 5.184$$

12. Ans: (a)

Sol: $m_1 = 6\text{kg}$; $P_1 = 3\text{atm}$

$T_1 = 40^\circ\text{C} = 313\text{K}$, $P_2 = 2.2\text{atm}$

$$P_1 V_1 = m_1 R T_1$$

$$P_2 V_2 = m_2 R T_2$$

As the tank is rigid, the volume is constant

$$\Rightarrow \frac{P_1}{P_2} = \frac{m_1 T_1}{m_2 T_2}$$

$$\Rightarrow T_2 = \frac{m_1 \times P_2 \times T_1}{P_1}$$

$$\Rightarrow T_2 = \frac{6 \times 2.2 \times 313}{3 \times 3} = 460 \text{ K} = 187^\circ\text{C}$$

13. Ans: (d)

Sol: Work done = Area enclosed in Pv diagram

$$W = \text{Area of } \triangle ADC + \text{Area of } \triangle ABC$$

$$\text{Area of } \triangle ADC = \frac{1}{2} \times (6 - 2) \times (4 - 1)$$

$$= 6 \text{ bar-m}^3 = 600 \text{ kN-m}$$

$$\text{Area of } \triangle ABC = \frac{1}{2} \times (6 - 2) \times (6 - 4)$$

$$= 400 \text{ kN-m}$$

$$\therefore W = (600 + 400) \text{ kN-m} = 1000 \text{ kN-m}$$

14. Ans: (d) &

15. Ans: (c)

Sol: $P_1 = 100 + 101.325 = 201.325 \text{ kPa}$

$$T_1 = 288 \text{ K},$$

$$V_1 = 2500 \text{ C.C}$$

$$m = \frac{P_1 V_1}{R T_1} = \frac{201.325 \times 10^3 \times 2500 \times 10^{-6}}{287 \times 288}$$

$$= 6.089 \times 10^{-3} \text{ kg}$$

As volume is constant, $dW = 0$

$$\therefore dQ = dU = m C_v dT$$

$$= 6.089 \times 10^{-3} \times 0.718 \times 10^3 (15 - 5)$$

$$= 43.7 \text{ J}$$

$$\frac{P_1}{T_1} = \frac{P_2}{T_2}$$

$$P_2 = \text{Pressure on day of play} = P_1 \times \frac{T_2}{T_1}$$

$$= 201.325 \times \frac{278}{288}$$

$$= 194.33 \text{ kPa (absolute)}$$

Gauge pressure on day of play

$$= 194.33 - 101.325$$

$$= 93 \text{ kPa} = 0.93 \text{ bar}$$

$P_1 =$ Pressure to which it must be inflated

$$\frac{P_1}{T_1} = \frac{P_2}{T_2}$$

$$\frac{P_1}{288} = \frac{201.325}{278}$$



$$P_1 = 201.325 \times \frac{288}{278} = 208.56 \text{ kPa.}$$

Gauge pressure to which it must be inflated on previous day
 $= 208.56 - 101.3$
 $= 107.24 \text{ kPa} = 1.07 \text{ bar}$

16. Ans: (a)

Sol: Work done in isothermal process

$$= P_1 V_1 \ln \frac{V_2}{V_1}$$

$$= 500 \times 0.8 \times \ln \left(\frac{0.1}{0.8} \right) = -831.77 \text{ kJ}$$

17. Ans: 251.62 kJ

Sol: $m = 1.5 \text{ kg}$, $P_1 = 0.1 \text{ MPa}$,
 $\rho_1 = 1.16 \text{ kg/m}^3$, $P_2 = 0.7 \text{ MPa}$

$$W = P_1 V_1 \ln \left(\frac{V_2}{V_1} \right) = P_1 V_1 \ln \left(\frac{P_2}{P_1} \right)$$

$$V_1 = \frac{m}{\rho_1} = 1.293 \text{ m}^3$$

$$W = 0.1 \times 1000 \times 1.293 \times \ln \left(\frac{0.1}{0.7} \right)$$

$$= -251.62 \text{ kJ}$$

\therefore Work done by piston is 251.62 kJ

18. Ans: 130.16 kJ/kg

Sol:

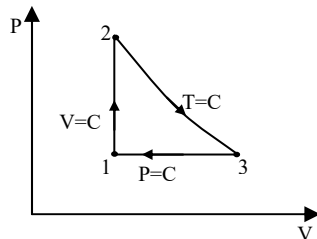

1 - 2 Process

$$T_1 = 350 \text{ K}$$

$$\frac{T_2}{T_1} = 3 = \frac{P_2}{P_1}$$

$$T_2 = 3 \times 350 = 1050 \text{ K}$$

$${}_1W_2 = 0$$

2 - 3 Process

$${}_2Q_3 = {}_2W_3 = RT_2 \ln \frac{P_2}{P_3}$$

$$= RT_2 \ln 3$$

$$= R(1050 \ln 3) = 1153.54R \frac{\text{kJ}}{\text{kg}}$$

1 - 3 Process

$$P = C$$

$$\frac{V_3}{T_3} = \frac{V_1}{T_1}; \frac{V_3}{V_1} = \frac{T_3}{T_1} = \frac{T_2}{T_1} = 3$$

$$\text{As } T_3 = T_2$$

$${}_3W_3 = P(V_1 - V_3) = RT_3 \left(\frac{T_1}{T_3} - 1 \right)$$

$$= 1050R \left(\frac{1}{3} - 1 \right)$$

$$= -700R \text{ kJ/kg}$$

$$W_{\text{net}} = {}_1W_2 + {}_2W_3 + {}_3W_1$$

$$= 0 + 1153.54R - 700R$$

$$= 453.54R \text{ kJ/kg}$$

$$= 453.54 \times 0.287 = 130.16 \text{ kJ/kg}$$



19. Ans: 2356.2 kJ/kg

Sol: $(1\text{cm})_x = 300 \text{ kPa}$

$$(1\text{ cm})_y = 0.1 \text{ m}^3/\text{kg}$$

$$1 \text{ cm}^2 \text{ Area} = (1\text{cm})_x \times (1\text{cm})_y \\ = 300 \times 0.1 = 30 \text{ kJ/kg}$$

$$\text{Area on P-V diagram} = A = \frac{\pi}{4} D^2$$

$$= \frac{\pi}{4} \times 10^2$$

$$= 78.5 \text{ cm}^2$$

$$\text{Net work} = 78.5 \text{ cm}^2$$

$$= 78.5 \times 30 = 2355 \text{ kJ/kg}$$

20. Ans: 29.7 kJ

Sol: $A = 0.12 \text{ m}^2$

$$P_1 = 1.5 \text{ MPa} = 1500 \text{ kPa}$$

$$P_2 = 0.15 \text{ MPa} = 150 \text{ kPa}$$

$$l = 0.3 \text{ m}$$

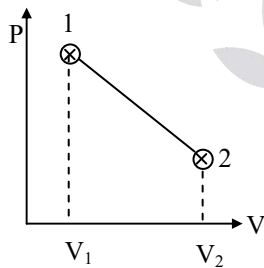

$${}_1W_2 = \frac{1}{2}(P_1 + P_2)V_s, \quad V_s = V_2 - V_1$$

$$\Rightarrow {}_1W_2 = \frac{1}{2} \times (1500 + 150) \times (0.036)$$

$$(\because V_s = Al = 0.12 \times 0.3 = 0.036 \text{ m}^3)$$

$$\Rightarrow {}_1W_2 = 29.7 \text{ kJ}$$

21. Ans: 1742 kJ

Sol: Given $\left[P + \frac{a}{V^2} \right] (V - b) = mRT$

$$P + \frac{a}{V^2} = \frac{mRT}{(V - b)}$$

$$P = \frac{mRT}{(V - b)} - \frac{a}{V^2}$$

$$W.D = \int_{V_1}^{V_2} P dV = \int_{V_1}^{V_2} \left[\frac{mRT}{(V - b)} - \frac{a}{V^2} \right] dV$$

$$W.D = mRT \ln[V - b]_{V_1}^{V_2} - a \left[\frac{V^{-2+1}}{-2+1} \right]_{V_1}^{V_2}$$

$$W.D = mRT \ln \left(\frac{V_2 - b}{V_1 - b} \right) + a \left[\frac{1}{V_2} - \frac{1}{V_1} \right]$$

$$m = 10 \text{ kg}, \quad V_1 = 1 \text{ m}^3,$$

$$V_2 = 10 \text{ m}^3, \quad T = 293 \text{ K},$$

$$a = 15.7 \times 10^4 \text{ Nm}^4 = 157 \text{ kNm}^4$$

$$b = 1.07 \times 10^{-2}, \quad R = 0.278 \text{ kJ/kg.K}$$

$$W.D = (10)(0.278)(293)$$

$$+ \ln \left(\frac{10 - (1.07 \times 10^{-2})}{1 - (1.07 \times 10^{-2})} \right) + 157 \left[\frac{1}{10} - 1 \right]$$

$$W.D = 1742.14 \text{ kJ}$$

22. Ans: 686.62 kJ

Sol: $P \propto D^2$

$$P_1 = KD_1^2$$

$$P_2 = KD_2^2$$

$$P_1 = 100 \text{ kPa}, \quad D_1 = 1 \text{ m}$$

$$\therefore K = 100 \text{ kPa/m}^2$$

$$P_2 = 350 \text{ kPa},$$

$$D_2 = ?$$



$$\frac{P_1}{P_2} = \frac{D_1^2}{D_2^2}$$

$$D_2 = D_1 \sqrt{\frac{P_2}{P_1}}$$

$$= 1 \sqrt{\frac{350}{100}} = 1.8708 \text{ m}$$

Volume of balloon

$$V = \frac{4}{3} \pi R^3 = \frac{4}{3} \pi \times \left(\frac{D}{2}\right)^3$$

$$= \frac{4}{3} \times \pi \times \frac{D^3}{8}$$

$$V = \frac{\pi}{6} D^3$$

$$dV = 3 \times \frac{\pi}{6} D^2 dD$$

$$= \frac{\pi}{2} D^2 dD$$

$${}_1W_2 = \int_{D_1}^{D_2} PdV = \int_{D_1}^{D_2} KD^2 \times \frac{\pi}{2} D^2 dD$$

$$= \int_{D_1}^{D_2} \frac{K}{2} \pi D^4 dD$$

$$= \int_1^{1.8708} \frac{100}{2} \times \pi \times D^4 dD$$

$$= 50\pi \frac{D^5}{5} \Big|_1^{1.8708}$$

$${}_1W_2 = 10\pi [1.8708^5 - 1^5]$$

$$= 10\pi [22.9159 - 1] = 688.16 \text{ kJ}$$

23. Ans: 116.67 kPa, 54.42 kJ

Sol: Given, $m_w = 500 \text{ kg}$

Total tank volume, $V = 4 \text{ m}^3$

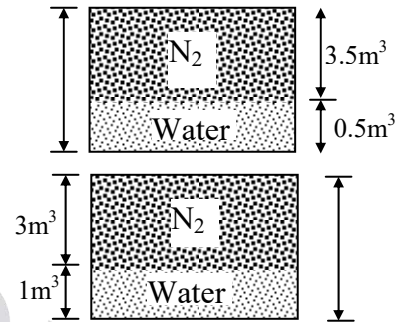

$P_1 = 100 \text{ kPa}$

$m_w = 500 \text{ kg}$, $\rho_w = 1000 \text{ kg/m}^3$

For state-1, $V = \frac{500}{1000} = 0.5 \text{ m}^3$

For state-2, $m_w = 1000 \text{ kg}$, $V = 1 \text{ m}^3$

For state 1 ('N₂'):

$P_1 = 100 \text{ kPa}$

$V_1 = \text{Total volume} - \text{vol. of water}$
 $= 4 - 0.5 = 3.5 \text{ m}^3$

For state 2 ('N₂'):

$V_2 = \text{Total volume} - \text{vol. of water}$
 $= 4 - 1 = 3 \text{ m}^3$

Condition: Isothermal process

\Rightarrow From eqⁿ $P_1 V_1 = P_2 V_2$

$\Rightarrow P_2 = \frac{P_1 V_1}{V_2} = \frac{100 \times 3.5}{3}$

$\Rightarrow P_2 = 116.67 \text{ kPa}$

${}_1W_2 = P_1 V_1 \ln\left(\frac{V_2}{V_1}\right) = 100 \times 3.53 \times \ln\left(\frac{3}{3.5}\right)$

$\Rightarrow W = -54.42 \text{ kJ}$

Here '-ve' sign indicates compression of N₂
 so system volume decreases

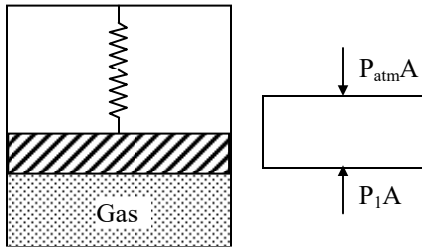
24. Ans: 320 kPa, 13 kJ
Sol:

$$V_1 = 0.05 \text{ m}^3, \quad P_1 = 200 \text{ kPa},$$

$$A_p = 0.25 \text{ m}^2,$$

 Spring constant, $k = 150 \text{ kN/m}$

$$V_2 = 2V_1 = 2 \times 0.05 = 0.1 \text{ m}^3$$

$$dx = \frac{V_2 - V_1}{A} = \frac{0.1 - 0.05}{0.25} = 0.2 \text{ m}$$

$$P_1 A = P_{\text{atm}} A$$

$$P_1 = P_{\text{atm}}$$

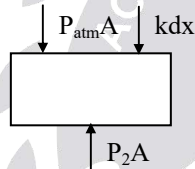

Final force = Initial force + spring force

$$P_2 A = P_1 A + k dx$$

$$P_2 = P_1 + k \frac{dx}{A}$$

$$= 200 + 150 \times \frac{(0.2)}{0.25}$$

$$= 200 + 120 = 320 \text{ kPa}$$

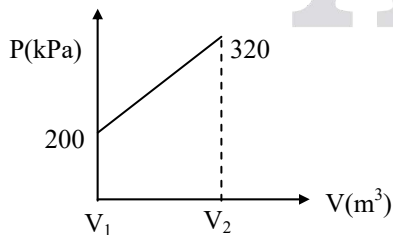

$$\text{Work done} = \frac{1}{2} (320 + 200) \times 0.05 = 13 \text{ kJ}$$

25. Ans: 2.5 kJ
Sol: Given $P_a = 0.1 \text{ MPa} = 100 \text{ kPa}$

$$V_1 = 0.01 \text{ m}^3; \quad A_1 = 0.05 \text{ m}^2$$

$$\Rightarrow l_1 = \frac{V_1}{A_1} = \frac{0.01}{0.05} \Rightarrow l_1 = 0.2 \text{ m}$$

$$V_2 = 3V_1$$

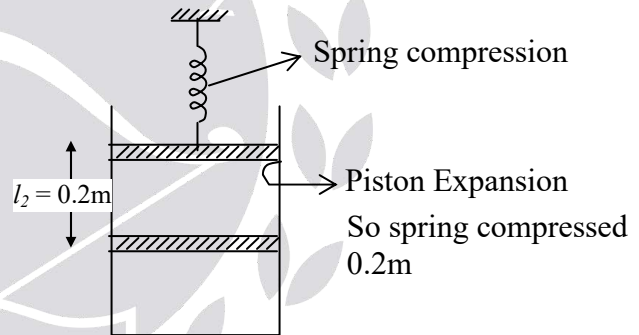
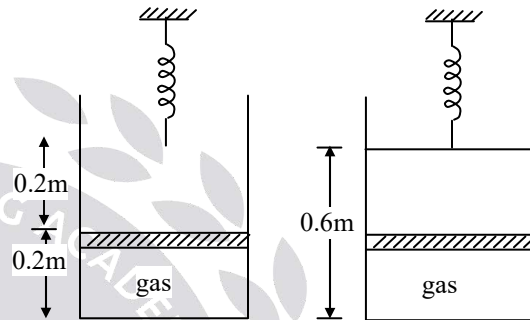
Find: Total W.D

Here rigid cylinder so area will be same

$$A l_2 = 3 A l_1$$

$$l_2 = 3 l_1$$

$$\Rightarrow l_2 = 0.6 \text{ m}$$

$$\Rightarrow V_2 = 0.03 \text{ m}^3$$

Total work = [work of gas + (work of spring due to expansion by heating)]

(Due to expansion of piston, spring is compressed)



$$= PdV + \frac{1}{2}Kx^2$$

$$= P(V_2 - V_1) + \frac{1}{2}(25)(0.2)^2$$

[∵ constant pressure process]

$$= 100(0.03 - 0.01) + \frac{1}{2}(0.2)^2(25)$$

Total work = 2.5 kJ

26. Ans: 0.79 N-m, 6.95 W

Sol:

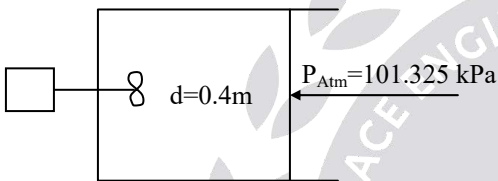

$d = 0.4 \text{ m}$, time = 600 sec

$W = 2 \text{ kJ}$, $l = 0.485 \text{ m}$, $N = 840 \text{ rpm}$

$W_{\text{Net}} = \text{Piston expansion work} - W_{\text{Stirrer}}$

$$2 = PdV - W_s$$

$$2 = (101.325)Al - W_s$$

$$2 = (101.325) \left(\frac{\pi}{4} (0.4)^2 \times 0.485 \right) - W_s$$

$W_s = 4.175 \text{ kJ}$

$$\Rightarrow \text{Power} = \frac{W_s}{\text{Time}} = \frac{4.175}{600}$$

$$= 6.95 \times 10^{-3} \text{ kW} = 6.95 \text{ W}$$

$$\text{Now, } P_s = \frac{2\pi NT}{60}$$

$$T = \frac{60P_s}{2\pi N} = \frac{60(6.95)}{2 \times 3.14 \times 840}$$

$\Rightarrow T = 0.079 \text{ Nm}$

Chapter- 3 First Law of Thermodynamics

01. Ans: (c)

Sol:

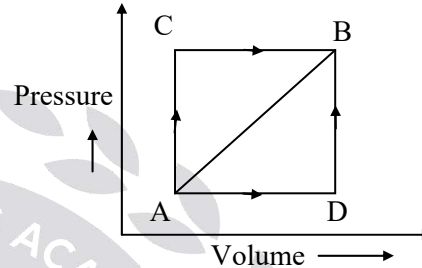

Along A - B - C:

$$Q_{A-B} - W_{A-B} = U_{A-B}$$

$$180 - 130 = U_B - U_A$$

$$U_B - U_A = 50 \text{ kJ}$$

Along A - D - B:

$$Q_{A-B} - W_{A-B} = U_{A-B}$$

$$Q_{A-B} = 50 + 40 = 90 \text{ kJ}$$

02. Ans: -200 kJ

Sol: For 1-2 process

$${}_1Q_2 - {}_1W_2 = {}_1U_2$$

$$\Rightarrow 100 - 100 = U_2 - U_1$$

$$\Rightarrow U_2 = U_1$$

For 2-3 process

$${}_2Q_3 - {}_2W_3 = {}_2U_3$$

$$\Rightarrow -150 - {}_2W_3 = U_3 - U_2 = U_3 - U_1 = 200$$

$${}_2W_3 = -350 \text{ kJ}$$



For 3 – 4 process

$${}_3Q_4 - {}_3W_4 = {}_3U_4$$

$$\begin{aligned} {}_3U_4 &= (U_4 - U_3) = (U_4 - U_1) - (U_3 - U_1) \\ &= -(U_1 - U_4) - (U_3 - U_1) \\ &= -50 - 200 = -250 \end{aligned}$$

$${}_3Q_4 = {}_3U_4 - 250 \dots\dots\dots (1)$$

For 4 – 1 Process

$${}_4Q_1 - {}_4W_1 = {}_4U_1 = U_1 - U_4$$

$${}_4Q_1 - 300 = 50$$

$${}_4Q_1 = 350 \text{ kJ}$$

$$\begin{aligned} \Sigma Q &= {}_1Q_2 + {}_2Q_3 - {}_3Q_4 + {}_4Q_1 \\ &= 100 - 150 - 500 + 350 = -200 \text{ kJ} \end{aligned}$$

$$(\because \Sigma Q = \Sigma W)$$

$$\Sigma W = 100 - 350 - 250 + 300 = -200 \text{ kJ}$$

03. Ans: (c)

Sol: (a) $dW = 0$ (Rigid)

$$dQ = -ve$$

$$dU = -ve$$

$$dQ - dW = dU$$

$$dU = -ve$$

(b) $dQ = 0$ (Insulated)

$$dW = +ve \text{ (Expansion)}$$

$$\therefore dQ - dW = dU$$

$$0 - dW = dU$$

$$dU = -ve$$

(c) $dW = 0$ (Free expansion)

$$dQ = 0 \text{ (Insulated)}$$

$$\Rightarrow dU = 0$$

(d) $dW = -ve$

$$dQ = 0 \text{ (Adiabatic)}$$

$$dU = +ve$$

04. Ans: (e)

Sol: $m = 60 \text{ kg}$, $P = 200 \text{ kPa}$

$$T = 25^\circ\text{C} , \quad \frac{dQ}{dt} = 0.8 \text{ kW}$$

$$t = 30 \text{ min} = 1800 \text{ sec}$$

Well sealed = control mass

(Non flow process)

$$dQ - dW = dU$$

$$\frac{dQ}{dt} \times t - \frac{dW}{dt} \times t = mC_v dT$$

$$1800[0.8 - (-0.12)] = 60(0.718)(T - 25)$$

$$T = 63.4^\circ\text{C}$$

05. Ans (d)

Sol: $Q = 2000 \text{ W}$

$$t = 15 \text{ min} = 900 \text{ sec}$$

$$m = 75 \text{ kg}$$

Well sealed = control mass (Non flow process)

$$dQ - dW = dU$$

$$\frac{dQ}{dt} \times t - \frac{dW}{dt} \times t = mC_v dT$$

$$t \left(\frac{dQ}{dt} - \frac{dW}{dt} \right) = mC_v dT$$

$$900 [0 - (-2)] = 75(0.718)dT$$

$$dT = 33.42^\circ\text{C}$$



06. Ans: (c)

Sol: $P_1 = -0.25$ kW (– ve sign indicates it is a power consuming device)

$$P_2 = -0.12 \text{ kW}$$

$$P_3 = -1 \text{ kW}$$

$$P_4 = -0.05 \text{ kW}$$

Temperature = constant

(Isothermal process)

$$dQ = dW \quad (\because dU = 0)$$

$$dQ = -(0.25 + 0.12 + 1 + 0.05) \times 3600$$

$$= -5112 \text{ kJ/hr}$$

07. (i) Ans: (b), (ii) Ans: (c)

Sol:

(ii) Ideal gas stored in Rigid insulated Tank.

Total volume of Tank $V_f = 3\text{m}^3$

State : 1

Tank has two compartments.

State : 2

Partition between two compartments

Ruptured

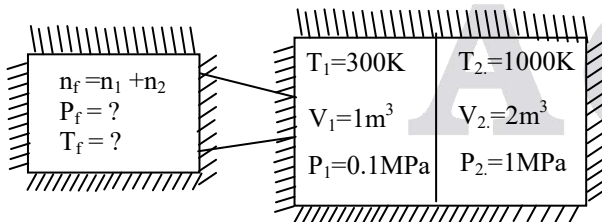

$$PV = mRT$$

$$\Rightarrow PV = m \frac{\bar{R}T}{M} \quad (\because R = \frac{\bar{R}}{M})$$

$$\Rightarrow PV = n\bar{R}T \quad (\because n = \frac{m}{M})$$

By equation $PV = n\bar{R}T$

$$= P_1 V_1 = n_1 \bar{R} T_1$$

$$\Rightarrow n_1 = \frac{P_1 V_1}{\bar{R} T_1} = \frac{0.1 \text{ MPa} \times 1 \text{ m}^3}{8.314 \times 300 \text{ K}}$$

$$= \frac{0.1 \times 10^3 \text{ kPa} \times 1 \text{ m}^3}{8.314 \times 300}$$

$$\Rightarrow n_1 = 0.040 \text{ moles}$$

$$\text{For } n_2 = \frac{P_2 V_2}{\bar{R} T_2} = \frac{1 \times 10^3 \times 2}{8.314 \times 1000}$$

$$= 0.24 \text{ Moles}$$

$$n_f = n_1 + n_2 = 0.04 + 0.24 = 0.28 \text{ Moles}$$

$$V_f = V_1 + V_2 = 3 \text{ m}^3$$

Here rigid & Insulated tank given

$$\Rightarrow dQ = 0, \quad dW = 0$$

$$(\because \text{Rigid} \Rightarrow V = C \Rightarrow dW = 0)$$

$$\Rightarrow \text{By 1}^{\text{st}} \text{ law}$$

$$dQ - dW = dU = C_v dT = 0$$

$$\text{Here } dU_1 + dU_2 = 0$$

$$\Rightarrow n_1 C_v dT + n_2 C_v dT = 0$$

$$\Rightarrow n_1 C_v (T_f - T_1) + n_2 C_v (T_f - T_2) = 0$$

$$0.040 C_v (T_f - 300) + 0.24 C_v (T_f - 1000) = 0$$

$$\Rightarrow C_v (0.28 T_f - 241.2) = 0$$

$$\Rightarrow T_f \approx 900 \text{ K}$$

Again

$$\Rightarrow P_f V_f = n_f \bar{R} T_f$$

$$\Rightarrow P_f = \frac{n_f \bar{R} T_f}{V_f} = \frac{0.28(8.314)(900)}{3}$$

$$= 700 \text{ kPa}$$

$$\Rightarrow P_f = 0.7 \text{ MPa}$$



08. (i) Ans: (c) , (ii) Ans: (b) , (iii) Ans: (b)

Sol:

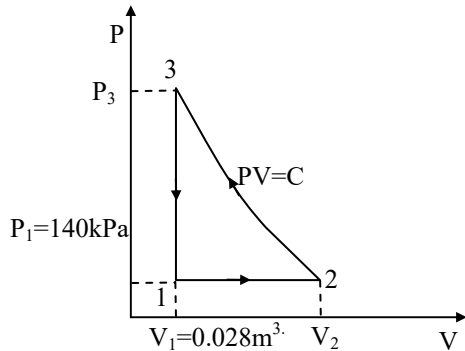

Given

Process 1 → 2: (P = C),

$$P_1 = 1.4 \text{ bar,}$$

$$V_1 = 0.028 \text{ m}^3,$$

$$W_{1-2} = 10.5 \text{ kJ}$$

Process 2 – 3: (PV = C),

$$U_3 = U_2$$

Process 3 – 1: (V = C),

$$U_1 - U_3 = -26.4 \text{ kJ}$$

Process 1 – 2: (Constant pressure)

$$\Rightarrow Q_{1-2} - W_{1-2} = U_{1-2}$$

$$\text{Given } {}_1W_2 = 10.5 \text{ kJ} = P(V_2 - V_1)$$

$$W_{1-2} = P_1 (V_2 - V_1)$$

$$\Rightarrow 10.5 = 140(V_2 - 0.028)$$

$$\Rightarrow V_2 = 0.103 \text{ m}^3$$

$$U_3 = U_2 \text{ \& } U_1 - U_3 = -26.4 \text{ kJ}$$

$$\Rightarrow U_1 - U_2 = -26.4 \text{ kJ}$$

$$\Rightarrow U_2 - U_1 = 26.4 \text{ kJ.}$$

$$\Rightarrow {}_1Q_2 = {}_1U_2 + {}_1W_2$$

$$\Rightarrow {}_1Q_2 = 26.4 + 10.5$$

$$\Rightarrow {}_1Q_2 = 36.9 \text{ kJ}$$

Process 2 – 3: (Isothermal Process)

$$\Rightarrow Q_{2-3} - W_{2-3} = U_{2-3}$$

$$\text{Hence } T = C \Rightarrow {}_2U_3 = 0$$

$$\begin{aligned} \Rightarrow Q_{2-3} &= W_{2-3} = P_2 V_2 \ln \frac{V_3}{V_2} \\ &= 140 \times 0.103 \ln \left(\frac{0.028}{0.103} \right) \end{aligned}$$

$$\Rightarrow {}_2W_3 = -18.79 \text{ kJ}$$

Process 3 – 1: (constant volume)

$${}_3W_1 = 0$$

$$\Rightarrow dQ - dW = dU$$

$$\Rightarrow {}_3Q_1 = {}_3U_1 = -26.4$$

$$\Rightarrow {}_3Q_1 = -26.4 \text{ kJ}$$

For checking answer

$$\Sigma Q = {}_1Q_2 + {}_2Q_3 + {}_3Q_1$$

$$\Sigma Q = -8.28 \text{ kJ}$$

$$\Sigma W = {}_1W_2 + {}_2W_3 + {}_3W_1$$

$$\Rightarrow \Sigma W = -8.28 \text{ kJ}$$

$$\Rightarrow \Sigma Q = \Sigma W \text{ (First law proved)}$$

09. Ans: 74 kJ, 22 kJ

Sol:

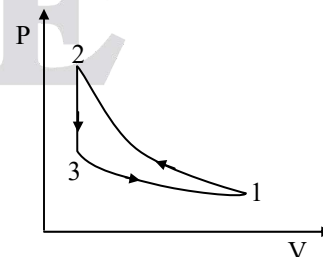

$$U_1 = 512 \text{ kJ, } P_1 = 1 \text{ bar, } P_2 = 2 \text{ bar}$$

$$U_2 = 690 \text{ kJ, } V_1 = 1.5 \text{ m}^3$$

Process 1-2:



$$\begin{aligned}\delta Q_{1-2} &= dU + \delta W_{1-2} \\ &= U_2 - U_1 + P_1 V_1 \ln\left(\frac{V_2}{V_1}\right) \\ &= 690 - 512 + 100 \times 1.5 \ln\left(\frac{P_1}{P_2}\right) \\ &= 178 + 150 \ln\left(\frac{1}{2}\right)\end{aligned}$$

$$\delta Q_{1-2} = 74.02 \text{ kJ}$$

Process 2-3 :

$$\begin{aligned}\delta Q &= dU + \delta W \\ -150 &= U_3 - U_2 \\ -150 &= U_3 - 690 \\ U_3 &= 540 \text{ kJ}\end{aligned}$$

Process 3-1 :

$$\begin{aligned}\delta Q &= dU + \delta W \\ &= U_1 - U_3 + 50 \\ &= 512 - 540 + 50 \\ Q_{3-1} &= 22 \text{ kJ}\end{aligned}$$

10. Ans: 69.3 kJ, 131.831 kJ

Sol:

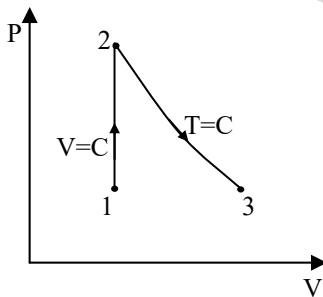

Air :

$$\begin{aligned}P_1 &= 100 \text{ kPa} \\ T_1 &= 300 \text{ K} \\ V_1 &= 0.75 \text{ m}^3 \\ T_2 &= 400 \text{ K}\end{aligned}$$

1 - 2 Process $V = C$

$$\frac{P_1}{T_1} = \frac{P_2}{T_2}$$

$$P_2 = \frac{T_2}{T_1} \times P_1 = \frac{400}{300} \times 100 = 133.33 \text{ kPa}$$

$$T_3 = 400 \text{ K} = T_2$$

$$V_3 = 1.5 \text{ m}^3$$

$${}_1W_2 = 0 (\because V = C)$$

$$m = \frac{P_1 V_1}{RT_1} = \frac{100 \times 0.75}{0.287 \times 300} = 0.871 \text{ kg}$$

$$\begin{aligned}{}_1Q_2 &= mc_v(T_2 - T_1) \\ &= 0.871 \times 0.718 (400 - 300) = 62.54 \text{ kJ}\end{aligned}$$

2 - 3 Process $T = C$

$$P_2 V_2 = P_3 V_3$$

$$P_3 = P_2 \times \frac{V_2}{V_3} = 133.33 \times \frac{0.75}{1.5} = 66.67 \text{ kPa}$$

$${}_2W_3 = {}_2Q_3 = P_2 V_2 \ln \frac{V_3}{V_2}$$

$$= 133.33 \times 0.75 \ln \frac{1.5}{0.75} = 69.313 \text{ kJ}$$

$${}_1W_3 = {}_1W_2 + {}_2W_3 = 0 + 69.313 = 69.313 \text{ kJ}$$

$${}_1Q_3 = {}_1Q_2 + {}_2Q_3$$

$$= 62.54 + 69.313 = 131.853 \text{ kJ}$$

11. Ans: 516 kJ, 2454.6 kJ

Sol: $m_{\text{air}} = 3 \text{ kg}$, $P_1 = 200 \text{ kPa}$,

$T_1 = 27^\circ\text{C} = 300 \text{ K}$, $P_2 = 400 \text{ kPa}$

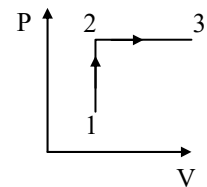
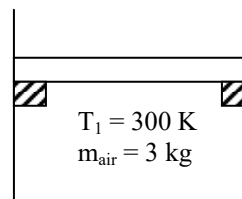



1 - 2 (V = C)

$$\frac{200}{300} = \frac{400}{T_2}$$

$$T_2 = 600 \text{ K}$$

$$P_1 V_1 = mRT_1$$

$$V_1 = \frac{3 \times 0.287 \times 300}{200} = 1.2915 \text{ m}^3$$

$$V_1 = V_2 = 1.2915 \text{ m}^3,$$

$$V_3 = 2V_2 = 2.583 \text{ m}^3$$

2 - 3 (P = C)

$$\frac{V_3}{V_2} = \frac{T_3}{T_2}$$

$$2 = \frac{T_3}{600}$$

$$T_3 = 1200 \text{ K}$$

$$\text{Work done} = 0 + P \times (V_3 - V_2)$$

$$= 400 \times 1.2915 = 516.6 \text{ kJ}$$

$${}_1Q_2 = m c_v (T_2 - T_1)$$

$$= 3 \times 0.717 \times (600 - 30)$$

$$= 645.3 \text{ kJ}$$

$${}_2Q_3 = {}_2W_3 + {}_2U_3 = m c_p (T_3 - T_2)$$

$$= 3 \times 1.005 (1200 - 600)$$

$$= 1809 \text{ kJ}$$

$$\text{Total heat transfer} = 645.3 + 1809 = 2454.3$$

12. (i) Ans: (d) , (ii) Ans: (a) , (iii) Ans: (d)

Sol:

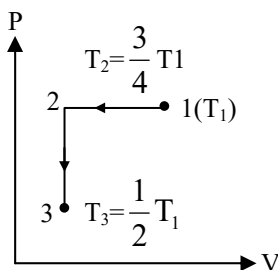

Process 1 - 2: (P = C)

$$\frac{V_1}{T_1} = \frac{V_2}{T_2}$$

$$\therefore \frac{V_2}{V_1} = \frac{T_2}{T_1} = \frac{\frac{3}{4} T_1}{T_1} = \frac{3}{4} = 0.75$$

$${}_1Q_2 - {}_1W_2 = {}_1U_2$$

$${}_1Q_2 - P(V_2 - V_1) = (U_2 - U_1)$$

$$\therefore {}_1Q_2 = C_v(T_2 - T_1) + P(V_2 - V_1)$$

$$= C_v T_1 \left(\frac{T_2}{T_1} - 1 \right) + P V_1 \left(\frac{V_2}{V_1} - 1 \right)$$

$$= C_v T_1 \left(\frac{3}{4} - 1 \right) + P V_1 \left(\frac{3}{4} - 1 \right)$$

$$= -\frac{1}{4} (C_v T_1 + P V_1)$$

$$= -\frac{1}{4} (C_v T_1 + R T_1)$$

$$= -\frac{1}{4} T_1 (R + C_v) = -\frac{1}{4} T_1 C_p = -\frac{C_p T_1}{4}$$

Process 1 - 2:

$${}_1W_2 = P(V_2 - V_1)$$

$$= P V_1 \left(\frac{V_2}{V_1} - 1 \right) = \frac{-R T_1}{4}$$

Process 2 - 3: (V = Constant)

$${}_2W_3 = 0$$

$${}_2Q_3 = {}_2U_3 = U_3 - U_2$$

$$= C_v (T_3 - T_2)$$

$$= C_v \left(\frac{T_1}{2} - \frac{3T_1}{4} \right)$$

$$= -C_v T_1 \left(\frac{1}{4} \right)$$



$$= \frac{-C_v T_1}{4}$$

$${}_1Q_3 = {}_1Q_2 + {}_2Q_3$$

$$= \frac{-C_p T_1}{4} + \frac{-C_v T_1}{4}$$

$$= \frac{-T_1}{4} (C_p + C_v) = (C_v + C_p) \frac{T_1}{4}$$

13. (i) Ans: (c), (ii) Ans: (c), (iii) Ans: (b)

Sol:

$$m = 1.5 \text{ kg}$$

$$P_1 = 1000 \text{ kPa}$$

$$P_2 = 200 \text{ kPa}$$

$$V_1 = 0.2 \text{ m}^3$$

$$V_2 = 1.2 \text{ m}^3$$

$$P = a + bV$$

$$u = 1.5Pv - 85$$

$$1000 = a + 0.2b \dots\dots\dots \text{(i)}$$

$$200 = a + 1.2b \dots\dots\dots \text{(ii)}$$

By solving

$$b = -800$$

$$a = 1160$$

$$P = 1160 - 800V$$

$$\text{(ii) } {}_1W_2 = \int_{V_1}^{V_2} PdV = \int_{V_1}^{V_2} (1160 - 800V)dV$$

$$= \int_{0.2}^{1.2} (1160 - 800V)dV$$

$$= 1160(1.2 - 0.2) - 400(1.2^2 - 0.2^2)$$

$$= 600 \text{ kJ}$$

$$\text{(iii) } u = (1.5 Pv - 85) \text{ kJ/kg}$$

$$= (1.5P \frac{V}{m} - 85) \text{ kJ/kg}$$

$$= 1.5P \frac{V}{m} - 85$$

$$= 1.5P \frac{V}{1.5} - 85$$

$$= (Pv - 85) \text{ kJ/kg}$$

$$u_1 = P_1 V_1 - 85 = 1000 \times 0.2 - 85 = 115 \text{ kJ/kg}$$

$$u_2 = P_2 V_2 - 85 = 200 \times 1.2 - 85 = 155 \text{ kJ/kg}$$

$$u_2 - u_1 = 40 \text{ kJ/kg}$$

$$dU = m(u_2 - u_1) = 1.5 \times 40 = 60 \text{ kJ}$$

$$dQ - dW = dU$$

$$dQ = 60 + 600 = 660 \text{ kJ}$$

$$u = Pv - 85$$

$$= (a + bV)v - 85$$

$$= av + bV^2 - 85 = f(v)$$

For Maximum internal energy

$$\frac{du}{dv} = 0$$

$$\Rightarrow a + 2bV = 0$$

$$\Rightarrow V = \frac{-a}{2b} = \frac{-1160}{-2 \times 800} \text{ m}^3 = 0.725 \text{ m}^3$$

$$u_{\max} = (1160 \times 0.725) - (800 \times 0.725^2) - 85 = 335.5 \text{ kJ/kg}$$

$$U_{\max} = \dot{m} \times u_{\max} = 1.5 \times 335.5$$

$$= 503.25 \text{ kJ}$$



14. Ans: (a)

Sol: $n = 1$ mole

$$C_V = 20.785 \text{ J/mol K}$$

$$T_1 = 300 \text{ K}$$

$$P = 50 \text{ W}$$

$$t = 120 \text{ sec}$$

$dQ = 0$ (Insulated non flow process)

$$dQ - dW = dU$$

$$0 - (-P \times t) = nC_V dT$$

$$50 \times 120 = 1 \times 20.785 \times (T_2 - 300)$$

$$T_2 = 588 \text{ K}$$

$$\text{For Ideal gas, } \frac{P_1 V_1}{T_1} = \frac{P_2 V_2}{T_2}$$

$$\therefore P_2 = \frac{T_2}{T_1} \times \frac{V_1}{V_2} \times P_1$$

$$= \frac{588}{300} \times 100$$

$$P_2 = 196 \text{ kPa} = 0.196 \text{ MPa}$$

15. Ans: (b)

Sol:

For process 1 – 2 : (P = C)

$$\Rightarrow {}_1W_2 = P_1(V_2 - V_1)$$

$$\Rightarrow {}_1W_2 = 100 \times (0.3 - 0.003)$$

$$\Rightarrow {}_1W_2 = 29.7 \text{ kJ}$$

By Ist law

$${}_1Q_2 - {}_1W_2 = E_2 - E_1$$

$$\Rightarrow 0 - 29.7 = E_2 - E_1$$

$$(\because {}_1Q_2 = 0)$$

$$-29.7 = E_2 - 0$$

$$E_2 = -29.7 \text{ kJ}$$

By Process 2 – 3

$${}_2Q_3 - {}_2W_3 = {}_2E_3 = E_3 - E_2$$

$${}_2Q_3 - P(V_3 - V_2) = E_3 - E_2$$

$$-105 - 100(0.06 - 0.3) = E_3 - (-29.7)$$

$$E_3 = -110.7 \text{ kJ}$$

16. (i) Ans: (a) , (ii) Ans: (b)

$$\text{Sol: } C_p = 2.093 + \frac{41.87}{t + 100} \text{ J/}^\circ\text{C}$$

$$P = 1 \text{ atm}$$

$$V_1 = 2000 \text{ cm}^3 \quad T_1 = 0^\circ\text{C}$$

$$V_2 = 2400 \text{ cm}^3 \quad T_2 = 100^\circ\text{C}$$

Here $C_p = \text{J/}^\circ\text{C}$ form it should always in $\text{J/kg }^\circ\text{C}$ form

$$\text{So } C_p \times \text{kg} = \text{J/}^\circ\text{C}$$

$$\Rightarrow \text{Sp. Heat} \times \text{mass} = \text{Heat capacity}$$

$$dQ = \int_{T_1}^{T_2} C_p dt = \int_{0^\circ\text{C}}^{100^\circ\text{C}} \left[2.093 + \frac{41.87}{t + 100} \right] dt$$

$$= [2.093t]_0^{100} + 41.87 \ln[t + 100]_0^{100}$$

$$= [2.093(100)] + [41.87 \ln(200) - 41.87 \ln(100)]$$

$$= 209.3 + [2218 - 192.81]$$

(i) $dQ = 238.32 \text{ J}$

Here constant pressure is given

$$\Rightarrow {}_1W_2 = P_1(V_2 - V_1) = P_{\text{atm}}(V_2 - V_1)$$

$$= 101325(2400 - 2000) \times 10^{-6}$$

$${}_1W_2 = 40.53 \text{ J}$$

$$\Rightarrow dQ - dW = dU$$

$$\Rightarrow dU = 238.32 - 40.53$$

$$dU = 197.79 \text{ J}$$



17. (i) Ans: (a), (ii) Ans: (b), (iii) Ans: (a)

Sol: $h_1 = 3000 \text{ kJ/kg}$, $h_2 = 2762 \text{ kJ/kg}$

$V_1 = 60 \text{ m/s}$, $V_2 = ?$

$A_1 = 0.1 \text{ m}^2$,

$v_2 = 0.498 \text{ m}^3/\text{kg}$

$v_1 = 0.187 \text{ m}^3/\text{kg}$

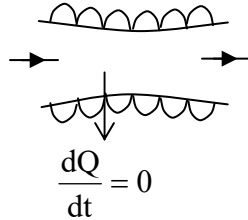

Applying steady flow energy equation

$$h_1 + \frac{V_1^2}{2000} + \frac{dQ}{dt} = h_2 + \frac{V_2^2}{2000} + \frac{dW}{dt}$$

$$\Rightarrow 3000 + \frac{(60)^2}{2000} = (2762) + \frac{V_2^2}{2000}$$

$$\Rightarrow V_2 = 692.5 \text{ m./s}$$

$$\Rightarrow \dot{m} = \frac{A_1 V_1}{v_1} = \frac{A_2 V_2}{v_2}$$

$$\Rightarrow \dot{m} = \frac{(0.1)(60)}{0.187} \Rightarrow \dot{m} = 32.08 \frac{\text{kg}}{\text{sec}}$$

Find, $A_2 = ?$

$$\Rightarrow \dot{m} = \frac{A_2 V_2}{v_2} \Rightarrow A_2 = \frac{\dot{m} v_2}{V_2}$$

$$\Rightarrow A_2 = \frac{32.08 \times (0.498)}{692.5}$$

$$\Rightarrow A_2 = 0.023 \text{ m}^2$$

18. Ans: (a)

Sol: Given:

$P_1 = 1.2 \text{ MPa}$, $P_2 = 20 \text{ kPa}$, $T_1 = 188^\circ\text{C}$,

$h_1 = 2785 \text{ kJ/kg}$, $h_2 = 2512 \text{ kJ/kg}$

$V_1 = 33.33 \text{ m/s}$, $V_2 = 100 \text{ m/sec}$.

$Z_2 = 0 \text{ m}$, $Z_1 = 3 \text{ m}$,

$\dot{m} = 0.42 \text{ kg/sec}$

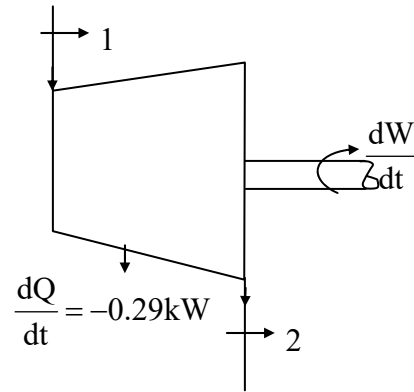

Applying steady flow energy equations

$$\dot{m} \left[h_1 + \frac{Z_1 g}{1000} + \frac{V_1^2}{2000} \right] + \frac{dQ}{dt}$$

$$= \dot{m} \left[h_2 + \frac{V_2^2}{2000} + \frac{Z_2 g}{1000} \right] + \frac{dW}{dt}$$

$$\Rightarrow 0.42 \left[2785 + \frac{3(9.81)}{1000} + \frac{(33.33)^2}{2000} \right] - 0.29$$

$$= 0.42 \left[2512 + \frac{(100)^2}{2000} + 0 \right] + \frac{dW}{dt}$$

$$\Rightarrow \frac{dW}{dt} = 112.51 \text{ kW}$$

19. Ans: (a)

Sol:

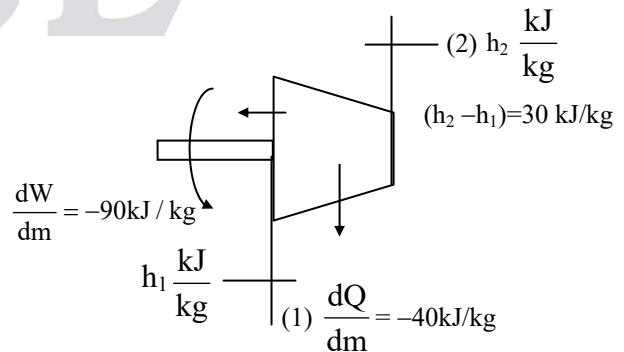



$$dW = -90 \text{ kN.m/kg} = -90 \text{ kJ/kg}$$

$$(h_2 - h_1) = 30 \text{ kJ/kg.}$$

$$\frac{dQ}{dm} = -40 \text{ kJ/kg}$$

Heat rejected $\Rightarrow dQ = -Ve'$

According to Steady flow energy equation,

$$h_1 + \left(\frac{dQ}{dm}\right)_{\text{air}} + \left(\frac{dQ}{dm}\right)_{\text{w}} = h_2 + \left(\frac{dW}{dm}\right)$$

$$\begin{aligned} \left(\frac{dQ}{dm}\right)_{\text{air}} &= (h_2 - h_1) + \frac{dW}{dm} - \left(\frac{dQ}{dm}\right)_{\text{w}} \\ &= 30 - 90 - (-40) \\ &= -20 \text{ kJ} \end{aligned}$$

(-ve sign indicates heat is rejected from the system)

20. Ans: (b)

Sol:

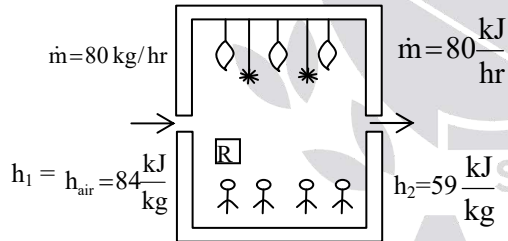

$$\left(\frac{dW}{dt}\right)_{\text{fans}} = 0.18 \times 2 = -0.36 \text{ kW}$$

$$\left(\frac{dW}{dt}\right)_{\text{Bulb}} = 3 \times 0.1 = -0.3 \text{ kW}$$

$$\left(\frac{dW}{dt}\right)_{\text{Total}} = -0.36 + (-0.3) = -0.66 \text{ kW}$$

$$\dot{m}_{\text{air enter}} = 80 \text{ kg/hr.}$$

$$h_1 = 84 \text{ kJ/kg}$$

$$h_2 = 59 \text{ kJ/kg}$$

$$\left(\frac{dQ}{dt}\right)_{\text{person}} = 630 \times 4 = 2520 \text{ kJ/hr}$$

$$\left(\frac{dQ}{dT}\right)_{\text{R cooler}} = ?$$

By steady flow energy equation

$$\begin{aligned} \dot{m}_1 h_1 + \left(\frac{dQ}{dt}\right)_{\text{person}} + \left(\frac{dQ}{dt}\right)_{\text{RCooler}} \\ = \dot{m}_2 h_2 + \left(\frac{dW}{dt}\right)_{\text{fan}} + \left(\frac{dW}{dt}\right)_{\text{bulb}} \end{aligned}$$

$$\begin{aligned} \frac{80 \times 84}{3600} + \frac{2520}{3600} + \left(\frac{dQ}{dt}\right)_{\text{RCooler}} \\ = \frac{80 \times 59}{3600} + (-0.66) \end{aligned}$$

$$\Rightarrow \left(\frac{dQ}{dt}\right)_{\text{RC}} = -1.91 \text{ kW}$$

Heat is removed from a cooler is 1.91 kW

21. (i) Ans: (a), (ii) Ans: (a)

$$\text{Sol: } \dot{m}_1 = 0.01 \text{ kg/sec} \quad h_1 = 2952 \text{ kJ/kg}$$

$$\dot{m}_2 = 0.1 \text{ kg/sec} \quad h_2 = 2569 \text{ kJ/kg.K}$$

$$\dot{m}_3 = 0.001 \text{ kg/sec} \quad h_3 = 420 \text{ kJ/kg}$$

$$V_1 = 20 \text{ m/sec} \quad V_2 = 120 \text{ m/sec}$$

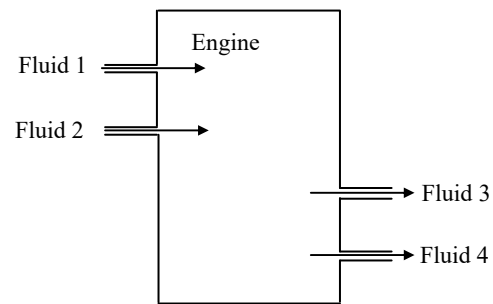



1) Mass balance

Mass entering/sec = mass leaving/sec

$$\dot{m}_1 + \dot{m}_2 = \dot{m}_3 + \dot{m}_4$$

$$\Rightarrow \dot{m}_4 = 0.109 \text{ kg/sec}$$

(2) Energy balance

$$\dot{m}_1 \left[h_1 + \frac{V_1^2}{2000} \right] + \dot{m}_2 \left[h_2 + \frac{V_2^2}{2000} \right] + \frac{dQ}{dt}$$

$$= \dot{m}_3 h_3 + \dot{m}_4 h_4 + \frac{dW}{dt}$$

Here $\frac{dQ}{dt} = 0$

$$0.01 \left[2952 + \frac{(20)^2}{2000} \right] + 0.1 \left[2569 + \frac{(120)^2}{2000} \right]$$

$$= (0.001 \times 420) + (0.109 \times h_4) + 25$$

$$\Rightarrow h_4 = 2401 \text{ kJ/kg}$$

22. Ans: (c)

Sol:

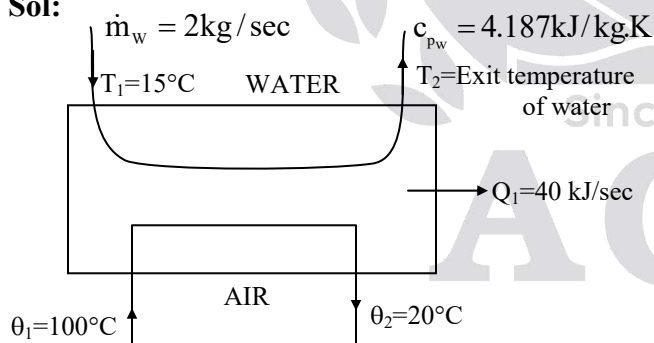

$$\dot{m}_a = 3 \text{ kg/sec}$$

$$c_{pa} = 1.005 \text{ kJ/kg.K}$$

Heat lost to surrounding = $Q_1 = 40 \text{ kW}$

Heat lost by air = Heat gained by water +
heat lost to surroundings

$$\dot{m}_a c_{pa} (\theta_1 - \theta_2) = \dot{m}_w c_{pw} (T_2 - T_1) + 40$$

$$3 \times 1.005 [100 - 20] = 2 \times 4.187 (T_2 - 15) + 40$$

$$T_2 = 15 + \frac{241.2 - 40}{2 \times 4.187} = 39.02^\circ\text{C}$$

23. Ans: (d)

Sol:

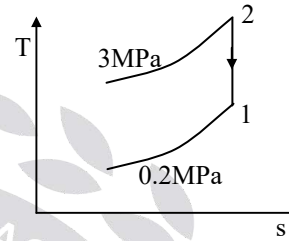

$$T_1 = 1023 \text{ K}$$

Argon is a monoatomic gas, $\gamma_{Ar} = \frac{5}{3}$

Molecular weight of Argon, $M = 40$

$$C_{p_{Ar}} = \frac{\gamma \bar{R}}{M(\gamma - 1)}$$

$$= \frac{\frac{5}{3} \times (8.314)}{40 \times \left(\frac{5}{3} - 1 \right)} = 0.5196 \text{ kJ/kg.K}$$

$$T_2 = T_1 \left(\frac{P_2}{P_1} \right)^{\frac{\gamma-1}{\gamma}} = 1023 \left(\frac{0.2}{3} \right)^{0.4}$$

$$= 346.28 \text{ K} = 73.28^\circ\text{C}$$

$$\text{Power (kW)} = \dot{m} C_{p_{Ar}} (T_1 - T_2)$$

$$= 5 \times 0.5196 \times (1023 - 346.28)$$

$$= \frac{1758.1}{1000} = 1.758 \text{ MW}$$



24. Ans: (b)

Sol: 'He' is monoatomic gas, $\gamma = \frac{5}{3}$, $M = 4$,

$$(C_p)_{Ar} = \frac{\gamma \bar{R}}{M(\gamma - 1)} = \frac{\frac{5}{3} \times (8.314)}{40 \times \left(\frac{5}{3} - 1\right)} = 0.5196 \text{ kJ/kgK}$$

$$(C_p)_{He} = \frac{\gamma \bar{R}}{M(\gamma - 1)} = \frac{\frac{5}{3} \times (8.314)}{4 \times \left(\frac{5}{3} - 1\right)} = 5.196 \text{ kJ/kgK}$$

$$\gamma_{\text{mixture}} = \frac{5}{3}$$

$$C_{p \text{ mix}} = 0.5(C_p)_{He} + 0.5(C_p)_{Ar} \\ = 0.5 \times 0.519 + 0.5 \times 5.19 = 2.857 \text{ kJ/kg.K}$$

$$T_2 = T_1 \left(\frac{P_2}{P_1} \right)^{\frac{\gamma-1}{\gamma}} \\ = 1200 \left(\frac{100}{1000} \right)^{0.4} = 477.72 \text{ K}$$

$$\text{Power (kW)} = \dot{m}_a \times C_{p \text{ mix}} \times (T_1 - T_2) \\ = 0.3 \times 2.857 \times (1200 - 477.72) \\ = 619.05 \text{ kW}$$

25. Ans: (a)

Sol: $V_c = V_1 = 15 \text{ cm}^3$

$$V_{CO} = V_2 = 1500 \text{ cm}^3$$

$$P_1 = P_{He} = 20 \text{ atm}$$

$$T_1 = 40^\circ\text{C}$$

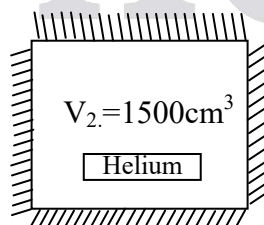

$\Rightarrow dW = 0$ (Free expansion)

$dQ = 0$ (due to insulation)

By 1st law $dU = dQ - dW$

$$\Rightarrow dU = 0 = C_v dT = 0$$

$$\Rightarrow dT = 0 \Rightarrow T = \text{constant}$$

Temperature = constant (Isothermal)

$$\Rightarrow P_1 V_1 = P_2 V_2$$

$$\Rightarrow 20 \times 15 = P_2 \times 1500$$

$$\Rightarrow P_2 = 0.2 \text{ atm}$$

26.

Sol:

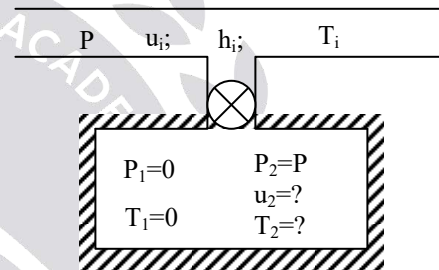

Insulated $Q = 0$

Evacuated $m_1 = 0$

$$Q = m_2 u_2 - m_1 u_1 - (m_2 - m_1) h$$

$$m_2 u_2 = m_2 h_i$$

Final internal energy = $u_2 = h_i$

$$c_v T_2 = c_p T_i$$

$$\text{Final temperature} = T_2 = \frac{c_p}{c_v} T_i = \gamma T_i$$



Chapter- 4
Second Law of Thermodynamics

01. Ans: (b)

02. Ans: (c)

Sol: Given: H.E

$$\eta_{H.E} = \frac{T_1 - T_2}{T_1} = \frac{Q_1 - Q_2}{Q_1}$$

$$\Rightarrow \frac{1200 - 300}{1200} = \frac{40 - Q_2}{40}$$

$$\Rightarrow Q_2 = 10 \text{ kW}$$

03. Ans: (c)

Sol: Given: Electric power generating station means H.E

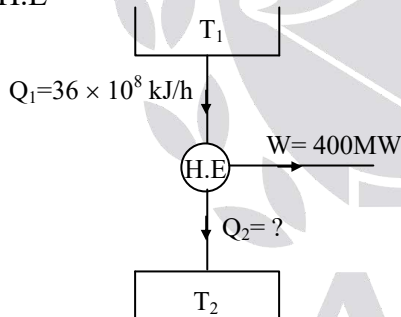

$$\eta_{H.E} = \frac{Q_1 - Q_2}{Q_1} = \frac{W}{Q_1}$$

$$\Rightarrow Q_2 = Q_1 - W$$

$$Q_2 = 36 \times 10^8 \frac{\text{KJ}}{\text{h}} - 400 \text{ MW}$$

$$= \frac{36 \times 10^8}{1000 \times 3600} (\text{MW}) - 400 \text{ MW}$$

$$= 1000 \text{ MW} - 400 \text{ MW}$$

$$Q_2 = 600 \text{ MW}$$

04. Ans: (b)

Sol:

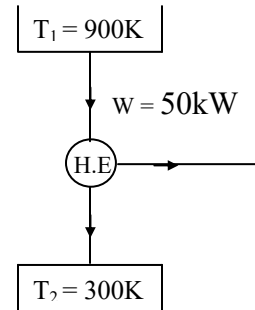

$$\eta = \frac{\text{Power (kW)}}{Q_s (\text{kW})} = \frac{W (\text{kW})}{\dot{m}_f \left(\frac{\text{kg}}{\text{sec}} \right) \times C.V \left(\frac{\text{kJ}}{\text{kg}} \right)}$$

$$= \frac{50}{\frac{3}{3600} \times 75000} = 0.8$$

$$\eta_c = \frac{T_1 - T_2}{T_1} = \frac{627 - 27}{900} = 0.67$$

$\eta > \eta_c \Rightarrow$ Not possible

05. Ans: (b)

$$\text{Sol: } (\text{COP})_R = \frac{1 - \eta_E}{\eta_E} = \frac{1 - 0.75}{0.75} = 0.33$$

06. Ans: (a)

Sol: Assertion is true

Reason is true and reason is the correct explanation.

07. Ans: (a)

Sol: PMM I \rightarrow A machine which can supply mechanical work continuously without consumption of any energy. So, statement (2) is wrong.



After eliminating statement (2) only one option is available i.e., option (a).

08. Ans: (c)

Sol: ${}_1Q_2 = {}_1W_2 + {}_1U_2$

$$= \frac{P_1V_1 - P_2V_2}{n-1} + C_v[T_2 - T_1]$$

$$= \frac{R}{n-1}[T_1 - T_2] + \frac{R}{\gamma-1}[T_2 - T_1]$$

$$= \frac{R}{n-1}[T_1 - T_2] - \frac{R}{\gamma-1}[T_1 - T_2]$$

$$= R[T_1 - T_2] \left[\frac{1}{n-1} - \frac{1}{\gamma-1} \right]$$

$$= R[T_1 - T_2] \left[\frac{(\gamma-1) - (n-1)}{(n-1)(\gamma-1)} \right]$$

$$= \frac{\gamma-n}{(n-1)(\gamma-1)} [R(T_1 - T_2)]$$

$$= \frac{(\gamma-n)}{(\gamma-1)} \times \frac{R(T_1 - T_2)}{(n-1)}$$

$$= \left(\frac{\gamma-n}{\gamma-1} \right) (W)$$

= Heat transfer for polytropic process

09. Ans: (d)

Sol: $\eta_1 = \frac{W}{Q_1} = \frac{8.2}{\left(\frac{1500}{60}\right)} = 0.328$

$$\eta_2 = \frac{W}{Q_2} = \frac{8.75}{\left(\frac{1600}{60}\right)} = 0.328$$

$$\eta_3 = \frac{W}{Q_3} = \frac{9.3}{\left(\frac{1700}{60}\right)} = 0.328$$

$$\eta_4 = \frac{W}{Q_4} = \frac{9.85}{\left(\frac{1800}{60}\right)} = 0.328$$

$$\eta = \frac{W}{Q_1} \Rightarrow W = \eta \times Q_1$$

$$W = 0.328 \times \frac{2000}{60} \text{ (kJ/sec)} = 10.94 \text{ kJ/sec}$$

10. Ans: (a)

Sol: $\text{COP} = \frac{\text{NRE(kW)}}{W_C \text{ (kW)}}$

$$3.1 = \frac{10}{3600} \times \frac{4.187 \times 10^3 \times (23-6)}{W_C}$$

$$W_C = 197 \text{ W}$$

11. Ans: (a)

Sol: $\text{COP} = 3.2$, $m = 1200 \text{ kg}$, $P = 5 \text{ kW}$

$$\text{COP} = \frac{\text{NRE(kW)}}{W_C \text{ (kW)}}$$

$$= \frac{m_a \times C_{va} \times (\Delta T)_a}{W_C \text{ (kJ)}}$$

$$\Rightarrow 3.2 = \frac{1200(0.718)(22-7)}{W_C}$$

$$W_C = 4169 \text{ kJ}$$

$$\Rightarrow \text{Time} = \frac{W_C \text{ (kJ)}}{W_C \text{ (kW)}}$$

$$= \frac{4169 \text{ (kJ)}}{5 \text{ (kJ/sec)}} = \frac{834}{60} = 13.5 \text{ min}$$



12. Ans: (d)

$$\text{Sol: COP} = \frac{\text{NRE}}{W_c} = \frac{\text{NRE}}{680 \text{ kWhr}} = \frac{\text{NRE}}{680 \times 3600}$$

$$\Rightarrow \text{NRE} = 680 \times 3600 \times 1.4 = 3427 \text{ MJ/yr}$$

13. Ans: (d)

Sol:

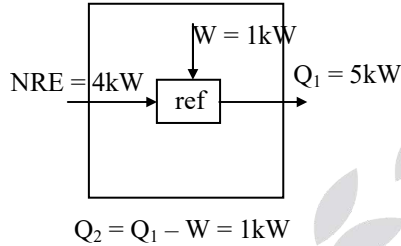

$$\text{Net effect} = Q_1 - Q_2$$

$$= 5 - 4 = 1 \text{ kW (heating)}$$

14. Ans: (d)

Sol: Given

$$\eta_E = 0.4$$

$$Q_2 + Q_4 = 3Q_1$$

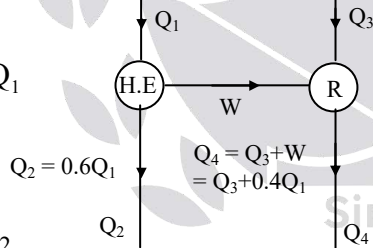

$$\eta_E = \frac{Q_1 - Q_2}{Q_1}$$

$$\Rightarrow 0.4Q_1 = Q_1 - Q_2 = W$$

$$\Rightarrow Q_2 = 0.6Q_1$$

$$Q_2 + Q_4 = 3Q_1$$

$$\Rightarrow 0.6Q_1 + Q_4 = 3Q_1$$

$$\Rightarrow Q_4 = 2.4Q_1$$

$$Q_3 = Q_4 - W = 2.4Q_1 - 0.4Q_1 = 2Q_1$$

$$(\text{COP})_R = \frac{Q_3}{W} = \frac{2Q_1}{0.4Q_1} = 5$$

15. Ans: 0.667 MJ

Sol:

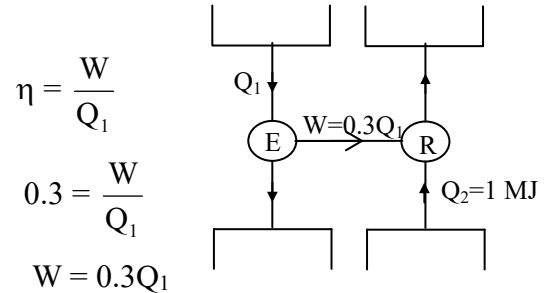

$$\eta = \frac{W}{Q_1}$$

$$0.3 = \frac{W}{Q_1}$$

$$W = 0.3Q_1$$

$$(\text{COP})_R = 5 = \frac{Q_2}{W}$$

$$\Rightarrow Q_1 = \frac{1 \text{ MJ}}{5 \times 0.3} = 0.667 \text{ MJ}$$

16. Ans: 0.68

Sol:

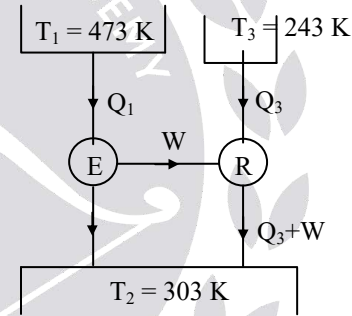

$$\eta_E = \frac{T_1 - T_2}{T_1} = \frac{W}{Q_1}$$

$$\frac{473 - 303}{473} = \frac{W}{Q_1} \Rightarrow W = 0.359Q_1$$

$$(\text{COP})_R = \frac{T_3}{T_2 - T_3} = \frac{Q_3}{W}$$

$$\frac{243}{303 - 243} = \frac{Q_3}{0.359Q_1}$$

$$\Rightarrow \frac{Q_3}{Q_1} = 1.45$$

$$\frac{Q_1}{Q_3} = 0.68$$



17. Ans: 86 kW

Sol:

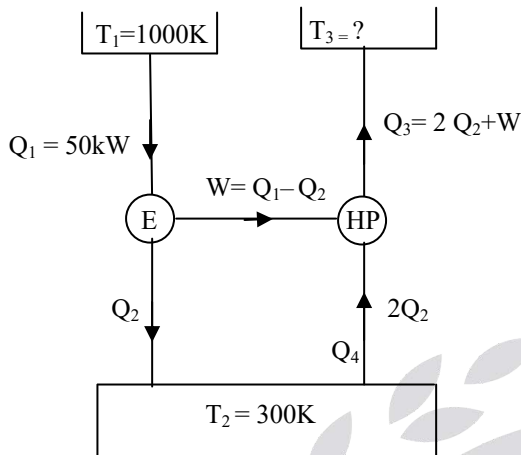

$$\eta_E = 0.4 \times \eta_{\text{Carnot}}$$

$$0.4 \times \frac{T_1 - T_2}{T_1} = \frac{W}{Q_1}$$

$$0.4 \times \frac{(1000 - 300)}{1000} = \frac{W}{Q_1}$$

$$\therefore W = 0.28Q_1$$

$$Q_2 = Q_1 - W$$

$$= Q_1 - 0.28Q_1 = 0.72Q_1$$

$$Q_2 = 0.72Q_1$$

$$Q_3 = 2Q_2 + W$$

$$= 1.44Q_1 + 0.28Q_1$$

$$Q_3 = 1.72Q_1$$

$$\frac{1.72Q_1}{0.28Q_1} = 0.5 \left(\frac{T_3}{T_3 - 300} \right)$$

$$T_3 = 326 \text{ K}$$

$$\text{If } Q_1 = 50 \text{ kW}$$

$$Q_3 = 2Q_2 + W$$

$$= 2 \times 0.72Q_1 + 0.28Q_1$$

$$= 1.72 \times 50 = 86 \text{ kW}$$

18.

Sol:

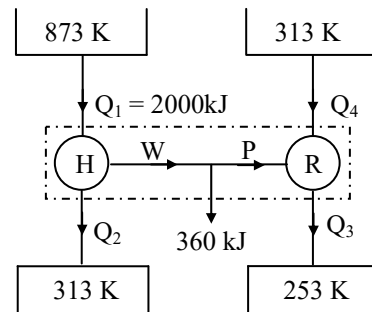

(a) Efficiency of heat engine

$$(\eta) = 1 - \frac{313}{873} = \frac{W}{2000}$$

$$W = 1283.93 \text{ kJ}$$

$$P = W - 360 = 922.932 \text{ kJ}$$

$$(\text{COP})_R = \frac{253}{313 - 253} = \frac{Q_3}{P}$$

$$Q_3 = 3891.69 \text{ kJ}$$

Energy balance :

$$Q_1 + Q_3 = Q_4 + Q_2 + 360$$

$$Q_2 + Q_4 = Q_1 + Q_3 - 360$$

$$= 2000 + 1283.93 - 360$$

$$= 5531.69 \text{ kJ}$$

(b) $\eta = 0.4 \times (\eta)_{\text{max}}$

$$= 0.4 \times \left(1 - \frac{313}{873} \right)$$

$$0.2565 = \frac{W}{2000} \Rightarrow W = 513.17 \text{ kJ}$$

$$P = W - 360 = 153.17 \text{ kJ}$$

$$(\text{COP}) = 0.4 \times (\text{COP})_{\text{max}}$$

$$= 0.4 \times \left(\frac{253}{313 - 253} \right) = \frac{Q_3}{P}$$



$$Q_3 = 1.68 \times 153.17 = 258.34 \text{ kJ}$$

$$Q_2 + Q_4 = 2000 + 258.34 - 360 \\ = 1848.34 \text{ kJ}$$

19. Ans: 15.168

Sol:

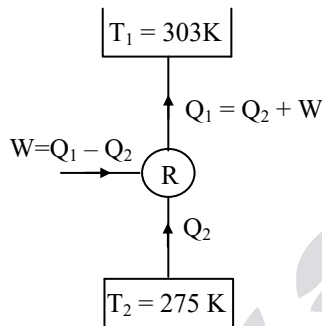

$$Q_2 = 20 \times 420 = 8400 \text{ kJ/day}$$

$$(\text{COP})_{\text{actual}} = 0.15 (\text{COP})_{\text{max}}$$

$$= 0.15 \times \frac{T_2}{T_1 - T_2} = \frac{Q_2}{W}$$

$$\Rightarrow 0.15 \times \frac{275}{303 - 275} = \frac{8400}{W}$$

$$\Rightarrow W = 5701 \text{ kJ}$$

$$1 \text{ kW hr} = 3600 \text{ kJ} = \frac{5701}{3600} = 1.58 \text{ kW hr / day}$$

Electricity bill

$$= \text{No. of unit/day} \times \text{No. of days} \times \text{cost/kWhr}$$

$$= 1.58 \times 30 \times 0.32 = 15.168/-$$

20. Ans: 6326.5 kJ/hr

Sol:

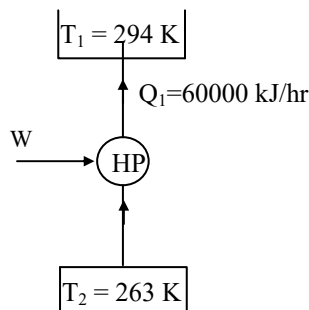

$$(\text{COP})_{\text{H.P}} = \frac{Q_1}{W} = \frac{T_1}{T_1 - T_2}$$

$$\Rightarrow \frac{60,000}{W} = \frac{294}{294 - 263}$$

$$W = 6326.5 \text{ kJ/hr}$$

$$\frac{W_{\text{HP}}}{W_{\text{EH}}} = \frac{6326.5}{60,000} = 0.1054$$

With heat pump, initial investment is high but running cost is less. With electrical heater the initial investment is less but running cost is high.

21.

Sol: (a)

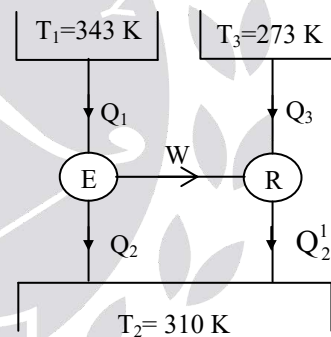

$$\dot{m} = \frac{1000}{3600} = 0.277 \text{ kg/s}$$

$$Q_3 = \dot{m} \times \text{latent heat} = 0.277 \times 333.43 \\ = 92.36 \text{ kW}$$

$$\eta_E = \frac{W}{Q_1} = \frac{T_1 - T_2}{T_1}$$

$$\therefore W = \left(\frac{343 - 310}{343} \right) Q_1$$

$$\therefore W = 0.096 Q_1 \text{ -----(1)}$$

$$(\text{COP})_R = \frac{Q_3}{W} = \frac{T_3}{T_2 - T_3}$$



$$\frac{333.43 \times 10^3}{W} = \frac{273}{310 - 273}$$

$$\therefore W = 45190.147 \text{ kJ}$$

$$\dot{W} = \frac{45190.147}{3600} = 12.55 \text{ kW}$$

From (1)

$$Q_1 = 130.759 \text{ kW}$$

$$Q_2 = Q_1 - W$$

$$Q_2 = 118.20 \text{ kW}$$

$$Q_4 = Q_3 + W = \frac{333.43 \times 10^3}{3600} + W$$

$$= 92.62 + 12.55 = 105.17 \text{ kW}$$

$$\frac{Q_3}{Q_1} = \frac{92.62}{130.75} = 0.708$$

Total heat rejected to lower temperature reservoir = $Q_2 + Q_{\text{ref}}$

$$= 118.2 + 105.17 = 223.37 \text{ kW}$$

$$\frac{\text{Energy of freezing water}}{\text{Energy of heat engine}} = \frac{92.62}{130.759} = 0.706$$

22. Ans: 2 kW, 50°C

Sol:

(a)

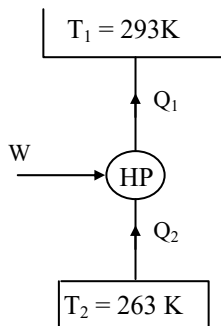

$$Q_1 = 0.65(T_1 - T_2) = 0.65(293 - 263)$$

$$= 19.5 \text{ kW}$$

$$(\text{COP})_{\text{HP}} = \frac{T_1}{T_1 - T_2} = \frac{Q_1}{W}$$

$$= \frac{293}{293 - 263} = \frac{19.5}{W}$$

$$\dot{W} = 1.99 \approx 2 \text{ kW}$$

(b)

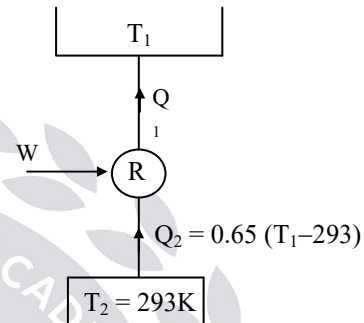

$$Q_2 = 0.65(T_1 - T_2) = 0.65(T_1 - 293)$$

$$(\text{COP})_{\text{R}} = \frac{Q_2}{W} = \frac{T_2}{T_1 - T_2}$$

$$\Rightarrow \frac{0.65(T_1 - 293)}{1.99} = \frac{293}{T_1 - 293}$$

$$T_1 = 323 \text{ K} = 50^\circ\text{C}$$

Up to 50°C outside temperature, the temperature of room can be maintained 20°C.

23.

Sol: Initial diagram:

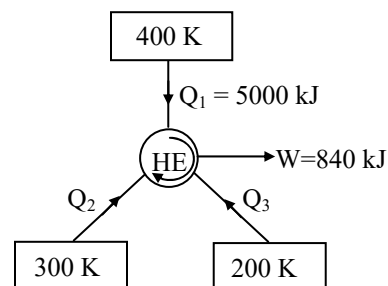



For reversible heat engine,

$$\oint \frac{dQ}{T} = 0$$

$$\frac{5000}{400} + \frac{Q_2}{300} + \frac{Q_3}{200} = 0$$

$$\Rightarrow \frac{Q_2}{300} + \frac{Q_3}{200} = -\frac{50}{4}$$

$$\frac{2Q_2 + 3Q_3}{600} = -\frac{50}{4}$$

$$2Q_2 + 3Q_3 = -\frac{50}{4} \times 600$$

$$2Q_2 + 3Q_3 = -7500 \text{ -----(i)}$$

Energy balance

$$5000 + Q_2 + Q_3 = W$$

$$Q_2 + Q_3 = 840 - 5000$$

$$Q_2 + Q_3 = -4160 \text{ ----- (ii)}$$

from eq.(i)

$$Q_2 = -4980 \text{ kJ}, Q_3 = 820 \text{ kJ}$$

Final diagram

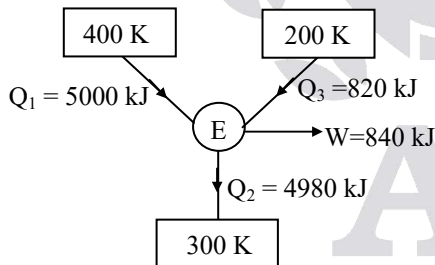

24. Ans: (d)

Sol:

For reversible engine,

$$s_{gen} = 0$$

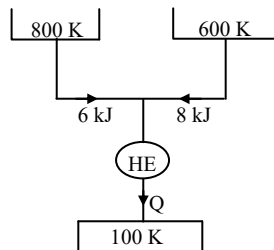

$$dS(\text{reservoir at } 800 \text{ K}) + dS(\text{reservoir at } 600\text{K}) + dS(\text{reservoir at } 100\text{K}) + dS(\text{working fluid}) = 0$$

$$-\frac{6}{800} - \frac{8}{600} + \frac{Q}{100} + 0 = 0$$

$$\Rightarrow Q = 2.083 \text{ kJ}$$

$$W_{net} = 8 + 6 - 2.083 = 11.917$$

$$\eta_{th} = \frac{11.917}{8 + 6} = 85\%$$

25.

Sol: Efficiency of Carnot heat engine :

$$\eta = 1 - \frac{T_L}{T_H}$$

$$\frac{d\eta}{dT_L} = 0 - \frac{1}{T_H} = -\frac{1}{T_H} \text{ ---- (1)}$$

$$\frac{d\eta}{dT_H} = 0 - \left(-\frac{T_L}{T_H^2} \right) = \frac{T_L}{T_H^2} \text{ ---- (2)}$$

$$\frac{d\eta}{dT_L} = -\frac{1 \times T_H}{T_H \times T_H} = -\frac{T_H}{T_H^2} \text{ ----(3)}$$

$$\frac{d\eta}{dT_H} = \frac{T_L}{T_H^2} \text{ ----(4)}$$

$\therefore T_H > T_L$, therefore, efficiency of heat engine will increase faster rate with lowering minimum temperature as compared to increasing the maximum temperature.



Chapter- 5
Entropy

01. Ans: (c)

Sol: $C_p = \left(\frac{dh}{dT} \right)_p$

$Tds = dh - vdp$

As $P = c$, $dp = 0$

So, $Tds = dh$

$C_p = \left(\frac{Tds}{dT} \right)_p$

$C_p = T \left(\frac{\partial s}{\partial T} \right)_p$

02. Ans: (b)

03. Ans: (a)

Sol:

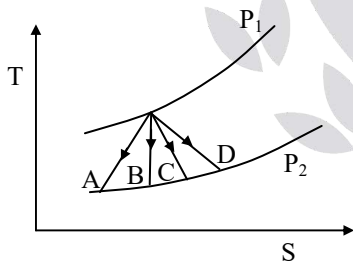

04. Ans: (b)

Sol:

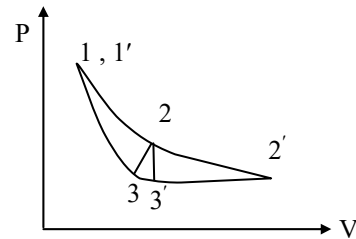
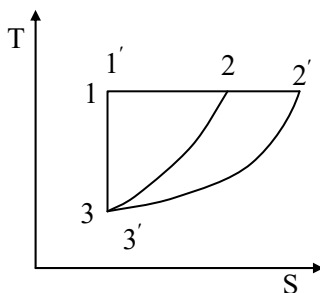

1-2, 1'-2' → constant temperature

2-3 → constant volume

2'-3' → constant pressure

3-1, 3'-1' → Entropy constant

05. Ans: (c)

06. Ans: (c)

Sol: i) Temperature measurement is due to Zeroth law of thermodynamics.

ii) Entropy is due to Second law of thermodynamics

iii) Internal Energy is due to first law of thermodynamics

07. Ans: (b)

Sol:

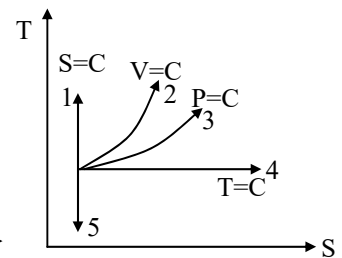
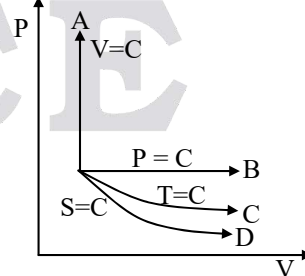

Slope of constant volume curve is more than that of constant pressure curve in T-S diagram. Similarly slope of adiabatic curve is more than that of isothermal curve in P-V diagram.



08. Ans: (c)

Sol: $(dS)_{\text{system}} = 0$

$(dS)_{\text{surr}} = 0$

$(dS)_{\text{univ}} = 0$

09. Ans: (c)

Sol: $Tds = du + Pd v$.

This process is valid for any process, reversible (or) irreversible, undergone by a closed system.

10. Ans: (c)

Sol: Area on T-S graph gives amount of heat supplied.

11. Ans: (c)

Sol:

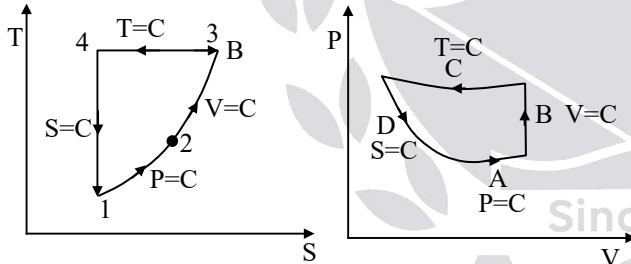

12. Ans: (b)

Sol: Clausius inequality $\oint \frac{dQ}{T} \leq 0$

$$\Rightarrow \oint \frac{dQ}{T} = \frac{Q_1}{T_1} - \frac{Q_2}{T_2} = \frac{600}{1000} - \frac{450}{300}$$

$$\oint \frac{dQ}{T} = -0.9 \text{ kJ/K} < 0$$

\Rightarrow Irreversible cycle

$$\Rightarrow \eta = \frac{Q_1 - Q_2}{Q_1} = \frac{600 - 450}{600} = 0.25 = 25\%$$

13. Ans: (d)

Sol: Find the cycle of thermodynamic.

$$T_1 = 285 + 273 = 558 \text{ K}$$

$$T_2 = 5 + 273 = 278 \text{ K}$$

$$\oint \frac{dQ}{T} = \frac{Q_1}{T_1} - \frac{Q_2}{T_2}$$

$$= \frac{1000}{558} - \frac{492}{278} = 1.79 - 1.76$$

$$\oint \frac{dQ}{T} = 0.022 > 0$$

\therefore It is an impossible cycle.

14. Ans: (c)

Sol: Motor power = 5 kW.

$$T = 20^\circ\text{C} = 293 \text{ K}$$

Due to friction, there is heat between brake and shoe and heat is transferred to surroundings.

$$(dS)_{\text{surr}} = \frac{Q}{T} = \frac{\text{Power} \times \text{Time}}{T} = \frac{5 \times 3600}{293}$$

$$dS = 61.4 \text{ kJ/K}$$

15. Ans: (c)

Sol: $S_{\text{gen}} = (S_2 - S_1) - \int \frac{dQ}{T}$

$$= \frac{Q}{T_2} - \frac{Q}{T_1} = \left(\frac{1600}{400} - \frac{1600}{800} \right)$$

$$= 2 \text{ kJ/K}$$

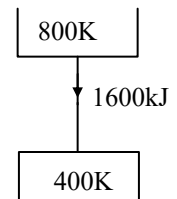



16. Ans: (b)

Sol: $m_s = 100\text{kg}$

$$(dS)_{\text{system}} = m(s_2 - s_1) = 100(0.1) = 10 \frac{\text{kJ}}{\text{K}}$$

$$(dS)_{\text{surrounding}} = (S_2 - S_1) = -5 \frac{\text{kJ}}{\text{K}}$$

$$(dS)_{\text{universe}} = (dS)_{\text{sys}} - (dS)_{\text{surr}} = 10 - 5$$

$$(dS)_{\text{uni.}} = 5 \text{ kJ/K} > 0 \Rightarrow \text{irreversible process}$$

17. Ans: (b)

Sol:

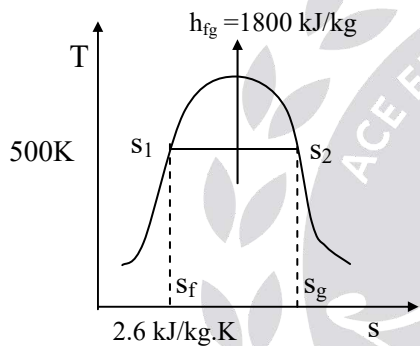

$$s_g - s_f = \frac{h_{fg}}{T_{\text{sat}}}$$

$$s_g - 2.6 = \frac{1800}{500}$$

$$s_g = 6.2 \text{ kJ/kg.K}$$

18. Ans: (b)

Sol: $T = 273 + 30 = 303 \text{ K}$

$$d\dot{Q} = -55 \times 10^6 \text{ W}$$

As heat is removed at constant temperature,

$$dS = \frac{d\dot{Q}}{T} = \frac{-55}{303} = -0.18 \text{ MW/K}$$

19. Ans: (c)

20. Ans: (c)

$$\begin{aligned} \text{Sol: } (dS)_{\text{Isothermal}} &= mR \ln \left(\frac{V_2}{V_1} \right) \\ &= mR \ln \left(\frac{P_1}{P_2} \right) \end{aligned}$$

21. Ans: (d)

22. Ans: (d)

$$\begin{aligned} \text{Sol: } Q &= \alpha T + \beta T^2 \\ dS &= \int \frac{\delta Q}{T} = \int \frac{\delta(\alpha T + \beta T^2)}{T} \\ &= \alpha \ln \frac{T_2}{T_1} + 2\beta(T_2 - T_1) \end{aligned}$$

23. Ans: (a)

$$\begin{aligned} \text{Sol: } S_{\text{gen}} &= (S_2 - S_1) - \int \frac{dQ}{T} = \frac{Q}{T_2} - \frac{Q}{T_1} \\ &= \frac{600}{278} - \frac{600}{293} = 0.11 \text{ W/K} \end{aligned}$$

24. Ans: (a)

Sol: $T_1 = 273 + 15 = 288 \text{ K}$,

$T_2 = 288.2 \text{ K}$

$$(S_2 - S_1) - \int \frac{dQ}{T} = S_{\text{gen}}$$

Here $dQ = 0$

$$\begin{aligned} \therefore S_2 - S_1 = dS &= mC_p \ln \left(\frac{T_2}{T_1} \right) \\ &= 8 \times 4200 \times \ln \left(\frac{288.2}{288} \right) = 23 \text{ W/K} \end{aligned}$$



25. Ans: 6.68 kJ/K

Sol: H₂O T₁ = 0°C = 273K

↓

H₂O T₂ = 164.97°C = 437.97K

↓

Steam T₃ = 164.97°C = 437.97K

$$(dS)_1 = \int_{T_1}^{T_2} \frac{dQ}{T} = mC_{pw} \ln \left(\frac{T_2}{T_1} \right)$$

$$= 1 \times (4.187) \ln \left(\frac{437.97}{273} \right)$$

$$(dS)_1 = 1.97 \text{ kJ/kg.K}$$

$$(dS)_2 = \frac{Q}{T} = \frac{m \times L.H}{T} = \frac{1 \times (2066.3)}{437.97}$$

$$\Rightarrow (dS)_2 = 4.71 \text{ kJ/kg.K}$$

$$(dS)_{\text{Universe}} = (dS)_1 + (dS)_2$$

$$\Rightarrow (dS)_{\text{Universe}} = 6.68 \text{ kJ/kg.K}$$

26.

Sol:

(a): Given Carnot cycle

$$ds = 1.44 \text{ kJ/kgK}$$

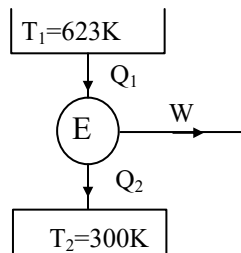

$$\eta_{\text{Carnot}} = \frac{T_1 - T_2}{T_1} = \frac{623 - 300}{623} = 0.518$$

$$\eta = \frac{W}{Q_1}$$

$$W = Q_1 \times \eta = T_1 dS \times \eta$$

$$W = 623 \times 1.44 \times 0.518 = 464.7 \text{ kJ}$$

(b) Given

Power = 20 kW

$$\text{Power (kW)} = \dot{m}_s \left(\frac{\text{kg}}{\text{sec}} \right) \times W \left(\frac{\text{kJ}}{\text{kg}} \right)$$

$$\Rightarrow \dot{m}_s = 0.043 \text{ kg/sec}$$

$$= 0.043 \times 3600 \text{ kg/hr}$$

$$\dot{m}_s = 154.8 \text{ kg/hr}$$

27. Ans: -16.01 J/K

Sol: Water T₁ = 20°C = 293 K

↓

Water T₂ = 0°C = 273 K

↓

Ice T₂ = 0°C = 273K

↓

Ice T₃ = -10°C = 263K

m = 10 g, C_p = 4.2 J/gK

$$dS_1 = mC_p \ln \frac{T_2}{T_1} = 10 \times 4.2 \times \ln \left(\frac{273}{293} \right)$$

$$= -2.96 \text{ J/K}$$

$$dS_2 = \frac{-m_i L_{\text{ice}}}{T_2} = \frac{-10 \times 335}{273} = -12.27 \text{ J/K}$$

$$dS_3 = mC_{p_{\text{ice}}} \ln \frac{T_3}{T_2} = 10 \times 2.1 \ln \left(\frac{263}{273} \right)$$

$$= -0.78 \text{ J}$$

$$(dS)_{\text{system}} = dS_1 + dS_2 + dS_3$$

$$= -2.96 - 12.27 - 0.78$$

$$= -16.01 \text{ J/K}$$



28.

Sol:

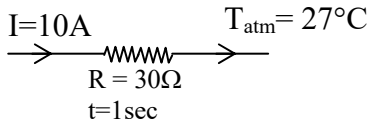

$$m_w = 10 \text{ gm}, \quad C_{pw} = 0.9 \times 10^3$$

With work transfer there is no entropy change so entropy change of resistor is equal to zero.

$$(dS)_{\text{Resistor}} = 0$$

$$(ds)_{\text{surrounding}} = \frac{Q}{T_{\text{atm}}} = \frac{I^2 R t}{T_{\text{atm}}} = \frac{10^2 \times 30 \times 1}{300} = 10 \text{ J/K}$$

$$(dS)_{\text{universe}} = (dS)_{\text{resistor}} + (dS)_{\text{surrounding}} = 10 \text{ J/K}$$

When it is insulated:

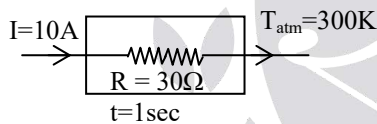

Heat gained by wire = work done = $I^2 R t$

$$m_w \times C_{pw} \times (T_2 - T_{\text{atm}}) = I^2 R t$$

$$10 \times 10^{-3} (0.9 \times 10^3) (T_2 - 300) = 10^2 \times 30 \times 1$$

$$T_2 = 633 \text{ K}$$

$$(dS)_{\text{wire}} = \frac{dQ}{T} = m_{\text{wire}} \times C_{p\text{wire}} \times \ln \frac{T_2}{T_1}$$

$$= (10 \times 10^{-3}) \times (0.9 \times 10^3) \times \ln \left(\frac{633}{300} \right)$$

$$= 6.720 \text{ J/K}$$

$$(dS)_{\text{surrounding}} = 0$$

$$(dS)_{\text{universe}} = 6.720 + 0 = 6.72 \text{ J/K}$$

29.

Sol: Case - 1:

Copper block

$$m = 600 \text{ g}, \quad C_p = 150 \text{ J/k}, \quad T_1 = 100^\circ\text{C}$$

Lake Temperature = $8^\circ\text{C} = T_2$

Find: $(dS)_{\text{universe}}$

If C_p is in J/K means mass is included and it is known as heat capacity.)

$$(dS)_{\text{Cu block}} = m C_p \ln \frac{T_2}{T_1} = 150 \ln \left(\frac{281}{373} \right)$$

$$\Rightarrow (dS)_{\text{Cu block}} = -42.48 \text{ J/K}$$

$$(dS)_{\text{H}_2\text{O}} = \frac{m C_p (T_2 - T_1)}{T_2}$$

$$= 150 \frac{(373 - 281)}{281} = 49.11 \text{ J/K}$$

$$\Rightarrow (dS)_{\text{universe}} = (dS)_{\text{Cu block}} + (dS)_{\text{H}_2\text{O}}$$

$$= -42.48 + 49.11$$

$$(dS)_{\text{universe}} = 6.626 \text{ J/K}$$

Case - 2 :

Same block, $T_2 = 8^\circ\text{C} = 281 \text{ K}$

As it is dropped from certain height, so there is change in potential energy. Work is done by the block

Change in entropy due to work interaction = 0

$$\Rightarrow (dS)_{\text{block}} = 0$$

$$(dS)_{\text{H}_2\text{O}} = \frac{Q}{T_2} = \frac{mgh}{T_2} = \frac{0.6 \times 9.81 \times 100}{281}$$

$$= 2.09 \text{ J/K}$$

$$\Rightarrow (dS)_{\text{Uni}} = 2.09 \text{ J/K}$$



Case - 3

Now by joining two blocks find $(dS)_{uni}$

$$T_1 = 100^\circ\text{C}, T_2 = 0^\circ\text{C}$$

Heat lost by block -1 = Heat gained by
block -2

$$C(T_1 - T_f) = C(T_f - T_2)$$

$$T_f = \frac{T_1 + T_2}{2} = 50^\circ\text{C}$$

$$\begin{aligned} \Rightarrow (dS)_{\text{block1}} &= C \ln\left(\frac{T_f}{T_1}\right) \\ &= 150 \ln\left(\frac{50 + 273}{373}\right) = -21.58 \text{ J/K} \end{aligned}$$

$$\begin{aligned} \Rightarrow (dS)_{\text{Block2}} &= C \ln\left(\frac{T_f}{T_2}\right) \\ &= 150 \ln\left(\frac{50 + 273}{273}\right) = +25.22 \text{ J/K} \end{aligned}$$

$$\Rightarrow (dS)_{\text{Uni}} = -21.58 + 25.22$$

$$\Rightarrow (dS)_{\text{Uni}} = 3.64 \text{ J/K}$$

$$(dS)_{\text{Universe}} > 0$$

So it is an irreversible process.

$$\begin{aligned} (dS)_{\text{H}_2\text{O}} &= \int_{T_2}^{T_1} \frac{dQ}{T} = \int_{T_2}^{T_1} m_w C_{Pw} \frac{dT}{T} \\ &= mC_p \ln\left(\frac{T_1}{T_2}\right) \end{aligned}$$

$$(dS)_{\text{Reservoir}} = -\frac{Q}{T_1} = \frac{-m_w C_{Pw} \times (T_1 - T_2)}{T_1}$$

$$\begin{aligned} (dS)_{\text{Universe}} &= (dS)_{\text{H}_2\text{O}} + (dS)_{\text{surr}} \\ &= m_w C_{Pw} \left[\ln\left(\frac{T_1}{T_2}\right) - \left(\frac{T_1 - T_2}{T_1}\right) \right] \\ &= 1(4.187) \times \left[\ln\left(\frac{373}{273}\right) - \left(\frac{373 - 273}{373}\right) \right] \end{aligned}$$

$$(dS)_{\text{universe}} = 0.183 \text{ kJ/kg.K}$$

(b)

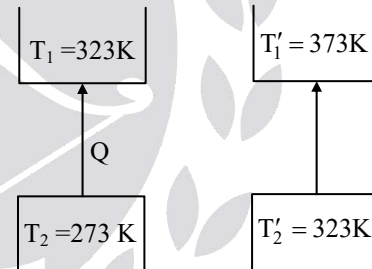

By providing one more reservoir at 323 K

1st stage, $(dS)_{\text{universe, 1st}}$

$$\Rightarrow (ds)_{\text{universe1}} = m_w C_{Pw} \left[\ln\left(\frac{T_1}{T_2}\right) - \left(\frac{T_1 - T_2}{T_1}\right) \right]$$

$$\begin{aligned} (dS)_{\text{univ, 1st stage}} &= 1 \times 4.18 \left[\ln\left(\frac{323}{273}\right) - \left(\frac{323 - 273}{323}\right) \right] \\ &= 0.056 \text{ kJ/kg.K} \end{aligned}$$

$\Rightarrow (ds)_{\text{univ, 2nd stage}}$

$$\begin{aligned} &= 1 \times 4187 \left[\ln\left(\frac{373}{323}\right) - \left(\frac{373 - 323}{373}\right) \right] \\ &= 0.041 \text{ kJ/kg.K} \end{aligned}$$

30.

Sol:

(a)

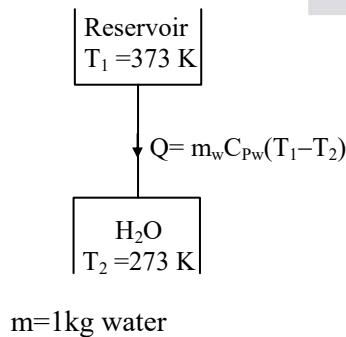



$$\begin{aligned} (dS)_{\text{universe}} &= (dS)_{\text{univ, 2ndstage}} + (dS)_{\text{univ, 1ststage}} \\ &= 0.041 + 0.056 = 0.097 \text{ kJ/kgK} \\ (dS)_{\text{uni}} &= 0.097 \text{ kJ/kg.K} \end{aligned}$$

(c) From above problem, when compared to single stage heating in a two stage heating entropy is halved. As the no. of stages of heating goes on increasing, entropy change of universe are decreasing. This way we can heat the fluid with almost no change in entropy of universe.

31.

Sol: Given $C_p = a + bT$.

$$\begin{aligned} Q &= \int_1^2 dQ = \int_{T_1}^{T_2} mC_p dT = \int_{T_1}^{T_2} m(a + bT) dT \\ &= \int_{T_1}^{T_2} ma dT + \int_{T_1}^{T_2} mbT dT \end{aligned}$$

$$Q = a\{T_2 - T_1\} + \frac{b}{2}[T_2^2 - T_1^2]$$

$$\int_{S_1}^{S_2} dS = \int_{T_1}^{T_2} mC_p \frac{dT}{T}$$

$$\Rightarrow dS = (S_2 - S_1) = \int_{T_1}^{T_2} m(a + bT) \frac{dT}{T}$$

$$\Rightarrow (S_2 - S_1) = am \ln \left[\frac{T_2}{T_1} \right] + bm[T_2 - T_1]$$

$$C_p = a + bT$$

$$25.2 \times 10^3 = a + b \times 500 \quad \dots \dots \dots (1)$$

$$30.1 \times 10^3 = a + b \times 1200 \quad \dots \dots \dots (2)$$

By solving

$$a = 21700, \quad b = 7$$

$$Q = 21,700(1200 - 500) + \frac{7}{2}(1200^2 - 500^2)$$

$$= 19355 \text{ J}$$

$$dS = 21700 \left(\frac{1200}{500} \right) + 7(1200 - 500)$$

$$= 2897.6716 \text{ J/K}$$

32.

Sol:

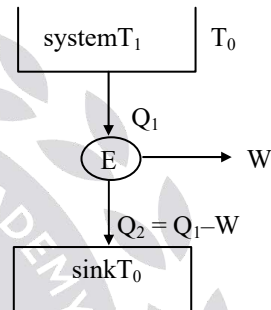

For maximum work done condition the engine has to be reversible and for the condition of reversibility entropy change of universe is zero.

$$(dS)_{\text{system}} = \int_{T_1}^{T_0} \frac{dQ}{T}$$

$$\int_{T_1}^{T_0} \frac{C_v dT}{T} = C_v \ln \left(\frac{T_0}{T_1} \right)$$

$$(dS)_{\text{surrounding}} = \frac{Q_1 - W}{T_0} = \frac{C_v(T_1 - T_0) - W}{T_0}$$

$$(dS)_{\text{univ}} = (dS)_{\text{system}} + (dS)_{\text{sink}} = 0$$

$$C_v \ln \left(\frac{T_0}{T_1} \right) + \frac{C_v(T_1 - T_0) - W}{T_0} = 0$$

$$W = C_v(T_1 - T_0) + T_0 C_v \ln \left(\frac{T_0}{T_1} \right)$$

$$= C_v \left[(T_1 - T_0) + T_0 \ln \left(\frac{T_0}{T_1} \right) \right]$$



33. Ans: (c)

Sol:

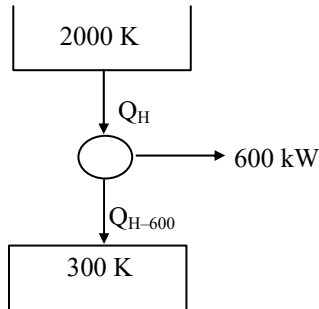

$$W_{\text{output}} = \left(\frac{T_H - T_L}{T_H} \right) \times Q_H$$

$$\left(\frac{2000 - 300}{2000} \right) \times Q_H = 600$$

$$Q_H = 705.89$$

Entropy change of working fluid during heat

$$\text{addition process} = \frac{705.89}{2000} = 0.353 \text{ kW/K}$$

34. Ans: (b)

Sol:

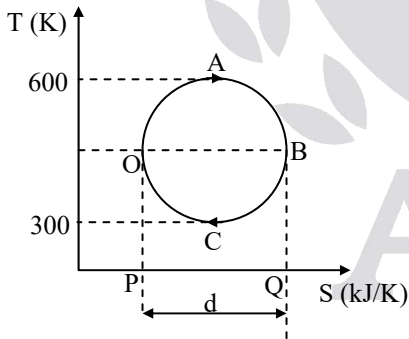

$$W_{\text{net}} = \text{Area of cycle OABC}$$

$$= \frac{\pi}{4} \times 300 \times d = 75\pi d$$

Heat supplied,

$Q_s = \text{Area of semicircle OAB} + \text{Area of rectangle OBQP}$

$$= \frac{\pi}{4} \times 300 \times d + 450 \times d$$

$$= (37.5\pi + 450)d$$

$$\eta_{\text{th}} = \frac{W_{\text{net}}}{Q_s}$$

$$= \frac{75\pi d}{(37.5\pi + 450)d} = 41.5\%$$

35.

Sol: Net work, $W_{\text{net}} = \text{Area of } \Delta ABC$

$$= \frac{1}{2} \times (400) \times (5 - 1)$$

$$= 800 \text{ kJ}$$

Heat supplied,

$Q_s = \text{Area of rectangle enclosed by line BC}$

$$= 800 \times (5 - 1) = 3200 \text{ kJ}$$

$$\eta = \frac{W_{\text{net}}}{Q_s} = \frac{800}{3200} = 25\%$$



Chapter- 6
Availability

01. Ans: (b)

Sol: Whenever certain quantity of heat transferred from a system available energy decrease

02. Ans: (d)

Sol: Irreversibility is zero in the case of Reversible process

03. Ans: (b)

04. Ans: 26.77 kJ

Sol:

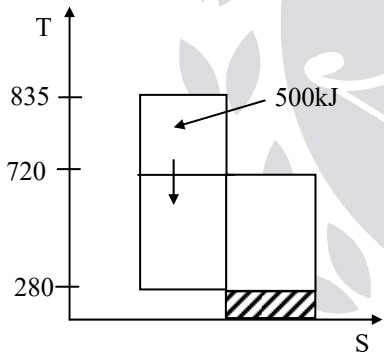

$$\begin{aligned} \text{Loss in A.E} &= T_0 S_{\text{gen}} \\ &= 280 \left(\frac{Q}{T_2} - \frac{Q}{T_1} \right) \\ &= 280 \left[\frac{500}{720} - \frac{500}{835} \right] \end{aligned}$$

$$\text{Loss in A.E} = 26.77 \text{ kJ}$$

05. Ans: 11.2 kJ, 5.25 kJ

Sol:

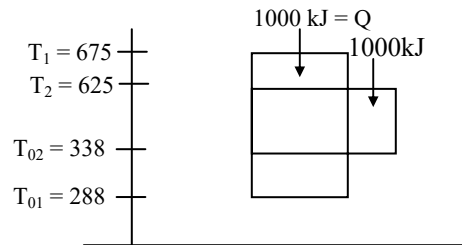

$$AE = Q \left(1 - \frac{T_0}{T} \right) = 1000 \left(1 - \frac{288}{675} \right) = 57.33 \text{ kJ}$$

$$AE_I = Q \left(1 - \frac{T_{02}}{T_2} \right) = 1000 \left(1 - \frac{338}{625} \right) = 45.92 \text{ kJ}$$

$$\begin{aligned} \text{Loss of available energy} &= 57.33 - 45.92 \\ &= 11.41 \text{ kJ} \end{aligned}$$

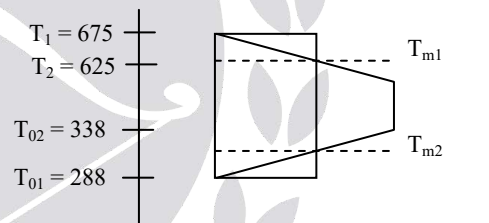

$$T_{m1} = \frac{T_1 + T_2}{2} = \frac{675 + 625}{2} = 650 \text{ K}$$

$$T_{m2} = \frac{T_{01} + T_{02}}{2} = \frac{288 + 338}{2} = 313 \text{ K}$$

$$\begin{aligned} AE_{II} &= Q \left(1 - \frac{T_{m2}}{T_{m1}} \right) \\ &= 1000 \left(1 - \frac{313}{650} \right) = 51.84 \text{ kJ} \end{aligned}$$

$$\begin{aligned} \text{Loss in AE} &= AE_I - AE_{II} \\ &= 57.33 - 51.84 = 5.49 \text{ kJ} \end{aligned}$$



06. Ans: 5743 kJ

Sol: Given Ideal gas , $n = 1$ k mol

$$P_1 = 1 \text{ MPa}, \quad P_2 = 0.1 \text{ MPa},$$

$$T_1 = 300 \text{ K} \quad T_f = T_1$$

$T = \text{constant} \Rightarrow$ isothermal process

For isothermal process,

$$s_2 - s_1 = mR \ln \left(\frac{P_1}{P_2} \right)$$

$$= n \bar{R} \ln \left(\frac{P_1}{P_2} \right)$$

For Non-flow process

$$W_{\max} = (u_1 - u_2) - T_0(s_1 - s_2)$$

$$W_{\max} = -T_0(s_1 - s_2) \quad (\because T = \text{constant})$$

$$W_{\max} = T_0 n \bar{R} \ln \left(\frac{P_1}{P_2} \right) = -T_0(s_1 - s_2)$$

$$= T_0(s_2 - s_1)$$

$$= 300 (1) (8.314) \ln \left(\frac{1}{0.1} \right)$$

$$\therefore W_{\max} = 5743 \text{ kJ}$$

07. Ans: 222.7 kJ

Sol: $P_1 = 1.4 \text{ MPa} = 1400 \text{ kPa}$

$$T_1 = 175 + 273 = 448 \text{ K}; \quad V = 1 \text{ m}^3$$

$$m = \frac{P_1 V}{RT_1} = \frac{1400 \times 1}{0.287 \times 448} = 10.88 \text{ kg}$$

$$T_2 = 25^\circ\text{C} = 298 \text{ K}$$

$$T_0 = 25^\circ\text{C} = 298 \text{ K}$$

$V = \text{constant}$

$$\frac{P_1}{T_1} = \frac{P_2}{T_2}$$

$$\frac{1400}{448} = \frac{P_2}{298}$$

$$P_2 = 931.25 \text{ kPa}$$

Non flow process:

Availability at state I

$$AE_I = (u_1 - u_0) - T_0(s_1 - s_0)$$

$$= C_v(T_1 - T_0) - T_0 \left(C_p \ln \frac{T_1}{T_0} - R \ln \frac{P_1}{P_0} \right)$$

$$= 0.718 (448 - 298) - 298$$

$$\left(1.005 \ln \frac{448}{298} - 0.287 \ln \frac{1400}{100} \right)$$

$$= 211.3 \text{ kJ/kg}$$

Availability at state 2

$$AE_{II} = (u_2 - u_0) - T_0(s_2 - s_0)$$

$$= C_v(T_2 - T_0) - T_0 \left(c_p \ln \frac{T_2}{T_0} - R \ln \frac{P_2}{P_0} \right)$$

$$= 0.718 (298 - 298) - 298$$

$$\left(1.005 \ln \frac{298}{298} - 0.287 \ln \frac{931.15}{100} \right)$$

$$= 190.82 \text{ kJ}$$

Loss in AE = 20.47 kJ/kg

Total Irreversibility

$$I = m \times \text{loss in AE} = 222.7 \text{ kJ}$$

08.

Sol:

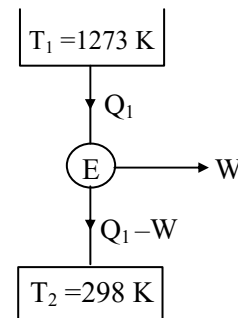

Maximum work obtained if reaction products could be directly used in heat engine.

Maximum work (A.E₁) = Q - T₀dS

$$\begin{aligned} A.E_1 &= mC_p \left[(T_1 - T_2) - T_0 \ln \left(\frac{T_1}{T_2} \right) \right] \\ &= \frac{5000}{3600} \left[(1273 - 298) - 298 \ln \left(\frac{1273}{298} \right) \right] \end{aligned}$$

$$A.E_1 = 753.18 \text{ kW}$$

Now as per given

Heat gained by air = Heat lost by gas

$$\begin{aligned} \dot{m}_a C_{p_a} (\Delta T)_a &= \dot{m}_g C_{p_g} (\Delta T)_g \\ \dot{m}_a \times 1(300 - 25) &= \frac{5000}{3600} (1)(1273 - 298) \end{aligned}$$

$$\dot{m}_a = 4.92 \text{ kg/sec}$$

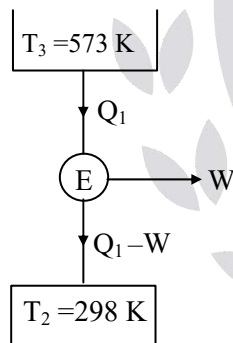

Now it is done by diffusion process

$$\begin{aligned} A.E_2 &= \dot{m}_a C_{p_a} \left[(T_3 - T_2) - T_0 \ln \left(\frac{T_3}{T_2} \right) \right] \\ &= 4.92(1) \left[(573 - 298) - (298 \ln \left(\frac{573}{298} \right)) \right] \end{aligned}$$

$$A.E_2 = 394.7 \text{ kW}$$

$$\text{Loss in A.E} = A.E_1 - A.E_2 = 753.18 - 394.7$$

$$\text{Loss in A.E} = 358.48 \text{ kW}$$

09. Ans: 25.83 kJ

Sol: Loss in available Energy in pipe

$$\begin{aligned} (\Delta E)_{\text{lost}} &= mRT_0 \left(\frac{\Delta p}{p_1} \right) \\ &= 3 \times 0.287 \times 300 \left(\frac{0.1 p_1}{p_1} \right) \\ &= 3 \times 0.287 \times 300 (0.1) \end{aligned}$$

$$(\Delta E)_{\text{Lost}} = 25.83 \text{ kJ}$$

10. Ans: 7.04 %

Sol:

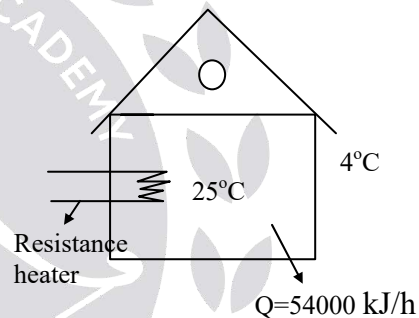

Second law efficiency,

$$\eta_{II} = \frac{W_{\text{rev}}}{W_{\text{act}}} \text{ or } \frac{(COP)_{\text{act}}}{(COP)_{\text{rev}}}$$

$$(COP)_{\text{rev}} = \frac{T_H}{T_H - T_L} = \frac{298}{21}$$

$$(COP)_{\text{act}} = 14.19$$

$$(COP)_{\text{act}} = \frac{\text{Heating effect}}{\text{Work input}}$$

For resistance heater, the entire work in heating is lost as heat

$$\therefore (COP)_{\text{act}} = \frac{54000}{54000}$$



$$(\text{COP})_{\text{act}} = 1$$

$$\eta_{\text{II}} = \frac{1}{14.19}$$

$$\eta_{\text{II}} = 7.04 \%$$

11. Ans: 0.962

Sol:
$$\eta_{\text{II}} = \frac{\eta_{\text{actual}}}{\eta_{\text{reversible}}}$$

$$\eta_{\text{actual}} = \frac{(1000 - 20) - (300 + 20)}{(1000 - 20)} = 0.6734$$

$$\eta_{\text{reversible}} = \frac{(1000 - 300)}{1000} = 0.7$$

$$\eta_{\text{II}} = \frac{0.6734}{0.7} = 0.962$$

Chapter- 7
Properties of Pure Substance

01. Ans: (d)

Sol:
$$\frac{T_2}{T_1} = \left(\frac{P_2}{P_1}\right)^{\frac{n-1}{n}}$$

02. Ans: (b)

03.

Sol: Given Non flow process & adiabatic system

$$m = 1\text{ kg at } P_1 = 700 \text{ kPa, } T_1 = 300^\circ\text{C,}$$

$$v_1 = 0.371 \text{ m}^3/\text{kg}, \quad h_1 = 3059 \text{ kJ/kg}$$

Due to Paddle work

$$T_2 = 400^\circ\text{C,} \quad v_2 = 0.44 \text{ m}^3/\text{kg,}$$

$$P_2 = 700 \text{ kPa,} \quad h_2 = 3269 \text{ kJ/kg}$$

At $P_1 = 700 \text{ kPa}$ from pressure Table

$$T_{\text{sat}} = 164.95^\circ\text{C}$$

$\Rightarrow T_1 > T_{\text{sat}}$ so it is in super heated state.

$$u_1 = h_1 - P_1 v_1 = 3059 - (700 \times 0.371)$$

$$= 2799.3 \text{ kJ/kg}$$

$$u_2 = h_2 - P_2 v_2 = 3269 - 700 \times 0.44$$

$$= 2961 \text{ kJ/kg}$$

It is a non flow process

$$P = C$$

$${}_1W_2 = P(v_2 - v_1) = 700(0.44 - 0.371)$$

$$W_s = {}_1W_2 = 48.3 \text{ kJ/kg}$$

For non flow process

$$u_1 + Q = u_2 + W$$



$$W = W_S + W_P = Q + (u_1 - u_2)$$

$$\begin{aligned} W_P &= Q + (u_1 - u_2) - W_S \\ &= 0 + (2800 - 2961) - 48.3 \\ &= -209.3 \text{ kJ/kg} \end{aligned}$$

04.

Sol: Given Non flow constant volume process

$$P_1 = 1.5 \text{ MPa} \quad x_1 = 0.9$$

$$V = 0.03 \text{ m}^3 \quad P_2 = 500 \text{ kPa}$$

$$v_1 = x_1 v_g = 0.9 \times 0.132 = 0.1188 \text{ m}^3/\text{kg}$$

$$h_1 = h_f + x_1 h_{fg} = 845 + 0.9 \times 1947 = 2597.3 \text{ kJ/kg}$$

$$u_1 = h_1 - P_1 v_1 = 2597.3 - (1500 \times 0.1188)$$

$$u_1 = 2419.1 \text{ kJ/kg}, \quad V = 0.03 \text{ m}^3$$

$$(i) \text{ Mass of wet steam} = \frac{V}{v_1} = \frac{0.03}{0.1188} = 0.253 \text{ kg}$$

$$V = C \text{ (Rigid vessel)}$$

$$v_1 = v_2 = x_2 v_{g2}$$

$$0.1188 = x_2 (0.375)$$

$$(ii) \quad x_2 = 0.317$$

$$h_2 = h_{f_2} + x_2 h_{fg_2} = 640 + 0.317 \times 2109$$

$$h_2 = 1308.55 \text{ kJ/kg}$$

$$u_2 = h_2 - P_2 v_2 = 1308.55 - 500 \times 0.1188$$

$$= 1249.15 \text{ kJ/kg}$$

$$(iii) \quad \Delta H = m(h_2 - h_1) = -1288.75 \times 0.253 \\ = -326.054 \text{ kJ}$$

$$\Delta U = m(u_2 - u_1) = 0.253(1249.15 - 2419.1)$$

$$\Delta U = -295.997 \text{ kJ}$$

$$\text{For constant volume } dV = 0, \quad W_2 = 0$$

$$(iv) \quad {}_1Q_2 = m(u_2 - u_1) = \Delta U$$

$$\Delta U = -295.997 \text{ kJ}$$

05. Ans: (d)

Sol: At $P = 1 \text{ atm}$, $h_{fg} = 2256.5 \text{ kJ/kg}$

$$\begin{aligned} \text{Power} &= \frac{\dot{m}_w \times h_{fg}}{\text{time}} = \frac{0.5 \times 2256.5}{18 \times 60} \\ &= 1.05 \text{ kW} \end{aligned}$$

06. Ans: (a)

Sol:

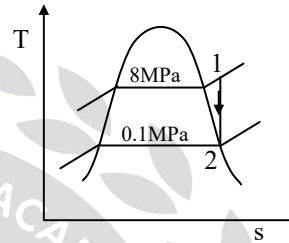

$$\dot{m} = 3 \text{ kg/sec}$$

By applying steady flow energy equation to turbine

$$\dot{m} h_1 + \dot{Q} = \dot{m} h_2 + \dot{W}$$

$$\dot{Q} = 0 \text{ (For adiabatic)}$$

$$\dot{W} = \dot{m}(h_1 - h_2)$$

$$\text{At } 8 \text{ MPa \& } 500^\circ \text{ C, } h_1 = 3399.5 \text{ kJ/kg}$$

$$\text{At } 0.1 \text{ MPa, } h_2 = h_{g_2} = 2675 \text{ kJ/kg}$$

$$\dot{W} = 3 \times (3399.5 - 2675) = 2173.5 \text{ kW}$$

07. Ans: (a)

Sol: At 200 kPa, $v_f = 0.001061 \text{ m}^3/\text{kg}$,

$$v_g = 0.8857 \text{ m}^3/\text{kg}$$

$$v = 300 \text{ m}^3, \quad P = 200 \text{ kPa}$$

$$m_f + m_v = m$$

$$v_f + v_v = v$$

$$(0.25 \times m \times 0.001061) + (0.75 \times m \times 0.8857) = 300$$

$$m = 451.44 \text{ kg}$$



08. Ans: (d)

Sol: At $P = 10 \text{ MPa}$, $T_{\text{sat}} = 311^\circ\text{C}$

$$T = 500^\circ\text{C}$$

$T > T_{\text{sat}} \rightarrow$ superheated state

At 10 MPa and 500°C

$$v = 0.032811 \text{ m}^3/\text{kg}$$

$$\text{Mass} = \frac{V}{v} = \frac{3}{0.032811} = 91.43 \text{ kg}$$

09. Ans: (a)

Sol:

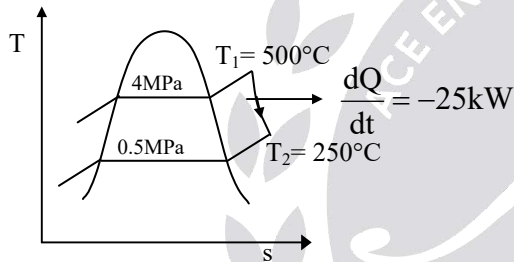

From tables

$$h_1 = 3446 \text{ kJ/kg}$$

$$h_2 = 2961 \text{ kJ/kg}$$

$$\dot{m} = 1350 \text{ kg/hr}$$

Applying first law

$$\dot{m}h_1 + \frac{dQ}{dt} = \dot{m}h_2 + \frac{dW}{dt}$$

$$\frac{dW}{dt} = \dot{m}(h_1 - h_2) + \frac{dQ}{dt}$$

$$= \frac{1350}{3600} [3446 - 2961] - 25$$

$$= 156.875 \text{ kW}$$

10.

Sol:

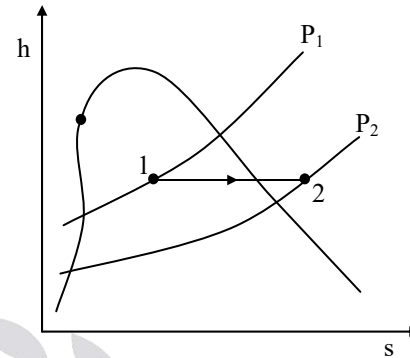

$$P_1 = 3 \text{ MPa} = 30 \text{ bar,}$$

$$h_{f_1} = 1008.41 \text{ kJ/kg, } h_{fg} = 1795.7 \text{ kJ/kg}$$

$$P_2 = 0.1 \text{ MPa, } T_2 = 120^\circ\text{C}$$

From steam tables

At $P_2 = 0.1 \text{ MPa}$,

$$T_{\text{sat}} = 99.61^\circ\text{C} \text{ and } T_2 = 100^\circ\text{C,}$$

$T_2 > T_{\text{sat}}$ (superheated)

$$h = 2676.2 \text{ kJ/kg}$$

At $P_2 = 0.1 \text{ MPa}$ and $T_2 = 150^\circ\text{C}$

$$h = 2776.4 \text{ kJ/kg}$$

At $P_2 = 0.1 \text{ MPa}$ and $T_2 = 120^\circ\text{C}$,

$$h_2 = ?$$

$$150^\circ\text{C} \rightarrow 2776.6 \text{ kJ/kg}$$

$$100^\circ\text{C} \rightarrow 2675.8 \text{ kJ/kg}$$

$$dT = 50^\circ\text{C} \rightarrow dh = 100.8 \text{ kJ/kg}$$

$$dT' = 30^\circ\text{C} \rightarrow x = 60.48 \text{ kJ/kg}$$

$$\therefore h_2 = 2716.12 \text{ kJ/kg} = h_1$$

(For throttling process)

\therefore If dryness fraction is x

$$\therefore h_1 = h_{f_1} + xh_{fg_1}$$

$$1008.41 + x(1795.7) = 2716.12$$

$$\therefore x = 0.95$$



11.

Sol: Given separating & throttling calorimeter

$$P_1 = 15 \text{ bar} = P_2, m_1 = 0.55 \text{ kg}$$

$$T_1 = 198.3^\circ \text{C} = T_2, m_2 = 4.2 \text{ kg}$$

$$P_3 = 1 \text{ bar}, T_3 = 120^\circ \text{C}$$

$$\therefore h_3 = 2716.3 \text{ kJ/kg}$$

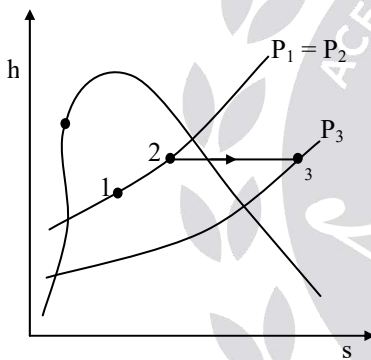
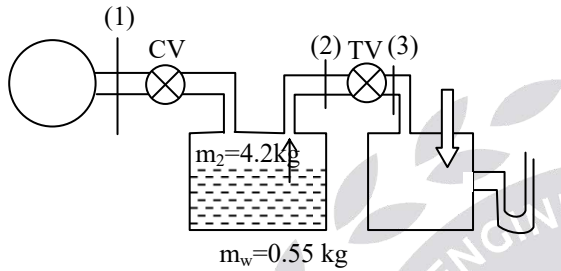

$$(\text{Dryness fraction})_{\text{separator}}, x_1 = \frac{m_2}{m_1 + m_2}$$

$$= \frac{4.2}{4.2 + 0.55} = 0.88$$

For throttling

$$h_2 = h_3$$

$$h_{f_2} + x_2 h_{fg_2} = h_3$$

$$844.55 + x_2 (1946.4) = 2716.2$$

$$x_2 = 0.9616$$

$$\begin{aligned} \text{Mass of vapour} = m_v &= x_2 m_2 = 0.96 \times 4.2 \\ &= 4.032 \text{ kg} \end{aligned}$$

(Dryness fraction)_{Boiler}

$$= x = \frac{m_v}{m_{\text{total}}} = 0.8488$$

As quality of steam at boiler is $< 90\%$ so only throttling calorimeter can not be used.

12.

Sol:

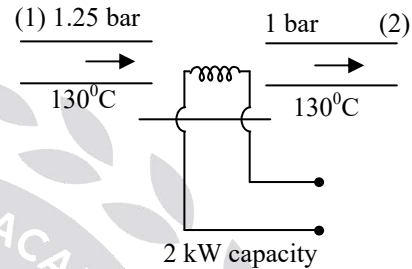

From steam tables

$$\text{At } 1 \text{ bar}, 150^\circ \text{C}, \quad h = 2675.8 \text{ kJ/kg}$$

$$\text{At } 1 \text{ bar}, 100^\circ \text{C}, \quad h = 2776.6 \text{ kJ/kg}$$

$$\text{At } 1 \text{ bar}, 130^\circ \text{C}, \quad h_2 = ?$$

$$P_2 = 100 \text{ kPa}, \quad T_{\text{sat}} = 99.61^\circ \text{C}$$

$$T_2 > T_{\text{sat}} \text{ (Superheated state)}$$

$$100^\circ \text{C} \rightarrow 2776.6 \text{ kJ/kg}$$

$$130^\circ \text{C} \rightarrow h_3 = ?$$

$$150^\circ \text{C} \rightarrow 2675.8 \text{ kJ/kg}$$

$$dT = 50^\circ \text{C} \rightarrow 100.8 \text{ kJ/kg}$$

$$dT' = 20^\circ \text{C} \rightarrow x$$

$$x = \frac{100.8 \times 20}{50} = 40.32 \text{ kJ/kg}$$

$$h_2 = 2776.6 - 40.32$$

$$h_2 = 2736.28 \text{ kJ/kg}$$

$$\dot{m} = \frac{3.4 \text{ kg}}{5 \text{ min}} = \frac{3.4}{300} = 0.0113 \text{ kg/s}$$

By steady flow energy equation

$$\dot{m} h_1 + \dot{Q} = \dot{m} h_2 - \dot{W}$$



$$h_1 = h_2 - \frac{\dot{Q}}{m}$$

$$= 2736.28 - \frac{2}{0.0113} = 2559.28 \text{ kJ/kg}$$

$$h_1 = h_{f_1} + xh_{fg_1} = 444.36 + x \times 2240.6$$

$$x = 0.9439$$

13. Ans: (a)

Sol: $v_1 = \text{specific volume} = \frac{0.025}{10} = 0.0025 \frac{\text{m}^3}{\text{kg}}$

$v_1 < v_c$ (critical volume) after heating at constant volume it goes into liquid region hence level of liquid in the vessel rises.

Chapter- 8
Air Cycles

01. Ans: (a)

Sol: 1-2 → Isothermal

3-1 → Adiabatic process

02. Ans: (d)

Sol: For Maximum specific output in case of Otto cycle, the temperature of working fluid at the end of compression and expansion should be equal

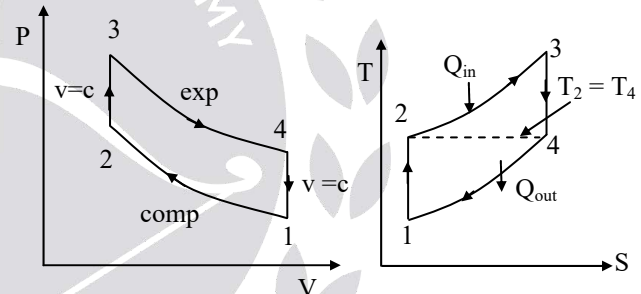

03. Ans: (c)

04. Ans: (c)

Sol: Otto cycle

05. Ans: (c)

Sol: $\eta_{\text{Carnot}} > \eta_{\text{Stirling}}$

(If 100% effectiveness of heat exchanger is given then carnot efficiency equals to stirling efficiency)



06. Ans: (d)

Sol: For equal r_k & heat rejected

$$\eta_{\text{Otto}} > \eta_{\text{Dual}} > \eta_{\text{Diesel}}$$

07. Ans: (a) and (d)

Sol: For same maximum pressure in Otto & Diesel cycle

$$\eta_{\text{Diesel}} > \eta_{\text{Otto}}$$

And $r_{k\text{Diesel}} > r_{k\text{Otto}}$

08. Ans: (c)

09.

Sol: $Q_s = 1500 \text{ kJ/kg}$, $P_1 = 100 \text{ kPa}$,

$$T_1 = 27^\circ\text{C} = 300 \text{ K}$$

$$r_k = 8 = \frac{V_1}{V_2} = \frac{8}{1} = \frac{V_4}{V_3}$$

$$(C_v)_{\text{air}} = 0.72 \text{ kJ/kgK}$$

For process 1-2

$$P_1 V_1^\gamma = P_2 V_2^\gamma$$

$$\Rightarrow P_2 = P_1 \left(\frac{V_1}{V_2} \right)^\gamma = 100 \times 8^{1.4}$$

$$= 1837.9 \text{ kPa}$$

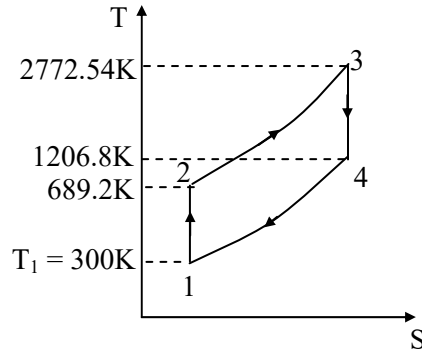
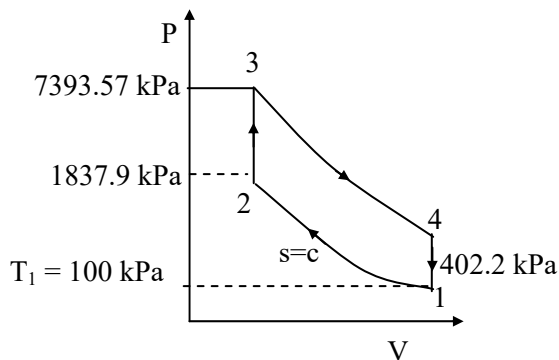

$$T_2 = T_1 \left(\frac{P_1}{P_2} \right)^{\frac{1-\gamma}{\gamma}} = 300 \times \left(\frac{100}{1837.9} \right)^{\frac{1-1.4}{1.4}}$$

$$= 689.2 \text{ K}$$

$$Q_s = C_v (T_3 - T_2) = 1500 \text{ kJ/kg}$$

$$\Rightarrow 0.72 \times (T_3 - 689.21) = 1500$$

$$T_3 = 2772.54 \text{ K}$$

Process 2 - 3

$$\Rightarrow \frac{P_2}{T_2} = \frac{P_3}{T_3}$$

$$\Rightarrow P_3 = P_2 \times \frac{T_3}{T_2} = 1837.9 \times \frac{2772.54}{689.2}$$

$$P_3 = 7393.57 \text{ kPa}$$

Process 3 - 4

$$\Rightarrow P_3 V_3^\gamma = P_4 V_4^\gamma$$

$$\Rightarrow P_4 = P_3 \times \left(\frac{V_3}{V_4} \right)^\gamma = 7393.47 \times \left(\frac{1}{8} \right)^{1.4}$$

$$\Rightarrow P_4 = 402.2 \text{ kPa}$$

$$T_3 V_3^{\gamma-1} = T_4 V_4^{\gamma-1}$$

$$\Rightarrow T_4 = 1206.8 \text{ K}$$

$$\eta_{\text{Otto}} = 1 - \frac{1}{(r_k)^{\gamma-1}} = 1 - \frac{1}{8^{1.4-1}}$$

$$\Rightarrow \eta_{\text{Otto}} = 0.56 = \frac{W}{1500} \Rightarrow W = 847 \text{ kJ/kg}$$



10. Ans: (c)

Sol: $V_c = 0.2 V_s$

$r_k = \text{Compression ratio}$

$$= \frac{V_s + V_c}{V_c} = \frac{V_s + 0.2V_s}{0.2V_s} = 6$$

$$\eta_{th} = 1 - \left(\frac{1}{r_k}\right)^{\gamma-1} = 1 - \left(\frac{1}{6}\right)^{1.4-1}$$

$$= 0.5116 \text{ or } 51.16\%$$

11.

Sol: $V_C = 2000 \text{ CC}$

$$V_s = \frac{\pi}{4} D^2 L = \frac{\pi}{4} \times 15^2 \times 45 = 7948.125 \text{ CC}$$

Compression Ratio

$$r_k = \frac{V_s + V_c}{V_c} = \frac{7948.125 + 2000}{2000}$$

$$= 4.974$$

$$\eta_{th} = 1 - \left(\frac{1}{r_k}\right)^{\gamma-1}$$

$$= 1 - \left(\frac{1}{4.974}\right)^{1.4-1} = 0.4376 \text{ or } 47.36\%$$

12. Ans: (a)

Sol: $r_k = \frac{V_1}{V_2} = \frac{2.5}{0.25} = 10,$

$$T_1 = 20^\circ\text{C} = 293\text{K}$$

$$\text{He} \rightarrow \gamma = \frac{5}{3}$$

$$T_2 = 293 \times 10^{\frac{5}{3}-1} = 1370.46 \text{ K}$$

$$T_3 - T_2 = 700^\circ\text{C}$$

$$T_3 = 700 + 1097.46 = 1797.46^\circ\text{C}$$

13.

Sol:

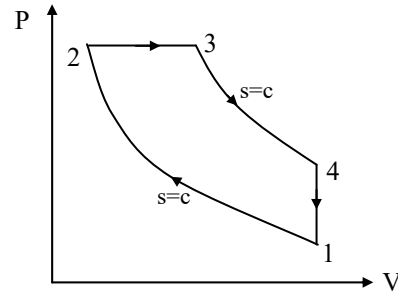

$$r_k = \frac{V_1}{V_2} = 15 \Rightarrow V_1 = 15V_2$$

$$V_3 - V_2 = \frac{6.5}{100} (V_1 - V_2) = \frac{6.5}{100} (15V_2 - V_2)$$

$$= 0.91 V_2$$

$$V_3 = 0.91V_2 + V_2 = 1.91V_2$$

$$r_c = \frac{V_3}{V_2} = 1.91$$

$$\eta_{th} = 1 - \frac{1}{\gamma \cdot r_k^{\gamma-1}} \cdot \frac{r_c^\gamma - 1}{r_c - 1}$$

$$= 1 - \frac{1}{1.4 \times 15^{0.4}} \cdot \left(\frac{1.91^{1.4} - 1}{1.91 - 1}\right) = 60.8\%$$

14. Ans: (c)

Sol: $V_1 = 3L,$

$$V_2 = 0.15L$$

Compression ratio

$$r_k = \frac{V_1}{V_2} = \frac{3}{0.15} = 20$$

$$r_c = \frac{V_3}{V_2} = \frac{0.30}{0.15} = 2$$



$$\eta_{\text{Diesel}} = 1 - \frac{1}{\gamma} \cdot \frac{1}{r_k^{\gamma-1}} \cdot \frac{r_c^\gamma - 1}{r_c - 1}$$

$$= 1 - \frac{1}{1.4} \times \frac{1}{(20)^{1.4-1}} \times \frac{2^{1.4} - 1}{(2-1)} = 0.6467$$

$$= 64.67\%$$

15. Ans: 63.44 %

Sol:

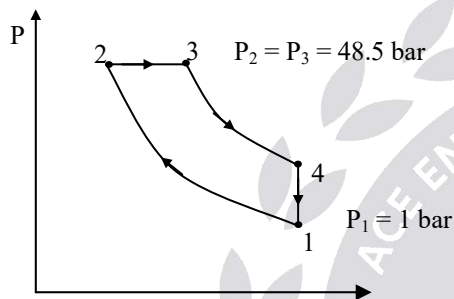

$$\text{Compression ratio} = r_k = \frac{V_1}{V_2}$$

$$\text{Expansion ratio} = r_E = \frac{V_4}{V_3} = \frac{V_1}{V_3} = 10$$

$$P_1 V_1^\gamma = P_2 V_2^\gamma$$

$$r_k = \frac{V_1}{V_2} = \left(\frac{P_2}{P_1}\right)^{\frac{1}{\gamma}} = \left(\frac{48.5}{1}\right)^{\frac{1}{1.4}} = 16$$

$$\text{Fuel cut off ratio} = r_c = \frac{V_3}{V_2} = \frac{r_k}{r_E} = \frac{16}{10} = 1.6$$

$$\eta_{\text{th}} = 1 - \frac{1}{\gamma \cdot r_k^{\gamma-1}} \left[\frac{r_c^\gamma - 1}{r_c - 1} \right]$$

$$= 1 - \frac{1}{(1.4)16^{(1.4-1)}} \left[\frac{1.6^{1.4} - 1}{1.6 - 1} \right]$$

$$= 1 - \frac{1}{1.4 \times 3.0314} \left[\frac{1.9309 - 1}{1.6 - 1} \right] = 0.6344$$

16. Ans: 235.5 kPa

$$\text{Sol: } D_1 = 500 - 200 = 300 \text{ kPa}$$

$$D_2 = 0.03 - 0.01 = 0.02 \text{ m}^3$$

$${}_1W_2 = \frac{\pi}{4} \times D_1 \times D_2$$

$${}_1V_2 = V_2 - V_1 = 0.03 - 0.01 = 0.02 \text{ m}^3$$

$$\text{mep} = \frac{\text{work done}}{\text{swept volume}} = \frac{{}_1W_2}{{}_1V_2} = \frac{\frac{\pi}{4} \times D_1 \times D_2}{(V_1 - V_2)}$$

$$= \frac{\frac{\pi}{4} \times 300 \times 0.02}{0.02}$$

$$= 75 \pi = 75 \times 3.14 = 235.5 \text{ kPa}$$

17. Ans: (b)

$$\text{Sol: Swept volume} = V_s = 0.03 \text{ m}^3$$

$$(\text{work})_{\text{net}} = \frac{\text{work(kW)}}{N(\text{rps})} = \frac{1000}{\frac{2000}{60}} = 30 \text{ kJ}$$

$$\text{mep} = \frac{W_{\text{net}}(\text{kJ})}{V_s(\text{m}^3)} = \frac{30}{0.03} = 1000 \text{ kPa} = 1 \text{ MPa}$$

18. Ans: (b)

$$\text{Sol: } v_1 = \frac{1}{\rho_1} = \frac{1}{1.2} = 0.833 \text{ m}^3 / \text{kg}$$

$$r_k = \frac{V_1}{V_2} = \frac{2.2}{0.26} = 8.46$$

$$V_2 = \frac{0.834}{8.46} = 0.098 \text{ m}^3 / \text{kg}$$

$$\text{mep} = \frac{W_{\text{net}}}{V_1 - V_2} = \frac{440}{0.833 - 0.098} = 598.8 \text{ kPa}$$



19.

$$\text{Sol: } \eta = 0.54 = 1 - \left(\frac{1}{r_k}\right)^{\gamma-1} = 1 - \left(\frac{1}{r_k}\right)^{0.4}$$

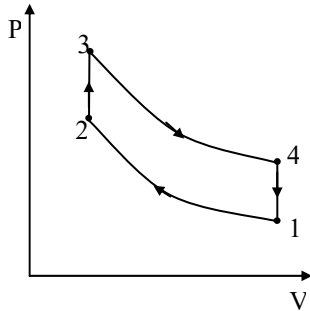

$$\left(\frac{1}{r_k}\right)^{0.4} = 0.46$$

$$r_k = \frac{1}{(0.46)^{2.5}} = 6.97$$

$$P_1 = 1 \text{ bar}$$

$$T_1 = 273 + 15 = 288 \text{ K}$$

$$P_3 = 75 \text{ bar}$$

$$P_2 = P_1 r_k^\gamma = 1 \times (6.97)^{1.4} = 15.154 \text{ bar}$$

$$T_2 = T_1 r_k^{\gamma-1} = 288(6.97)^{1.4-1} = 626.16 \text{ K}$$

$$T_3 = T_2 \times \frac{P_3}{P_2} = 626.16 \times \frac{75}{15.154} = 3099 \text{ K}$$

$$\text{Heat supplied} = C_v \times (T_3 - T_2) = 0.718(3099 - 626.16)$$

$$Q_s = 1775.5 \text{ kJ/kg}$$

$$\text{Work done} = \eta_{th} \times Q_s$$

$$W = 0.54 \times 1775.5 = 958.77 \text{ kJ/kg}$$

$$\text{Heat rejected} = Q_s - W = 1775.5 - 958.77 = 816.73 \text{ kJ/kg}$$

$$v_1 = \frac{RT_1}{P_1} = \frac{0.287 \times 288}{100} = 0.82656 \frac{\text{m}^3}{\text{kg}}$$

$$v_2 = \frac{RT_2}{P_2} = \frac{0.287 \times 626.16}{1515.4} = 0.1186 \frac{\text{m}^3}{\text{kg}}$$

$$\begin{aligned} \text{mep} &= \frac{W_{\text{net}} \left(\frac{\text{kJ}}{\text{kg}}\right)}{(v_1 - v_2) \left(\frac{\text{m}^3}{\text{kg}}\right)} = \frac{958.77}{0.82656 - 0.1186} \\ &= \frac{958.77}{0.70796} = 1354.27 \text{ kPa} \end{aligned}$$

20.

Sol:

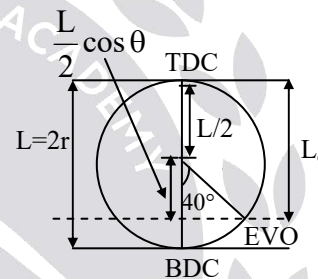

$$L = 14 \text{ cm}, \theta = 40^\circ, D = 10 \text{ cm}$$

Effective stroke length

$$\begin{aligned} L_e &= L/2 + \frac{L}{2} \cos \theta \\ &= 7 + 7 \cos 40 = 12.36 \text{ cm} \end{aligned}$$

Effective stroke volume

$$(V_s)_{\text{eff}} = \frac{\pi}{4} D^2 L_e = \frac{\pi}{4} \times 10^2 \times 12.36 = 970.75 \text{ cm}^3$$

$$V_C = 157 \text{ cm}^3$$

$$(r_k)_{\text{effective}} = \frac{(V_s)_{\text{eff}} + V_C}{V_C} = \frac{970.75 + 157}{157} = 7.18$$

$$\eta_{th} = 1 - \left(\frac{1}{r_k}\right)^{\gamma-1} = 1 - \left(\frac{1}{7.18}\right)^{0.4}$$

$$= 0.54 \text{ or } 54\%$$



21.

Sol:

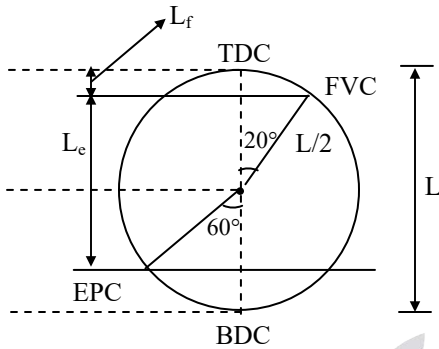

$$D = 10 \text{ cm}, \quad L = 14 \text{ cm}$$

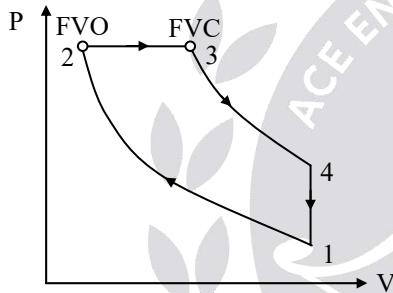

$$L_e = \frac{L}{2} + \frac{L}{2} \cos \theta = 7 + 7 \cos 60^\circ = 10.5 \text{ cm}$$

$$L_f = \frac{L}{2} - \frac{L}{2} \cos \theta_1$$

$$= 7 - 7 \cos 20^\circ = 0.42 \text{ cm}$$

$$(V_s)_{\text{eff}} = \frac{\pi}{4} D^2 L_e = \frac{\pi}{4} \times 10^2 \times 10.5$$

$$= 824.6 \text{ cm}^3$$

$$V_C = 40.2 \text{ cm}^3$$

$$(r_k)_{\text{effective}} = \frac{(V_s)_{\text{eff}} + V_C}{V_C} = 21.51$$

Volume corresponding to fuel cutoff

$$V_3 - V_2 = \frac{\pi}{4} D^2 L_f = \frac{\pi}{4} \times 10^2 \times 0.42$$

$$= 32.98 \text{ cc}$$

$$V_3 - 40.2 = 32.98.$$

$$V_3 = 73.18$$

$$r_c = \frac{V_3}{V_2} = \frac{73.18}{40.2} = 1.82$$

$$\eta_{\text{th}} = 1 - \frac{1}{\gamma r_k^{\gamma-1}} \cdot \frac{r_c^\gamma - 1}{r_c - 1}$$

$$= 1 - \frac{1}{1.4 \times (21.51)^{0.4}} \times \frac{1.82^{1.4} - 1}{1.82 - 1}$$

$$= 66.5\%$$

22.

$$\text{Sol: IP} = \frac{p_{\text{mi}} L A N n}{120,000}$$

$$= \frac{\frac{A_d}{L_d} \times k \times L \times A \times N \times n}{120000}$$

$$4 = \frac{\frac{A_d}{0.1L} \times 25 \times 10^6 \times L \times \frac{\pi}{4} (0.15)^2 \times 216 \times 1}{120000}$$

$$A_d = 503 \text{ mm}^2$$

Chapter- 9
Psychrometry

01. Ans: (b)

Sol:

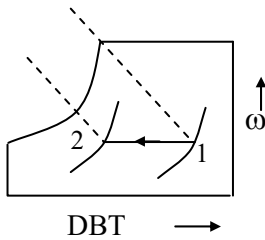

During sensible cooling of air
DBT decreases, WBT decreases, h decreases
and $\omega = \text{constant}$,
DPT = constant, R.H increases

02. Ans: (c)

Sol:

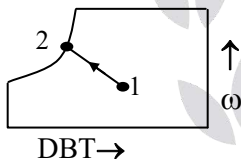

During adiabatic saturation process DBT
decreases, WBT = constant, h = constant,
specific humidity (ω) increases, DPT
increases, relative humidity increases.

03. Ans: (b)

Sol: When warm saturated air is cooled, excess
moisture condenses but relative humidity
remains unchanged

04. Ans: (c)

Sol: Case (A): Moist air is adiabatically saturated

Case (B): Moist air is isobarically saturated

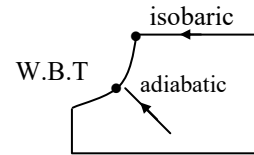

Case-(A): Adiabatically saturated \rightarrow W.B.T

Case-(B): isobarically saturated \rightarrow D.P.T

05. Ans (b)

Sol: For dehumidification, the coil temperature
should be less than the dew point
temperature of the incoming air.

06. Ans: (d)

Sol:

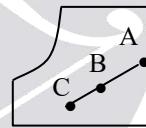

$$\text{By pass factor} = \frac{BC}{AC}$$

07. Ans: (b)

08. Ans: (d)

Sol:

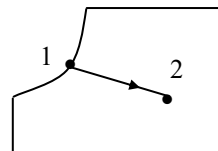

During chemical dehumidification
Enthalpy & W.B.T remains constant, specific
humidity decreases, dew point temperature
decreases and relative humidity decreases.



09. Ans: (c)

10. Ans: (a)

Sol: T_{coil} is greater than dew point temperature but less than dry bulb temperature hence it is sensible cooling.

11. Ans: (c)

Sol: Temperature of water spray is greater than dew point temperature hence it is a heating process and water molecules are mixing with air hence it is humidification.

12. Ans: (b)

Sol: Heat is absorbed so it is absorption or chemical process in which WBT remains constant & DBT increases.

13. Ans: (a)

$$\text{Sol: } \mu = \phi \times \left(\frac{P_{\text{atm}} - P_{\text{sat}}}{P_{\text{atm}} - P_v} \right) = \frac{P_b - P_s}{P_b - P_v} \times \phi$$

14. Ans: (a)

Sol:

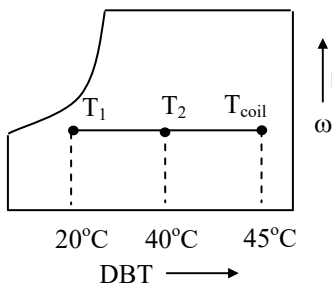

$$\text{By pass factor} = \frac{T_{\text{coil}} - T_2}{T_{\text{coil}} - T_1} = \frac{45 - 40}{45 - 20}$$

$$\text{BPF} = 0.2$$

15. Ans: (c)

Sol: L.H.L = 0.25 S.H.L

$$\text{S.H.F} = \frac{\text{SHL}}{\text{SHL} + \text{LHL}}$$

$$\text{S.H.F} = \frac{\text{S.H.L}}{1.25 \times \text{S.H.L}} = 0.8$$

16. Ans: (d)

Sol: $T_{\text{sat}} = 25^\circ\text{C} \rightarrow \phi = 100\%$

$$P_{\text{sat}} = 3.1698 \text{ kPa}$$

$$P_{\text{total}} = 100 \text{ kPa}$$

$$\phi = \frac{P_v}{P_{\text{sat}}} = 1 \Rightarrow P_v = P_{\text{sat}} = 3.1698 \text{ kPa}$$

$$\omega = 0.622 \frac{P_v}{P_{\text{atm}} - P_v} = 0.622 \times \frac{3.1698}{100 - 3.1698}$$

$$= 0.0204 \times \frac{\text{kg Vap}}{\text{kg dry air}}$$

$$\omega = \frac{m_v}{m_a}$$

$$m_v = 100 \times 0.0204 = 2.04 \text{ kg}$$

17. Ans: (c)

$$\text{Sol: } \omega = \frac{m_v}{m_a} = \frac{0.6}{50} = 0.012 \frac{\text{kg of Vapour}}{\text{kg of dry air}}$$

$$T_{\text{sat}} = 25^\circ\text{C},$$

$$P_{\text{sat}} = 3.1698 \text{ kPa}$$

$$\omega = 0.622 \frac{P_v}{95 - P_v} = 0.012$$

$$P_v = 1.798 \text{ kPa}$$

$$\phi = \frac{P_v}{P_{\text{sat}}} = \frac{1.798}{3.1698} = 0.567 = 56.7\%$$



18. Ans: (c)

Sol: $T_{\text{sat}} = 30^\circ\text{C} \rightarrow P_{\text{sat}} = 4.2469 \text{ kPa}$

$$P_{\text{atm}} = 90 \text{ kPa}, \quad \phi = \frac{P_v}{P_{\text{sat}}} = 75\%$$

$$P_v = 0.75 \times 4.2469 = 3.185 \text{ kPa}$$

$$P_a = P_{\text{atm}} - P_v$$

$$P_{\text{air}} = 86.815 \text{ kPa}$$

$$m_a = \frac{P_a V}{R_a T} = \frac{86.815 \times 40}{0.287 \times 303} = 39.93 \text{ kg}$$

19.

Sol: $T_{\text{sat}} = 30^\circ\text{C}$

$$P_{\text{atm}} = 100 \text{ kPa}$$

$$P_{\text{sat}} = 4 \text{ kPa}$$

$$\mu = 0.24 = \frac{P_v (P_{\text{atm}} - P_{\text{sat}})}{P_{\text{sat}} (P_{\text{atm}} - P_v)} = \frac{P_v (100 - 4)}{4(100 - P_v)}$$

$$400 \times 0.24 - 0.24 P_v = 100 P_v - 4 P_v$$

$$96.24 P_v = 400 \times 0.24$$

$$P_v = \frac{400 \times 0.24}{96.24} = 0.9975 \text{ kPa}$$

Relative humidity

$$\phi = \frac{P_v}{P_{\text{sat}}} = \frac{0.9975}{4} = 0.2493 \text{ or } 24.93\%$$

$$\omega = 0.622 \frac{P_v}{P_{\text{atm}} - P_v}$$

$$= 0.622 \times \frac{0.9975}{100 - 0.9975} = 0.00627 \frac{\text{kg.vap}}{\text{kg.d.a}}$$

20.

Sol: $P_{\text{atm}} = 101 \text{ kPa}$

$$T_{\text{sat}} = 40^\circ\text{C}$$

$$P_{\text{sat}} = 7.38 \text{ kPa}$$

$$\phi = 0.5 = \frac{P_v}{P_{\text{sat}}} = \frac{P_v}{7.38}$$

$$P_v = 3.692$$

$$\omega = 0.622 \frac{P_v}{P_{\text{atm}} - P_v}$$

$$= 0.622 \times \frac{3.692}{101 - 3.692}$$

$$\omega = 0.0235 \frac{\text{kgVap}}{\text{kg da}}$$

As gas is compressed partial pressure increases in the same ratio,

$$P_v = 3.692 \times \frac{5.05}{1.01}$$

At 150°C ,

$$P_{\text{sat}} = 475.8 \text{ kPa}$$

$$\phi = \frac{P_v}{P_{\text{sat}}} = \frac{18.46}{475.8} \times 100 = 3.9\%$$

21. Ans: 1.125 kPa

Sol: $P_1 = 100 \text{ kPa}$

$$P_2 = 500 \text{ kPa}$$

$$\text{DBT} = 35^\circ\text{C}$$

$$P_{\text{VS}} = 5.628 \text{ kPa}$$

$$\omega_s = 0.622 \times \frac{P_{\text{VS}}}{P_2 - P_{\text{VS}}} = 0.622 \times \frac{5.628}{500 - 5.628}$$

$$= 7.08 \times 10^{-3} \text{ kg vapour/kg dry air}$$

$$\omega_2 = \omega_s = 7.08 \times 10^{-3}$$

(\because pressure remains constant in after cooler)

Moisture is same throughout the process i.e.,

in compressor no moisture is removed or

added and in after cooler, the pressure is



constant so the moisture content will not change.

$$\omega_1 = 0.622 \times \frac{P_V}{P_1 - P_V}$$

$$\frac{7.08 \times 10^{-3}}{0.622} = \frac{P_V}{(100 - P_V)}$$

$$\therefore P_V = 1.125 \text{ kPa}$$

22. Ans: (d)

Sol: $T_{\text{sat}} = 20^\circ\text{C}$, $P_{\text{sat}} = 2.339 \text{ kPa}$

$$\phi = 0.5$$

$$\phi = \frac{P_V}{P_{\text{sat}}} \Rightarrow P_V = 0.5 \times 2.339 = 1.169 \text{ kPa}$$

Corresponding to partial pressure of vapor whatever the saturation temperature is the temperature at which the water vapor present in air starts condensing and this beginning of this condensation is called as dew point temperature.

At $5^\circ\text{C} \rightarrow 0.8725$

$$T_2 - ? \rightarrow P_2 = 1.169$$

$10^\circ\text{C} \rightarrow 1.2281$

$$\frac{1.2281 - 0.8725}{1.169 - 0.8725} = \frac{10 - 5}{T_2 - 5}$$

$$T_2 = 9.16^\circ\text{C}$$

23. Ans: (d)

Sol:

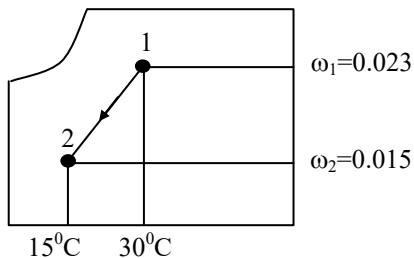

Cooling load on coil h_1

$$= C_{P_a}(T_1 - 0) + \omega_1 [(h_{fg})_{0^\circ\text{C}} + C_{P_V}(T_1 - 0)]$$

$$= 1.005 \times (30 - 0) + 0.023 [2500 + 1.88(30 - 0)]$$

$$= 88.94 \text{ kJ/kg of dry air}$$

$$h_2 = C_{P_a}(T_2 - 0) + \omega_2 [(h_{fg})_{0^\circ\text{C}} + C_{P_V}(T_2 - 0)]$$

$$= 1.005(15 - 0) + 0.015 [2500 + 1.88(15 - 0)]$$

$$= 52.99 \text{ kJ/kg of dry air}$$

Total heat load = $m_a (h_2 - h_1)$

$$= 0.7(52.99 - 88.94) = -25 \text{ kW}$$

24. Ans: (a)

Sol:

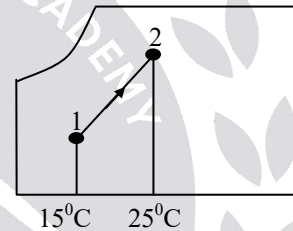

$P_{\text{total}} = 90 \text{ kPa}$, $T_{\text{sat}} = 15^\circ\text{C}$, $P_{\text{sat}} = 1.7057 \text{ kPa}$

$$\phi_1 = \frac{P_{V_1}}{P_{\text{sat}_1}} = 0.75$$

$$P_{V_1} = 1.278 \text{ kPa}$$

$$\omega_1 = 0.622 \times \frac{P_{V_1}}{P_{\text{atm}} - P_{V_1}} = 0.622 \times \frac{1.278}{90 - 1.278}$$

$$= 0.0089 \frac{\text{kg of vapour}}{\text{kg of dry air}}$$

$T_{\text{sat}} = 25^\circ\text{C}$, $P_{\text{sat}} = 3.1698 \text{ kPa}$, $\phi = 0.75$

$$\phi = \frac{P_{V_2}}{P_{\text{sat}_2}} \Rightarrow P_{V_2} = 2.377 \text{ kPa}$$

$$\omega_2 = 0.622 \times \frac{P_{V_2}}{P_{\text{atm}} - P_{V_2}}$$

$$= 0.622 \times \frac{2.377}{90 - 2.377} = 0.0168 \frac{\text{kg of Vap}}{\text{kg of dry air}}$$



Mass of vapour added ,

$$\begin{aligned} \dot{m}_v &= \dot{m}_a (\omega_2 - \omega_1) \\ &= 4(0.0168 - 0.0089) \\ &= 0.03 \text{ kg of vapor/sec} \end{aligned}$$

25.

Sol: $P_{\text{sat}} = 3.166 \text{ kPa}$,

$$T_{\text{sat}} = 25^\circ\text{C} = 298 \text{ K}$$

$$\phi = 0.74 = \frac{P_v}{P_{\text{sat}}} = \frac{P_v}{3.166}$$

$$P_v = 0.74 \times 3.166 = 2.34 \text{ kPa,}$$

At 2.34 kPa , $T_{\text{sat}} = 20^\circ\text{C} = 293 \text{ K} = \text{DPT}$

Corresponding to saturation temperature whatever the saturation pressure, the water vapor starts condensing.

$$dT = 298 - 293 = 5 \text{ K}$$

$$6.5 \text{ K drops in temperature} = 1000 \text{ m}$$

$$\begin{aligned} 5 \text{ K drop temperature} &= \frac{5}{6.5} \times 1000 \\ &= 769 \text{ m} \end{aligned}$$

26.

Sol: At $T_1 = 20^\circ\text{C}$

$$P_{\text{sat}} = 2.337 \text{ kPa, } \phi_1 = 0.65$$

$$\begin{aligned} \phi_1 &= \frac{P_{V_1}}{P_{\text{sat}}} \Rightarrow P_{V_1} = \phi_1 P_{\text{sat}} = 0.65 \times 2.337 \\ &= 1.52 \text{ kPa} \end{aligned}$$

$$\begin{aligned} \omega_1 &= 0.622 \frac{P_{V_1}}{P_{\text{atm}} - P_{V_1}} \\ &= 0.622 \times \frac{1.524}{100 - 1.524} \end{aligned}$$

$$= 0.0096 \frac{\text{kg of vapour}}{\text{kg of dry air}}$$

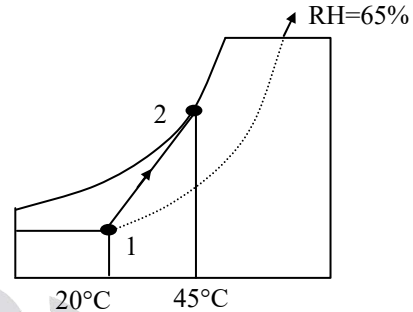

$$T_2 = 45^\circ\text{C, } \phi_2 = 100\%$$

$$P_{V_2} = P_{\text{sat}} = 9.557 \text{ kPa}$$

$$\begin{aligned} \omega_2 &= 0.622 \times \frac{9.557}{100 - 9.557} \\ &= 0.066 \frac{\text{kg of vapour}}{\text{kg of dry air}} \end{aligned}$$

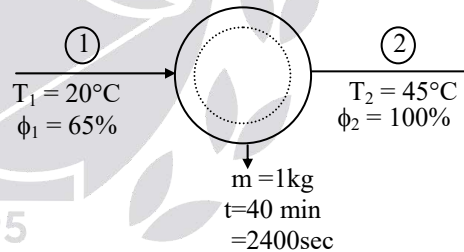

Mass of water absorbed by air

$$\dot{m}_w = \dot{m}_a (\omega_2 - \omega_1)$$

$$\frac{1}{2400} = \dot{m}_a (0.066 - 0.0096)$$

$$= 0.0073 \text{ kg/sec}$$

$$\dot{m}_a = 0.0073 \times 3600 = 26.6 \text{ kg/hr}$$



27. Ans: 0.02

Sol: $m = m_a + m_{v_1}$

$$\frac{m}{m_a} = 1 + \frac{m_{v_1}}{m_a}$$

$$\frac{m}{m_a} = 1 + \omega_1$$

$$\frac{10.1}{m_a} = 1.01$$

$$\dot{m}_a = \frac{10.1}{1.01} = 10 \text{ kg/sec}$$

$$\dot{m}_{v_1} = \omega_1 \times m_a = 0.01 \times 10 = 0.1 \text{ kg/sec}$$

$$\dot{m}_{v_2} = 0.1 \text{ kg/sec}$$

Total mass of vapour after mixing

$$\begin{aligned} &= \dot{m}_v = \dot{m}_{v_1} + \dot{m}_{v_2} \\ &= 0.1 + 0.1 \\ &= 0.2 \text{ kg/sec} \end{aligned}$$

Specific humidity of mixture

$$\begin{aligned} \omega &= \frac{\dot{m}_v}{\dot{m}_a} = \frac{0.2 \text{ kg/sec}}{10 \text{ kg/sec}} \\ &= 0.02 \text{ kgvap/kgd.a} \end{aligned}$$

Chapter- 10
Rankine Cycle

01. Ans: (d)

Sol: Assertion is false and Reason is true

Steam rate or specific steam consumption

$$= \frac{1 \text{ kg}}{W_T - W_C \text{ kW sec}} = \frac{3600 \text{ kg}}{W_T - W_P \text{ kW.hr}}$$

For Carnot cycle as pump work is very high so specific steam consumption is very high.

For Carnot cycle the mean temperature heat addition is greater than Rankine cycle, so $\eta_C > \eta_R$

02. Ans: (d)

03. Ans: (d)

Sol: Process ABCDE is heat addition process in boiler.

04. Ans: (b)

Sol: The expansion process in turbine like 1-2 is carried out in modified Rankine cycle.

05. Ans: (c)

Sol: Due to reheating in Rankine cycle :

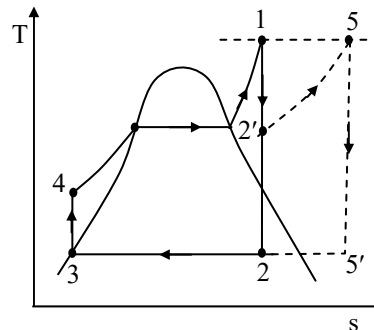



- (i) Work output of turbine increases as expansion is carried in two stages.

$$W(\text{without reheat}) = h_1 - h_2$$

$$W(\text{with reheat}) = (h_1 - h_2') + (h_5 - h_5')$$

- (ii) Turbine efficiency increases as mean temperature of heat addition increases.

(iii) Specific steam consumption = $\frac{3600}{W_{\text{net}}}$

As W_{net} increases so specific steam consumption decreases.

06. Ans: (b)

Sol:

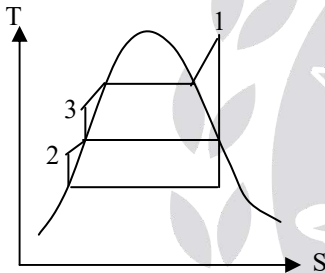

$$h_1 = 3514 \text{ kJ/kg}$$

$$W_{\text{HP}} = 3 \text{ kJ/kg}$$

$$h_2 = 613 \text{ kJ/kg,}$$

$$W_{\text{LP}} = 1 \text{ kJ/kg}$$

$$h_3 - h_2 = W_{\text{HP}}$$

$$h_3 - 613 = 3$$

$$h_3 = 616 \text{ kJ/kg}$$

$$Q_s = h_1 - h_3 = 3514 - 616 = 2898 \text{ kJ/kg}$$

07. Ans: (d)

Sol: $\eta = \frac{P_w}{\text{Power input}} = \frac{vdp}{\text{Power input}}$

$$0.75 = \frac{0.15(5000 - 200)}{P_i}$$

$$P_i = 16 \text{ kW}$$

08. Ans: 3.6

Sol: Specific steam consumption = $\frac{3600}{W_{\text{net}}}$

$$W_T = 3103 - 2100 - 3 = 1000 \text{ kJ/kg}$$

$$\text{Specific steam consumption} = \frac{3600}{1000}$$

$$= 3.6 \text{ kg/kW-hr}$$

09.

Sol: At $T_1 = 500^\circ\text{C}$ and 7 MPa

$$h_1 = 3410.3 \text{ kJ/kg}$$

$$s_1 = 6.7975 \text{ kJ/kgK}$$

At 10 kPa

$$h_3 = h_{f_3} = 191.83 \text{ kJ/kg}$$

$$s_3 = s_{f_3} = 0.6493 \text{ kJ/kgK}$$

$$v_3 = v_{f_3} = 1.01 \times 10^{-3} \text{ m}^3/\text{kg}$$

$$s_{g_2} = 8.1502 \text{ kJ/kgK}$$

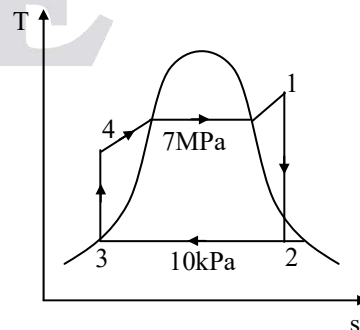



Process (1-2)

$$Q = 0, s = c$$

$$s_1 = s_2 = 6.7975 \text{ kJ/kg K} < 8.1502 \frac{\text{kJ}}{\text{kgK}}$$

So point 2 is in wet state

$$s_2 = s_{f2} + x_2 s_{fg2}$$

$$6.7975 = 0.6493 + x_2 (8.1502 - 0.6493)$$

$$x_2 = 0.82$$

$$h_2 = h_{f_2} + x_2 h_{fg_2}$$

$$= 191.83 + 0.82 \times 2392.8$$

$$= 2153.92 \text{ kJ/kg}$$

Process (3-4)

$$s_3 = s_4 = 0.6393 \text{ kJ/kgK}$$

$$W_p = h_4 - h_3 = V_{f_3} \times (P_{\text{boil}} - P_{\text{cond}})$$

$$= 1.01 \times 10^{-3} (7000 - 10)$$

$$= 7.05 \text{ kJ/kg}$$

$$h_4 = 7.05 + 191.83 = 198.88 \text{ kJ/kg}$$

$$W_T = h_1 - h_2 = 3410.3 - 2153.92$$

$$= 1256.4 \text{ kJ/kg}$$

Heat supplied, $Q_s = h_1 - h_4$

$$3410.3 - 198.88 = 3211.5 \text{ kJ/kg}$$

$$W_{\text{net}} = W_T - W_p = 1256.4 - 7.05$$

$$= 1249.35 \text{ kJ/kg}$$

$$\text{Work ratio} = \frac{W_{\text{net}}}{W_T} = \frac{1249.35}{1256.4} = 0.99$$

$$\eta_{\text{th}} = \frac{W_{\text{net}}}{Q_s} = \frac{1249.35}{3211.5} = 38.9\%$$

$$\text{Steam rate} = \frac{3600}{W_{\text{net}}} = 2.8816 \text{ kg/kW-hr}$$

$$\text{Heat rate} = \frac{3600}{\eta_{\text{th}}} = 9254 \text{ kJ/kW-hr}$$

$$\text{Power} = \dot{m}_s \times W_{\text{net}} = 30 \times 10^3$$

$$\dot{m}_s = \frac{30 \times 10^3}{1249.35} = 24.01 \text{ kg/sec}$$

Boiler capacity is mass flow rate of steam expressed in kg/hr

$$= 24.01 \times 3600 \text{ kg/hr}$$

$$= 86436 \text{ kg/hr}$$

$$\text{Condenser load} = \dot{m}_s (h_2 - h_3)$$

$$= 24.01 (2153.92 - 191.83)$$

$$= 47109.7 \text{ kW}$$

$(\Delta T)_w$ = rise in temperature of water

Heat gained by water = condenser load

$$\dot{m}_w \times C_{pw} \times (\Delta T)_w = 47109.7$$

$$(\Delta T)_w = \frac{47109.7}{2000 \times 4.186} = 5.63^\circ\text{C}$$

10.

Sol: State - 1

$$P_1 = 10 \text{ MPa}$$

$$T_1 = 500^\circ\text{C}$$

$$h_1 = 3373.7 \text{ kJ/kg}$$

$$s_1 = 6.5966 \text{ kJ/kgK}$$

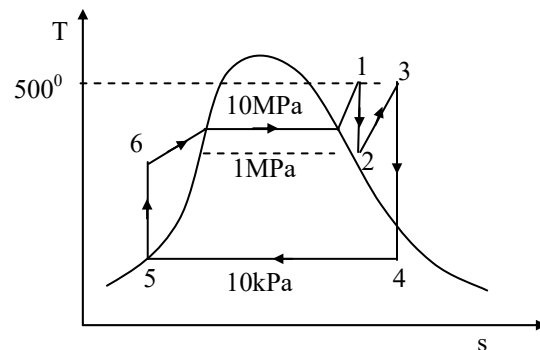



State – 2

$$P_2 = 1 \text{ MPa}$$

$$T_2 = ? \quad T_{\text{sat}} = 179.91^\circ\text{C}, \quad h_2 = ?$$

$$s_1 = 6.5966 \text{ kJ/kg} = s_2$$

$$s_2 = s_{g_2} + C_{P_{\text{Vapour}}} \times \ln\left(\frac{T_2}{T_{\text{sat}}}\right)$$

(As $s_2 > s_{g_2}$ it is in superheated state)

$$s_2 = 6.5966 \text{ kJ/kgK}$$

$$= 6.5865 + 2.1 \times \ln\left(\frac{T_2}{(273 + 179.91)}\right)$$

$$T_2 = 455.09 \text{ K}$$

$$h_2 = h_{g_2} + C_{P_{\text{vapour}}} \times (T_2 - T_{\text{sat}})$$

$$= 2778.1 + 2.1[455.09 - (273 + 179.91)]$$

$$= 2782.67 \text{ kJ/kg}$$

State – 3

$$P_3 = 1 \text{ MPa}$$

$$T_3 = 500^\circ\text{C}$$

$$h_3 = 3478.5 \text{ kJ/kg}$$

$$s_3 = 7.7622 \text{ kJ/kg K}$$

State – 4

$$P_4 = 10 \text{ kPa}$$

$$T_4 = 45.81^\circ\text{C}$$

$$h_4 = ?$$

$$s_4 = s_3 = 7.7622 \text{ kJ/kg K}$$

$$s_4 = s_{f_4} + x_4(s_{g_4} - s_{f_4})$$

$$= 0.6493 + x_4(8.1502 - 0.6493)$$

$$x_4 = 0.94 \rightarrow (\text{wet state})$$

$$h_4 = h_{f_4} + x_4(h_{g_4} - h_{f_4})$$

$$= 191.83 + 0.94(2584.6 - 191.83)$$

$$= 2441.03 \text{ kJ/kg}$$

State – 5

$$P_5 = 10 \text{ kPa}$$

$$h_5 = (h_f)_w = 191.83 \text{ kJ/kg}$$

$$s_5 = s_{f_5} = 0.6493 \text{ kJ/kg K}$$

$$v_5 = 0.0010 \text{ m}^3/\text{kg}$$

State – 6

$$P_6 = 1 \text{ MPa}$$

$$S_6 = 0.6493 \text{ kJ/kg.K}$$

$$W_p = v_{f_5}(P_6 - P_5)$$

$$= 0.0010 \times (10 \times 10^3 - 10) = 9.99 \text{ kJ/kg}$$

$$W_p = (h_6 - h_5)$$

$$h_6 = W_p + h_5$$

$$= 9.99 + 191.83 = 201.82 \text{ kJ/kg}$$

$$W_T = (h_1 - h_2) + (h_3 - h_4)$$

$$= (3373.7 - 2782.67) + (3478.5 - 2441.03)$$

$$= 1628.5 \text{ kJ/kg}$$

$$W_{\text{net}} = W_T - W_p = 1628.5 - 9.99$$

$$= 1618.51 \text{ kJ/kg}$$

$$\text{Work ratio} = \frac{W_{\text{net}}}{W_T} = \frac{1618.51}{1628.5} = 0.99$$

$$\text{Heat supplied } Q_s = (h_1 - h_6) + (h_3 - h_2)$$

$$= (3373.7 - 201.82) + (3478.5 - 2782.67)$$

$$= 3867.71 \text{ kJ/kg}$$

$$\eta_{\text{th}} = \frac{W_{\text{net}}}{Q_s} = \frac{1618.51}{3867.71} = 0.418 = 41.8\%$$

11.

Sol: State - 1: (super heated)

$$P_1 = 6 \text{ MPa}$$

$$T_1 = 450^\circ\text{C}$$

$$h_1 = 3301.8 \text{ kJ/kg}$$

$$s_1 = 6.7193 \text{ kJ/kgK}$$

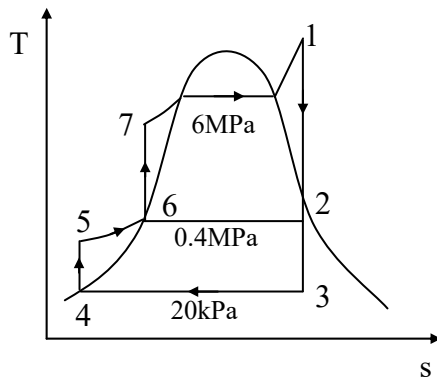

State - 2: (wet state)

$$P_2 = 0.4 \text{ MPa}$$

$$h_2 = ?, \quad T_2 = ?$$

$$s_2 = 6.7193 \text{ kJ/kg}$$

$$s_{g_2} = 6.8959 \text{ kJ/kg K}$$

As $s_2 < s_{g_2}$ this is in wet state

$$s_2 = s_{f_2} + x_2 (s_{g_2} - s_{f_2})$$

$$6.7193 = 1.7766 + x_2 (6.8959 - 1.7766)$$

$$x_2 = 0.96$$

$$h_2 = h_{f_2} + x_2 (h_{g_2} - h_{f_2})$$

$$= 604.74 + 0.96 (2738.6 - 604.74)$$

$$= 2653.24 \text{ kJ/kg}$$

State - 3: (wet state)

$$P_3 = 20 \text{ kPa}$$

$$h_3 = ?$$

$$s_2 = s_3 = 6.7193 \text{ kJ/kgK}$$

$$s_{g_3} = 7.9085 \text{ kJ/kg K}$$

$$6.7193 = 0.8320 + x_3 (7.9085 - 0.8320)$$

$$x_3 = 0.83$$

$$h_3 = h_{f_3} + x_3 (h_{g_3} - h_{f_3})$$

$$= 251.4 + 0.83 (2609.7 - 251.40)$$

$$= 2208.8 \text{ kJ/kg}$$

State - 4: (saturated)

$$P_4 = 20 \text{ kPa}$$

$$h_4 = h_{f_4} = 251.40 \text{ kJ/kg}$$

State - 5: (compressed)

$$P_5 = 0.4 \text{ MPa}$$

State - 6: (saturated)

$$P_6 = 0.4 \text{ MPa}$$

$$h_6 = h_{f_6} = 604.74 \text{ kJ/kg}$$

$$s_6 = 1.7766 \text{ kJ/kg.K}$$

State - 7: (compressed)

$$P_7 = 6 \text{ MPa}$$

High pressure pump work

$$W_{HP} = v_{f_6} (P_7 - P_6)$$

$$= 1.084 \times 10^{-3} (6 \times 10^3 - 0.4 \times 10^3)$$

$$= 6.0704 \text{ kJ/kg}$$

$$h_7 = h_6 + W_{HP}$$

$$= 604.74 + 6.0704 = 610.81 \text{ kJ/kg}$$

Low pressure pump work

$$W_{LP} = v_{f_4} (P_5 - P_4)$$

$$= 1.017 \times 10^{-3} (0.4 \times 10^3 - 20)$$

$$= 0.386 \text{ kJ/kg}$$

$$h_5 = h_4 + W_{LP}$$

$$= 251.40 + 0.386 = 251.786 \text{ kJ/kg}$$

The mass of steam m_1 extracted from turbine at 0.4 MPa

Energy balance:

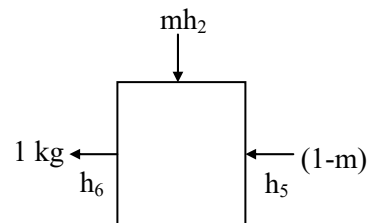



Energy in = Energy out

$$(1-m) h_5 + m h_2 = 1 \times h_6$$

$$\Rightarrow m (h_2 - h_5) = h_6 - h_5$$

$$m = \frac{h_6 - h_5}{h_2 - h_5}$$

$$= \frac{604.74 - 251.786}{2653.24 - 251.786} = 0.146 \text{ kg}$$

$$\begin{aligned} W_T &= (h_1 - h_2) + (1-m) (h_2 - h_3) \\ &= (3301.8 - 2653.24) + (1 - 0.146) \\ &\quad \times (2653.24 - 2208.8) \\ &= 1028.12 \text{ kJ/kg} \end{aligned}$$

$$\begin{aligned} W_P &= W_{HP} + W_{LP} \\ &= 6.0704 + 0.386 = 6.456 \text{ kJ/kg} \end{aligned}$$

$$\begin{aligned} W_{net} &= W_T - W_P = 1028.12 - 6.456 \\ &= 1021.66 \text{ kJ/kg} \end{aligned}$$

$$\begin{aligned} Q_s &= h_1 - h_7 \\ &= 3301.8 - 610.07 = 2691.73 \text{ kJ/kg} \end{aligned}$$

$$\eta_{th} = \frac{W_{net}}{Q_s} = \frac{1021.66}{2691.73} = 0.379 = 37.9\%$$

12. Ans: (a)

Sol: At 5 MPa,

$$T_{sat} = 263.9^\circ\text{C},$$

At 2 MPa,

$$T_{sat} = 212.38^\circ\text{C}$$

$$\eta_{Carnot} = \frac{263.9 - 212.38}{263.9 + 273} = 0.095$$

$$\text{Work done} = 0.095 \times 380 = 36.5 \text{ kW}$$

Note: Correct answer is option (a)

Chapter- 11
Gas Turbines

01.

Sol:

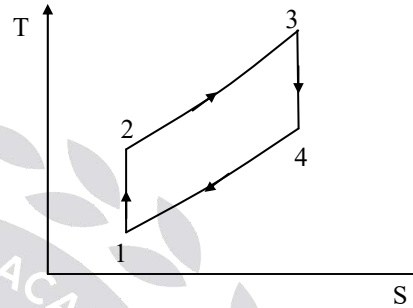

Given

$$T_1 = 300 \text{ K}$$

$$P_1 = 0.1 \text{ MPa}$$

$$\frac{P_2}{P_1} = 6.25 = \frac{P_3}{P_4}$$

$$T_3 = 800 + 273 = 1073 \text{ K}$$

$$\frac{T_2}{T_1} = \left(\frac{P_2}{P_1} \right)^{\frac{\gamma-1}{\gamma}} = (6.25)^{\frac{0.4}{1.4}} \quad \{\gamma = 1.4 \text{ for air}\}$$

$$T_2 = 506.4 \text{ K}$$

$$\frac{T_3}{T_4} = \left(\frac{P_3}{P_4} \right)^{\frac{0.4}{1.4}} = (6.25)^{\frac{0.4}{1.4}}$$

$$\frac{1073}{T_4} = (6.25)^{\frac{0.4}{1.4}}$$

$$T_4 = 635.6 \text{ K}$$

(a) Work done on the compressor

$$\begin{aligned} W_C &= m \times C_p \times (T_2 - T_1) \\ &= 1 \times 1.005 \times (506.4 - 300) \\ &= 207.432 \text{ kJ/kg} \end{aligned}$$



(b) Work done by Turbine

$$W_T = m \times C_p \times (T_3 - T_4)$$

$$= 1 \times 1.005 \times (1073 - 635.6)$$

$$= 439.587 \text{ kJ/kg}$$

(c) Heat supplied

$$Q_S = m C_p \times (T_3 - T_2)$$

$$= 1 \times 1.005 \times (1073 - 506.4)$$

$$Q_S = 569.433 \text{ kJ/kg}$$

(d) $\eta_{th} = \frac{W_T - W_C}{Q_S} = \frac{439.587 - 207.432}{569.433}$

$$= 40.77\%$$

02.

Sol:

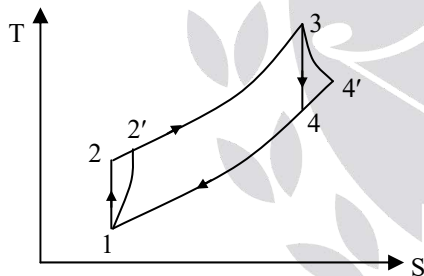

Caloric value (CV) = 42000 kJ/kg

$$\eta_T = 0.85, \quad \eta_c = 0.8$$

$$T_{\max} = T_3 = 875^\circ\text{C} = 1148\text{K}$$

$$P_1 = 1 \text{ atm}$$

$$T_1 = 300 \text{ K}$$

$$\frac{P_2}{P_1} = 4 = r_p$$

The temperature after isentropic compression

$$T_2 = T_1 (r_p)^{\frac{\gamma-1}{\gamma}}$$

$$= 300 \times 4^{\frac{1.4-1}{1.4}} = 446 \text{ K}$$

The isentropic efficiency of the compressor

$$\eta_c = \frac{W_{s=c}}{W_{\text{actual}}} = \frac{C_p (T_2 - T_1)}{C_p (T'_2 - T_1)}$$

$$\Rightarrow 0.8 = \frac{445.8 - 300}{T'_2 - 300}$$

$$\Rightarrow T'_2 = 482.5 \text{ K}$$

T'_2 = actual temperature at exit of compressor

Process 3-4: Q=0, S=C

$$\frac{T_3}{T_4} = \left(\frac{P_3}{P_4} \right)^{\frac{\gamma-1}{\gamma}}$$

$$T_4 = \frac{T_3}{(4)^{\frac{0.4}{1.4}}} = \frac{1148}{4^{\frac{0.4}{1.4}}}$$

$$T_4 = 773 \text{ K}$$

$$\eta_T = \frac{W_{\text{act}}}{W_{S=C}} = \frac{C_p (T_3 - T_{4'})}{C_p (T_3 - T_4)}$$

$$T_{4'} = 1148 - 0.85(1148 - 773)$$

$$T_{4'} = 829\text{K}$$

$$W_T = C_p (T_3 - T_{4'}) = 1.005(1148 - 829)$$

$$= 320.32 \text{ kJ/kg}$$

$$W_C = C_p (T'_2 - T_1) = 1.005(483 - 300) = 184 \text{ kJ/kg}$$

$$Q_S = C_p (T_3 - T'_2) = 1.005(1148 - 484)$$

$$= 668.325 \text{ kJ/kg}$$

$$W_{\text{net}} = W_T - W_C = 320.32 - 184$$

$$= 136.32 \text{ kJ/kg}$$

$$\text{Work ratio} = \frac{W_{\text{net}}}{W_T} = 0.428$$

$$\text{Back work ratio} = \frac{W_C}{W_T} = 0.571$$

$$\eta_{\text{th}} = \frac{W_{\text{net}}}{Q_S} = 20.5\%$$

$$\text{Heat rate} = \frac{3600}{\eta_{\text{th}}} = 17560.97 \frac{\text{kJ}}{\text{kW/hr}}$$

$$\text{Air rate} = \frac{3600}{W_{\text{net}}} = 26.22 \frac{\text{kg}}{\text{kWhr}}$$

$$T_{m1} = \frac{h_3 - h_{2'}}{s_3 - s_{2'}} = \frac{C_p(T_3 - T_{2'})}{C_p \left(\ln \frac{T_3}{T_{2'}} \right)} = 768 \text{ K}$$

$$T_{m2} = \frac{h_{4'} - h_1}{s_{4'} - s_1} = \frac{C_p(T_{4'} - T_1)}{C_p \left(\ln \frac{T_{4'}}{T_1} \right)} = 520.4 \text{ K}$$

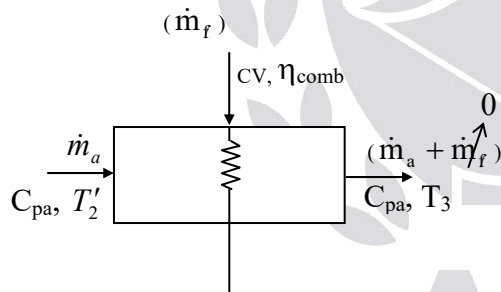

Energy balance:

$$\dot{m}_a C_{Pa} T_2' + \dot{m}_f (CV) \eta_{\text{comb}} = \dot{m}_a C_{Pa} T_3$$

$$\frac{\dot{m}_a}{\dot{m}_f} C_{Pa} T_2' + \dot{m}_f (CV) \eta_{\text{comb}} = \frac{\dot{m}_a}{\dot{m}_f} C_{Pa} T_3$$

$$(\text{AFR}) C_{Pa} T_2' + (CV) \eta_{\text{comb}} = (\text{AFR}) C_{Pa} T_3$$

$$\text{AFR} \times 1 \times 482.5 + 42000 \times 0.9 = \text{AFR} \times 1 \times 1148$$

$$\therefore \text{AFR} = 56.56:1$$

03.

Sol:

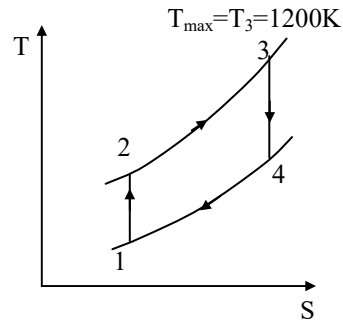

$$T_{\text{max}} = 1200 \text{ K}, \quad T_{\text{min}} = 300 \text{ K}$$

$$\text{At } (r_p)_{\text{opt}}, \quad T_2 = T_4 = \sqrt{T_1 T_3} = 600 \text{ K}$$

$$W_C = C_p (T_2 - T_1) = 1.005(600 - 300) = 301.5 \text{ kJ/kg}$$

$$W_T = C_p (T_3 - T_4) = 1.005(1200 - 600) = 603 \text{ kJ/kg}$$

$$\eta_{\text{th, (rp)opt}} = 1 - \sqrt{\frac{T_{\text{min}}}{T_{\text{max}}}} = 1 - \sqrt{\frac{300}{1200}} = 50\%$$

04. Ans: (a)

Sol:

- Due to Regeneration thermal efficiency increases as heat required in combustor is less.
- Reheating decreases thermal efficiency as mean temperature of heat rejection increases.
- When maximum temperature of the cycle is increased, thermal efficiency increases as mean temperature of heat addition increases.

05. Ans: (d)



06. Ans: (a)

Sol: During regeneration process, turbine work and compressor work remain unchanged and only heat supplied decreases so thermal efficiency increases.

07. Ans: (d)

Sol:

$$P_1 = 100 \text{ kPa,}$$

$$P_2 = 400 \text{ kPa}$$

$$T_1 = 298 \text{ K,}$$

$$T_3 = 1473 \text{ K}$$

$$r_p = \frac{400}{100} = 4$$

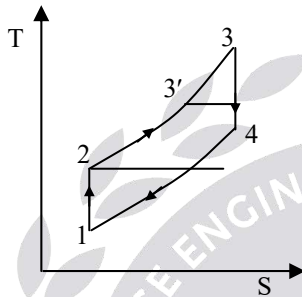

$$T_2 = T_1 (r_p)^{\frac{\gamma-1}{\gamma}} = 298 \times 4^{\frac{0.67}{1.67}} = 519.7 \text{ K}$$

$$T_4 = \frac{T_3}{(r_p)^{\frac{\gamma-1}{\gamma}}} = 844.61 \text{ K}$$

The maximum temperature up to which we can heat the compressed air is turbine exhaust temperature and this will happen when effectiveness of the heat exchanger must be unity.

i.e. $T_3' = T_4 = 844.61 \text{ K} = 573^\circ \text{C}$

08.

Sol: $T_1 = 300 \text{ K}$

$$r_p = 4$$

$$T_4 = 833 \text{ K}$$

$$\eta_T = 0.85$$

$$\eta_C = 0.83$$

$$\xi = 0.75$$

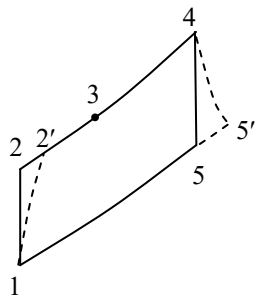

$$\frac{T_2}{T_1} = (r_p)^{\frac{\gamma-1}{\gamma}} \Rightarrow T_2 = 445.8 \text{ K} \quad \{\gamma = 1.4 \text{ for air}\}$$

$$\eta_C = 0.83 = \frac{T_2 - T_1}{T_2' - T_1} = \frac{445.8 - 300}{T_2' - 300}$$

$$T_2' = 475.66 \text{ K}$$

$$\frac{T_4}{T_5} = (r_p)^{\frac{\gamma-1}{\gamma}} = (4)^{\frac{0.4}{1.4}} \Rightarrow T_5 = 560.56 \text{ K}$$

$$\eta_T = 0.85 = \frac{T_4 - T_5'}{T_4 - T_5} = \frac{833 - T_5'}{833 - 560.56}$$

$$T_5' = 601.43 \text{ K}$$

$$\xi = \frac{Q_{act}}{Q_{max}} = \frac{T_3 - T_2'}{T_5' - T_2'} = \frac{T_3 - 475.66}{601.43 - 475.66}$$

$$\Rightarrow T_3 = 569.98 \text{ K}$$

$$\eta_{th} = \frac{W_T - W_C}{Q_S} = \frac{m c_p \times (T_4 - T_5') - m c_p \times (T_2' - T_1)}{m \times c_p \times (T_4 - T_3)}$$

$$= \frac{(833 - 601.43) - (475.66 - 300)}{833 - 569.98} = 21.26\%$$

09. Ans: (d)

Sol:

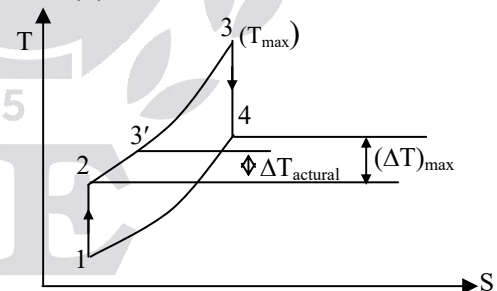

$$P_1 = 80 \text{ kPa,}$$

$$P_2 = 400 \text{ kPa,}$$

$$T_1 = 283 \text{ K}$$

$$T_3 = 1273 \text{ K}$$

$$r_p = \frac{400}{80} = 5$$

$$T_3' = 450 + 273 = 723 \text{ K}$$

$$T_4 = \frac{T_3}{(r_p)^{\frac{\gamma-1}{\gamma}}} = \frac{1273}{(5)^{\frac{0.4}{1.4}}} = 804 \text{ K}$$



Effectiveness of heat exchanger.

$$\epsilon = \frac{(\Delta T)_{\text{act}}}{(\Delta T)_{\text{max}}} = \frac{T_3' - T_2}{T_4 - T_2} \times 100 = 77\%$$

10. Ans: (c)

Sol: $T_{\text{min}} = T_1 = 20 + 273 = 293 \text{ K}$,

$T_{\text{max}} = T_4 = 900 + 273 = 1173 \text{ K}$

$\gamma = 1.3, \quad r_p = 6$

$$\begin{aligned} (\eta_B)_{\text{ideal regeneration}} &= 1 - \frac{T_{\text{min}}}{T_{\text{max}}} (r_p)^{\frac{\gamma-1}{\gamma}} \\ &= 1 - \left(\frac{293}{1173} \right) \times (6)^{\frac{1.3-1}{1.3}} \\ &= 0.62 \text{ or } 62\% \end{aligned}$$

11. Ans: (d)

Sol: Whenever we reheat, we reheat to the same temperature until unless mentioned in the problem. Whenever, we intercool to the same temperature, if there are infinitely large number of reheats and if there are infinitely large number of intercoolers then reversible adiabatic expansion becomes isothermal expansion and reversible adiabatic compression becomes isothermal compression and thermal efficiency of Brayton cycle becomes equal to Ericsson cycle.

$$\therefore (\eta_{\text{th}})_{\text{Braton}} = (\eta_{\text{th}})_{\text{Ericsson}}$$

Ericsson cycle is an ideal gas turbine cycle

Ideal $(\eta)_{\text{Ericsson}} = (\eta)_{\text{Carnot}}$

$$(\eta)_{\text{Carnot}} = 1 - \frac{T_{\text{min}}}{T_{\text{max}}} = 76\%$$

Chapter- 12 Refrigeration

01.

Sol: Refrigeration effect = 1 tonne
= 210 kJ/min
= 3.5 kW

Work input = 1.5 kW

$$\text{COP} = \frac{3.5}{1.5} = 2.33$$

02.

Sol: Maximum COP = Carnot COP

$$\begin{aligned} &= \frac{-30 + 273}{(273 + 32) - (273 - 30)} \\ &= \frac{243}{62} = 3.92 \end{aligned}$$

Actual COP = $0.75 \times 3.92 = 2.94$

$$2.94 = \frac{5}{W_{\text{input}}}$$

$\Rightarrow W_{\text{input}} = 1.7 \text{ kW}$

03.

Sol: Actual COP = $0.15 \times \text{Carnot's COP}$

$$\begin{aligned} &= 0.15 \times \frac{273 + 2}{(273 + 30) - (273 + 2)} \\ &= 1.473 \end{aligned}$$

$$\text{R.E} = \frac{8000}{24 \times 60 \times 60} \text{ kN} = 0.093 \text{ kW}$$

$$1.473 = \frac{0.093}{W_{\text{in}}}$$



$$\begin{aligned}
 W_{in} &= 0.063 \text{ kW} \\
 &= 0.063 \text{ kJ/s} \times 3600 \times 24 \text{ s} \\
 &= 5443.2 \text{ kJ} \\
 1 \text{ kW-h} &= 3600 \text{ kJ} \\
 5443.2 \text{ kJ} &= 1.5 \text{ kW-h}
 \end{aligned}$$

04. Ans: (a)

Sol:

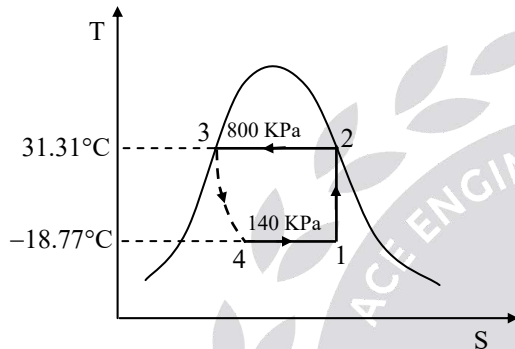

$$P_1 = 140 \text{ kPa}, P_2 = 800 \text{ kPa}$$

From steam table

$$h_2 = h_g = 267.29 \text{ kJ/kg}$$

$$h_3 = h_f = 95.49 \text{ kJ/kg}$$

$$Q_R = h_2 - h_3$$

$$= 267.29 - 95.49 = 171.82 \text{ kJ/kg}$$

$$(\text{COP})_{\text{HP}} = \frac{Q_R}{W} = \frac{T_2}{T_2 - T_1}$$

$$\frac{171.82}{W} = \frac{273 + 31.31}{(273 + 31.31) - (273 - 18.77)}$$

$$W = 28.54 \text{ kJ/kg}$$

05. Ans: (b)

Sol: For minimum required power input condition the COP has to be maximum and the maximum COP is the reversed Carnot cycle COP.

$$[(\text{COP})_{\text{Carnot}}]_{\text{Refrigerator}} = \frac{T_2}{T_1 - T_2} = \frac{Q_2}{W}$$

$$\Rightarrow \frac{268}{293 - 268} = \frac{0.35}{W}$$

$$\Rightarrow W_{\text{min}} = 33 \text{ W}$$

06. Ans: 12 kW

Sol:

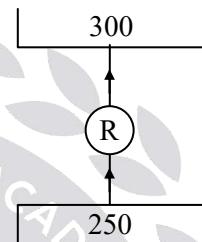

Total heat to be removed

$$\begin{aligned}
 &= 3600 \times 2 \times [27 - (-3)] + 3600 \times 230 + 3600 \times 20 \times 0.5 \\
 &= 1080000 \text{ kJ}
 \end{aligned}$$

$$\text{Rate of heat removed} = \frac{1080000}{10 \times 3600} = 30 \text{ kW}$$

$$\text{Actual cop} = 0.5 \times \frac{250}{300 - 250} = 2.5$$

$$2.5 = \frac{30}{\text{Power}}$$

Power input = 12 kW

07. Ans: (c)

Sol:

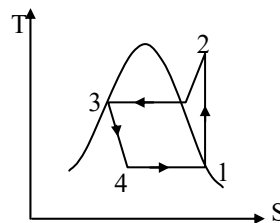

Ideal vapour compression means the compression starts from dry and saturated vapor line.



$$P_1 = 120 \text{ kPa}, \quad P_2 = 800 \text{ kPa}$$

$$h_1 = 236.97 \text{ kJ/kg}$$

$$h_3 = h_4 = 95.47 \text{ kJ/kg}$$

$$\text{Net refrigeration effect (NRE)} = 32 \text{ kW}$$

$$= \dot{m}_r (h_1 - h_4)$$

$$\dot{m}_r = 0.23 \text{ kg/sec}$$

08. Ans: (d)

Sol: $\dot{m}_r = 0.193 \text{ kg/sec}$

$$s_1 = s_2 = 0.93 \text{ kJ/kgK}$$

After compression the refrigerant is in superheated state with entropy = 0.93 at a pressure 1.2 MPa

$$h_1 = 251.88 \text{ kJ/kg}$$

$$h_2 = 278.27 \text{ kJ/kg}$$

$$h_3 = 117.73 \text{ kJ/kg}$$

$$\text{Heat supply} = \dot{m}_r (h_2 - h_3) = 30.98 \text{ kW}$$

09.

Sol:

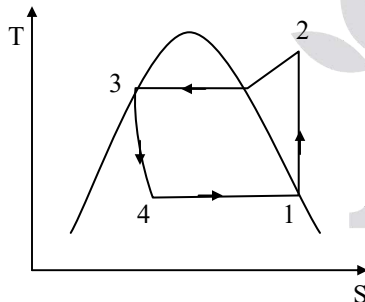

$$\text{Refrigeration effect} = 5 \text{ kW}$$

$$h_4 = 75 \text{ kJ/kg}, \quad h_1 = 183 \text{ kJ/kg},$$

$$h_2 = 210 \text{ kJ/kg}$$

(i) $\text{COP} = \frac{\text{Refrigeration effect}}{\text{work input}} = \frac{h_1 - h_4}{h_2 - h_1} = 4$

(ii) $\text{Cooling capacity} = \dot{m} \times (h_1 - h_4)$

$$5 = \dot{m} \times (183 - 75)$$

$$\dot{m} = 0.0463 \text{ kg/s}$$

Power input to the compressor

$$= \dot{m} \times (h_2 - h_1)$$

$$= 0.0463 \times (210 - 183)$$

$$= 1.25 \text{ kW}$$

(iii) Heat transfer at the condenser

$$= 0.0463 \times (h_2 - h_3)$$

$$= 0.0463 \times (210 - 75)$$

$$= 6.25 \text{ kW}$$

10. Ans: (b)

Sol: $h_3 = 107.32 \text{ kJ/kg} = h_4$ at 1 MPa

$$h_4 = h_{f_4} + x(h_{g_4} - h_{f_4})$$

$$107.32 = 22.49 + x(226.97 - 22.49)$$

Dry fraction of liquid, $x = 0.4$

Mass fraction of liquid = $1 - x = 0.6$

11. Ans: (d)

Sol:

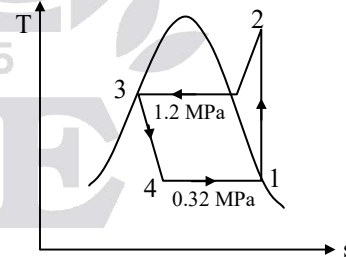

$$h_3 = 117.71 \text{ kJ/kg at 1.2 MPa}$$

$$h_1 = 251.8 \text{ kJ/kg at 0.32 MPa}$$

$$h_2 = 278.27 \text{ kJ/kg}$$

$$\text{COP} = \frac{h_1 - h_4}{h_2 - h_1} = \frac{251.8 - 117.71}{278.27 - 251.8} = 5.07$$



12. Ans: (d)

Sol:

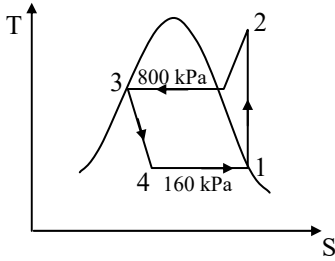

$$h_1 = 241 \text{ kJ/kg}$$

$$h_2 = 286.69 \text{ kJ/kg}$$

$$h_4 = h_3 = 95.47 \text{ kJ/kg}$$

$$\text{COP} = \frac{h_1 - h_4}{h_2 - h_1} = \frac{\text{NRE}}{W_c} = 3.2$$

13.

Sol:

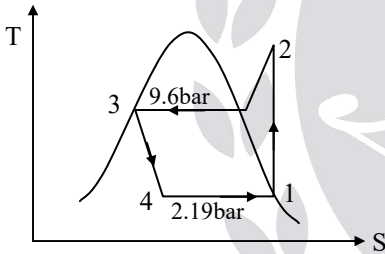

$$h_3 = h_4 = 64.6 \text{ kJ/kg}, \quad h_1 = 195.7 \text{ kJ/kg}$$

$$v_1 = 0.082 \text{ m}^3/\text{kg}$$

$$n = 1.13$$

$$\text{NRE (kW)} = 3.517 \times 15 = \dot{m}_r (h_1 - h_4)$$

$$\dot{m}_r = 0.402 \text{ Kg/sec}$$

$$W_c (\text{kJ/kg}) = \frac{n}{n-1} P_1 v_1 \left[\left(\frac{P_2}{P_1} \right)^{\frac{n-1}{n}} - 1 \right]$$

$$= \frac{1.13}{1.13-1} \times 219 \times 0.082 \left[\left(\frac{9.6}{2.19} \right)^{\frac{1.13-1}{1.13}} - 1 \right]$$

$$= 28.92 \text{ kJ/kg}$$

$$W_c (\text{kW}) = 0.402 \times 28.92 = 11.62 \text{ kW}$$

$$\text{COP} = \frac{\text{NRE}}{W_c} = \frac{15 \times 3.517}{11.62} = 4.54$$

14. Ans: (a)

Sol:

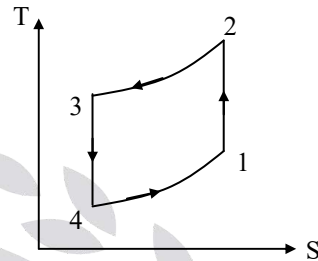

$$T_3 = 308 \text{ K}$$

$$T_4 = \frac{T_3}{(r_p)^{\frac{\gamma-1}{\gamma}}} = \frac{308}{\left(\frac{280}{80} \right)^{\frac{0.4}{1.4}}}$$

$$T_4 = -58^\circ\text{C}$$

15. Ans: (b)

Sol:

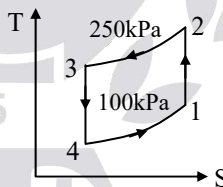

For Helium, $\gamma = 1.67$

$$\dot{m} = 0.2 \text{ kg/sec}, \quad T_1 = -10^\circ\text{C} = 263 \text{ K}$$

$$\text{Pressure ratio, } r_p = \frac{P_2}{P_1} = \frac{250}{100} = 2.5$$

$$T_2 = T_1 \times (r_p)^{\frac{\gamma-1}{\gamma}} = 263 \times (2.5)^{\frac{0.67}{1.67}} = 379.84 \text{ K}$$

$$T_4 = \frac{T_3}{(r_p)^{\frac{\gamma-1}{\gamma}}} = \frac{293}{(2.5)^{\frac{0.67}{1.67}}} = 202.87 \text{ K}$$



$$W_C = \dot{m}C_p(T_2 - T_1)$$

$$= \dot{m} \frac{\gamma \bar{R}}{M(\gamma - 1)}(T_2 - T_1)$$

$$= \frac{0.2 \times 1.67 \times 8.314}{4(1.67 - 1)}(379.84 - 263)$$

$$= 121 \text{ kW}$$

$$W_E = \dot{m} \frac{\gamma \bar{R}}{M(\gamma - 1)}(T_3 - T_4)$$

$$= \frac{0.2 \times 1.67 \times 8.314}{4 \times (1.67 - 1)} \times (293 - 202.87)$$

$$= 93.3 \text{ kW}$$

$$W_{\text{net}} = W_C - W_E$$

$$= 121 - 93.3 = 27.7 \text{ kW}$$

16.
Sol:

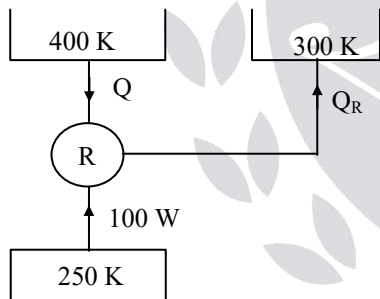

For minimum value of heat required

$$S_{\text{gen}} = 0$$

$$dS(\text{reservoir at } 400 \text{ K}) + dS(\text{reservoir at } 250\text{K}) + dS(\text{reservoir at } 300\text{K}) + dS(\text{working fluid}) = 0$$

$$\frac{-Q}{400} - \frac{100}{250} + \frac{Q_R}{300} + 0 = 0 \dots\dots\dots (i)$$

$$Q_R = 100 + Q \dots\dots\dots (ii)$$

Solve (i) and (ii)

$$Q = 80 \text{ W}$$

Chapter- 13
Thermodynamic Relations

01. Ans: (b)

Sol: Clayperon equation is given by

$$\left(\frac{dP}{dT}\right)_h = \frac{(h_g - h_f)}{T_s(v_g - v_f)}$$

$$\therefore (v_g - v_f) = \frac{dT_s}{dP} \frac{(h_g - h_f)}{T_s}$$

02. Ans: (a)

Sol: Joule Thomson coefficient is

$$\mu_j = \left(\frac{dT}{dP}\right)_h$$

It is the constant enthalpy line in temperature pressure curve of real gases.

03. Ans: (c)

Sol:

$$(a) (c_p - c_v) = -T \left(\frac{\partial V}{\partial T}\right)_P^2 \left(\frac{\partial P}{\partial V}\right)_T$$

$$\therefore \left(\frac{\partial P}{\partial V}\right)_T \text{ is always negative}$$

$$\therefore c_p - c_v > 0$$

Hence, c_p is always greater than c_v .

(b) For an ideal gas

$$Pv = RT$$

$$\left(\frac{dP}{dv}\right)_T v + P = 0$$



$$\left(\frac{dP}{dv}\right)_T = -\frac{P}{V} \text{ -----(1)}$$

$$\left(\frac{dv}{dT}\right)_P = \left(\frac{R}{P}\right) = \left(\frac{v}{T}\right) \text{ -----(2)}$$

From (1) and (2)

$$\therefore c_p - c_v = -T \times \frac{v^2}{T^2} \left(-\frac{P}{v}\right) = \frac{Pv}{T} = R$$

$$\therefore c_p - c_v = R$$

(c) $\left(\frac{\partial P}{\partial v}\right)_T$ is always negative.

$\left(\frac{\partial v}{\partial P}\right)_P^2$ is always positive

(d) For water (incompressible fluid)

$$\therefore c_p \approx c_v$$

04. Ans: (a)

Sol: Gibb's energy 'G' is given by

$$G = H - TS$$

05. Ans: (c)

06. Ans: (c)

Sol: Helmholtz function is given by

$$H = U - TS$$

07. Ans: (b)

Sol: Joule Thomson coefficient is

$$\mu_j = \left(\frac{\partial T}{\partial P}\right)_h = \text{slop of constant}$$

Enthalpy line in on T-P diagram

08. Ans: (b)

09. Ans: (d)

10. Ans: (b)

Sol: Clapeyron's equation for dry saturated steam is given by

$$(v_g - v_f) = \left(\frac{dT_s}{dP}\right)_h \frac{(h_g - h_f)}{T_s}$$

11. Ans: (c)

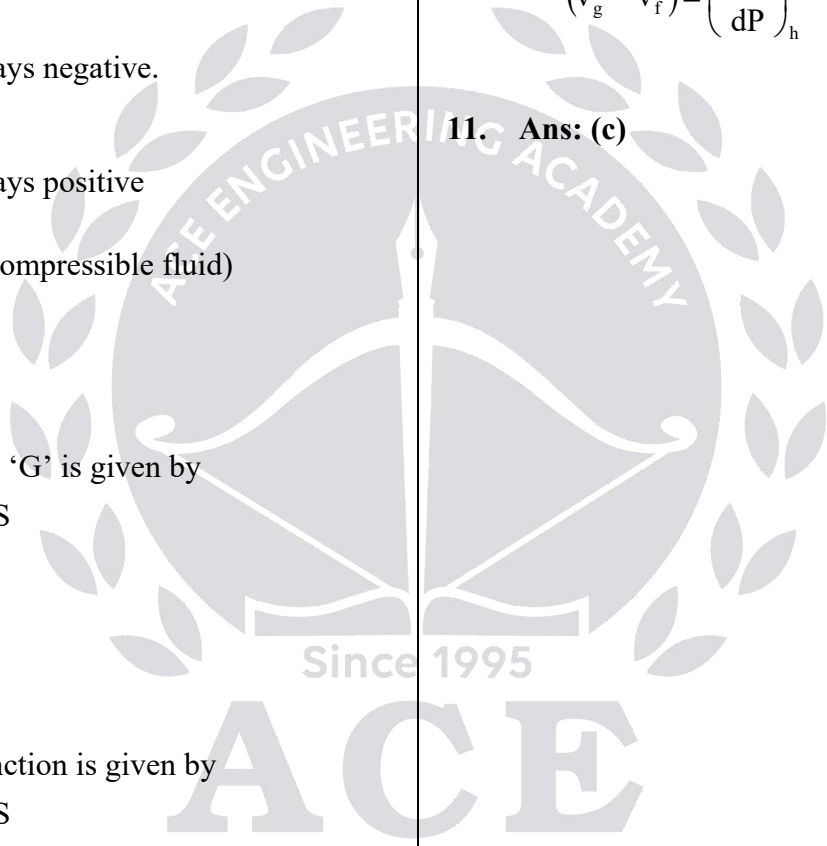



Chapter- 14
Reciprocating Air Compressors

01. Ans: (b)

Sol: $n = 2$, $P_s = 1.5$ bar, $P_d = 54$ bar

$$\begin{aligned} \text{Intercooler pressure, } P_i &= \sqrt{P_s P_d} \\ &= \sqrt{54 \times 1.5} \end{aligned}$$

$$\Rightarrow P_i = 9 \text{ bar}$$

02. Ans: (a)

03. Ans: (a)

$$\text{Sol: } \eta_v = 1 - C \left[\left(\frac{P_d}{P_s} \right)^{\frac{1}{n}} - 1 \right]$$

If clearance (C) is large volumetric efficiency (η_v) decreases hence volume flow rate decreases.

04. Ans: (c)

Sol: Mass of air in clearance volume has no effect on work done per kg of air.

05. Ans: (d)

Sol: Volumetric efficiency is given by

$$\eta_v = 1 - C \left[\left(\frac{P_2}{P_1} \right)^{\frac{1}{n}} - 1 \right]$$

where,

C = clearance ratio,

P_2 = delivery pressure,

P_1 = suction pressure

n = index of expansion

06. Ans: (c)

$$\text{Sol: } \eta_v = 1 - C \left[\left(\frac{P_2}{P_1} \right)^{\frac{1}{n}} - 1 \right]$$

where,

C = clearance ratio,

P_2 = delivery pressure,

P_1 = suction pressure

07. Ans: (d)

Sol: Total work of 3-stages is given by

$$W = \frac{3n}{(n-1)} P_1 V_1 \left[\left(\frac{P_2}{P_1} \right)^{\frac{n-1}{3n}} - 1 \right]$$

08. Ans: (a)

$$\text{Sol: } \eta_{Vol} = 1 + C - C \left(\frac{P_2}{P_1} \right)^{\frac{1}{n}} ; P_1 V_1^n = P_2 V_2^n$$

$$\eta_{Vol} = 1 + C - C \left(\frac{V_1}{V_2} \right) ; \left(\frac{V_1}{V_2} \right)^n = \frac{P_2}{P_1}$$

$$\eta_{Vol} = 1 + 0.05 - 0.05 \left(\frac{0.04}{0.02} \right) = 0.95 \text{ or } 95 \%$$



09. Ans: (b)

Sol: Advantages of multi-stage compression are

- Improved overall volumetric efficiency. If all compression were done in one cylinder the gas in the clearance volume would expand to a large volume before the new intake could begin. This results in a very low volumetric efficiency. By cooling the gas between the stages a much higher efficiency can be obtained.
- A reduction in work required per stroke, and therefore the total driving power.
- Size and strength of cylinders can be adjusted to suit volume and pressure of gas.
- Multi-cylinders give more uniform torque and better mechanical balance thus needing smaller flywheel.

10. Ans: (d)

$$\text{Sol: } \eta_v = 1 - C \left[\left(\frac{P_2}{P_1} \right)^{\frac{1}{n}} - 1 \right]$$

where, C = clearance ratio,

$$\frac{P_2}{P_1} = \text{pressure ratio}$$

We can observe from the above expression

that as C and $\frac{P_2}{P_1}$ increases η_v decreases.

11. Ans: (a)

Sol:

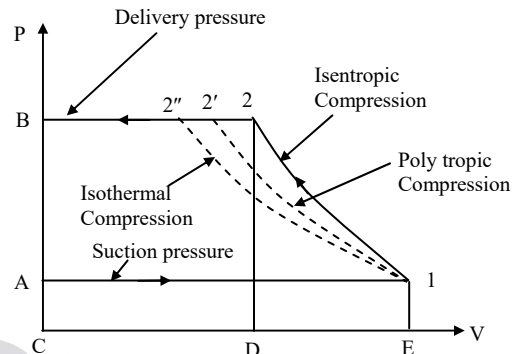

P-V representation of cycle in a reciprocating compressor

From the P.V. diagram we can see that work done is minimum when the compression process is isothermal.

12. Ans: (b)

13. Ans: (d)

Sol: Cooling of reciprocating compressor

1. increases volumetric efficiency
2. decreases work input

14. Ans: 3

$$\text{Sol: } \frac{T_2}{T_1} = \left(\frac{P_2}{P_1} \right)^{\frac{n-1}{n}}$$

$$\frac{423}{300} = \left(\frac{P_2}{1} \right)^{\frac{1.25-1}{1.25}}$$

$$P_2 = 5.57 \text{ bar}$$

For optimum intercooling pressure ratios are same



$$\frac{P_2}{P_1} = \frac{P_3}{P_2} = \frac{P_4}{P_3} = \frac{P_{n+1}}{P_n}$$

$$\left(\frac{P_2}{P_1}\right)^n = \frac{180}{1}$$

$$(5.57)^n = 180$$

$$\Rightarrow n \approx 3.023$$

$$\Rightarrow n = 3 \text{ stages.}$$

15.

Sol:

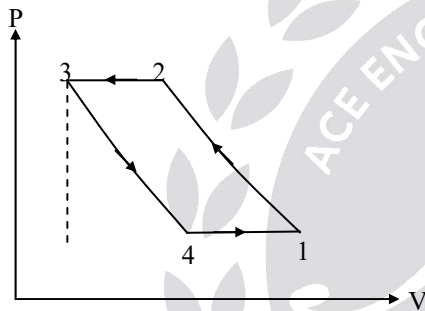

$$\text{Swept volume, } V_S = V_1 - V_3 = \frac{\pi}{4} \times D^2 \times L$$

$$= \frac{\pi}{4} \times 0.2^2 \times 0.3 = 9.42 \times 10^{-3} \text{ m}^3$$

$$\text{Clearance volume} = V_3 = 0.05 \times (V_1 - V_3)$$

$$= 4.71 \times 10^{-4} \text{ m}^3$$

$$V_1 = V_S + V_3 = 9.89 \times 10^{-3} \text{ m}^3$$

$$\frac{V_4}{V_3} = \left(\frac{P_3}{P_4}\right)^{\frac{1}{n}} = \left(\frac{550}{97}\right)^{\frac{1}{1.3}}$$

$$V_4 = 1.79 \times 10^{-3}$$

$$\text{Effective swept volume} = V_1 - V_4$$

$$= 8.1 \times 10^{-3} \text{ m}^3$$

$$\frac{P_a V_a}{T_a} = \frac{P_1 (V_1 - V_4)}{T_1}$$

$$= \frac{101.325 \times V_a}{288} = \frac{97 \times 8.1 \times 10^{-3}}{293}$$

(i) $V_a = 7.622 \times 10^{-3} \text{ m}^3/\text{cycle}$

$$V_a = 7.622 \times 10^{-3} \times 500 = 3.81 \text{ m}^3/\text{min}$$

(ii) Power required

$$= \frac{n}{n-1} P_1 (V_1 - V_4) \left[\left(\frac{P_2}{P_1}\right)^{\frac{n-1}{n}} - 1 \right]$$

$$= \frac{1.3}{1.3-1} \times 97 \times 8.1 \times 10^{-3} \times \left[\left(\frac{550}{97}\right)^{\frac{1.3-1}{1.3}} - 1 \right]$$

$$= 1.676 \text{ kJ/cycle}$$

$$= 1.676 \times \frac{500}{60} = 13.97 \text{ kW}$$

(iii) $\eta_v = 1 + C - C \left(\frac{P_2}{P_1}\right)^{\frac{1}{n}}$

$$= 1 + 0.05 - 0.05 \times \left(\frac{550}{97}\right)^{\frac{1}{1.3}}$$

$$= 86\%$$